

**LOS ANGELES COUNTY  
DEPARTMENT OF PUBLIC WORKS**

# Construction Site Best Management Practices (BMPs) Manual

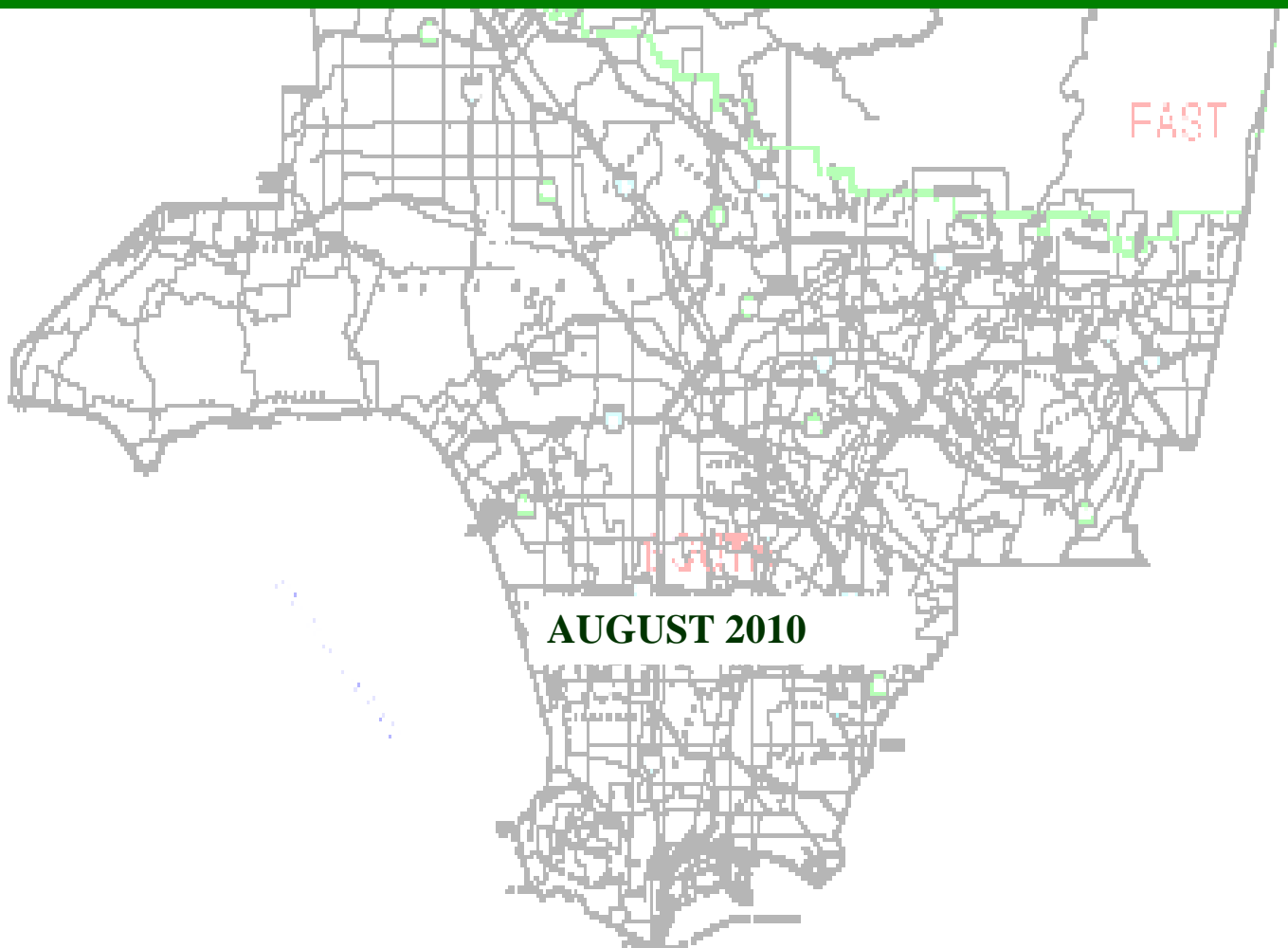

## **Construction Site Best Management Practices (BMP) Manual**

**Prepared By:**

Los Angeles County Department of Public Works  
Construction Division  
Environmental Compliance Unit  
Oscar R. Enriquez – Section Head

**Technical Review:**

John Gleason  
Chris Jones  
Ernie Mansfield

**References:**

Los Angeles County Department of Public Works,  
Construction Site Best Management Practices (BMPs) Manual, September 2007.

State Water Resources Control Board (SWRCB) Order No. 2009-0009-DWQ, National Pollutant Discharge Elimination System (NPDES) General Permit No. CAS000002, Waste Discharge Requirements (WDRs) for Discharges of Storm Water Runoff Associated with Construction and Land Disturbance Activities, September 2, 2009.

Regional Water Quality Control Board (RWQCB), Los Angeles Region, Order No. 01-182; NPDES Permit No. CAS004001 Municipal Storm Water and Urban Runoff Discharges within the County of Los Angeles, and Incorporated Cities Therein, December 13, 2001.

State of California Department of Transportation,  
Storm Water Quality Handbooks, Construction Site Best Management Practices (BMPs) Manual, March 2003.

California Stormwater Quality Association,  
Stormwater Best Management Practice Handbook, Construction, January 2003.

## Table of Contents

Section 1 Introduction	
1.1 Introduction.....	1-1
1.2 Organization of this Manual.....	1-2
1.3 Regulations and Permits.....	1-3
Section 2 Selecting and Implementing BMPs	
2.1 Minimum BMP Requirements.....	2-1
2.2 BMP Inspections and Checklist.....	2-7
2.3 BMP Non-Compliance and Enforcement Actions.....	2-7
Section 3 Temporary Soil Stabilization BMPs	
3.1 Temporary Soil Stabilization.....	3-1
3.2 Temporary Flow Conveyance.....	3-1
Section 4 Temporary Sediment Control BMPs.....	4-1
Section 5 Wind Erosion Control BMPs.....	5-1
Section 6 Tracking Control BMPs.....	6-1
Section 7 Non-Storm Water Management BMPs	
7.1 Construction Dewatering.....	7-1
7.2 Accumulated Precipitation.....	7-2
Section 8 Waste Management and Material Pollution Control BMPs	
8.1 Material Pollution Control BMPs.....	8-1
8.2 Waste Management BMPs.....	8-1
<b>Tables</b>	
1-1 Water Quality Protection Requirements.....	1-1
2-1 Construction Site BMPs.....	2-1
2-2 Storm Water Pollution Controls for Construction Activities.....	2-4
3-1 Temporary Soil Stabilization BMPs.....	3-1
4-1 Temporary Sediment Control BMPs.....	4-1
5-1 Wind Erosion Control BMPs.....	5-1

## Tables (continued)

6-1	Tracking Control BMPs .....	6-1
7-1	Non-Stormwater Management BMPs .....	7-1
8-1	Waste Management and Material Pollution Control BMPs.....	8-1

## Appendices

Appendix A: Abbreviations, Acronyms, Definitions of Terms

Appendix B: BMP Checklist

Appendix C: Notice of BMP Noncompliance Form

# SECTION 1

## INTRODUCTION

### 1.1 Introduction

The Construction Site Best Management Practices (BMP) Manual (BMP Manual) has been prepared by the Los Angeles County Department of Public Works (LACDPW) Construction Division to assist Contractors in the process of selection and implementation of construction site BMPs. This BMP Manual includes the LACDPW requirements for the implementation of construction site BMPs. As site conditions change or as deemed necessary, LACDPW may impose additional construction site BMPs for contractor activities. Additional BMPs may be included in the project's contract Special Provisions or may be required by the LACDPW Engineer (Engineer).

LACDPW has developed a program to control runoff from construction sites. The program requires Contractors to implement an effective combination of BMPs to protect water quality as identified in Table 1-1.

<b>Table 1-1</b>		
<b>Water Quality Protection Requirements</b>		
<b>Category</b>	<b>Requirements</b>	<b>BMP Section of Manual</b>
Soil Stabilization	Erosion from disturbed soil and concentrated flows shall be prevented by implementing appropriate BMPs, such as limiting grading and excavation during the wet season, diverting run-on, controlling runoff, slowing and spreading flows, breaking up disturbed areas with linear barriers and covering erosion susceptible areas.	Section 3
Sediment Control	Sediment shall not be discharged offsite, to the storm drain system or receiving waters. Sediments generated on the project shall be retained by implementing appropriate BMPs.	Section 4
Wind Erosion Control	Prevent wind erosion and dust by applying water or other dust palliatives or by covering as necessary.	Section 5
Tracking Control	Prevent or reduce tracking of sediment and prevent sediment from discharging to paved surfaces, offsite or entering storm drains or watercourses.	Section 6
Non-Storm Water	Non-storm water shall be retained on the construction site and shall be prevented from discharging to the	Section 7

Management	ground, offsite, or entering storm drains or watercourses. BMPs will be implemented to prevent non-storm water discharges.	
Waste Management & Material Pollution Control	Construction-related materials and waste shall be protected from contact with precipitation and run-on and runoff. Spills, leaks or residues shall be cleaned up immediately and all materials and waste shall be prevented from coming in contact with water or from being discharged to the ground, or discharged from the site or to the storm drain system.	Section 8

## 1.2 Organization of this BMP Manual

The organization of this BMP Manual is as follows:

- Section 1: Introduction – identifies the purpose and use of this BMP Manual, including a brief discussion of the regulatory framework and permits associated with the LACDPW storm water pollution prevention program.
- Section 2: Selecting and Implementing BMPs – provides the process for the selection and implementation of construction site BMPs.
- Section 3: Temporary Soil Stabilization – provides a list, appropriate application, limitations, standards and specifications, and inspection and maintenance of Temporary Soil Stabilization BMPs and Concentrated Flow Conveyance BMPs.
- Section 4: Temporary Sediment Control – provides a list, appropriate application, limitations, standards and specifications, and inspection and maintenance of Temporary Sediment Control BMPs.
- Section 5: Wind Erosion Control – provides a list, appropriate application, limitations, standards and specifications, and inspection and maintenance of Wind Erosion Control BMPs.
- Section 6: Tracking Control – provides a list, appropriate application, limitations, standards and specifications, and inspection and maintenance of Tracking Control BMPs.
- Section 7: Non-Storm Water Management – provides a list, appropriate application, limitations, standards and specifications, and inspection and maintenance of Non-Storm Water Management BMPs.
- Section 8: Waste Management and Material Pollution Control – provides a list, appropriate application, limitations, standards and specifications, and inspection and maintenance of Waste Management and Material Pollution Control BMPs.

- Appendix A provides a list and definitions of frequently used abbreviations, acronyms, and terms used in this BMP Manual.
- Appendix B has the LACDPW BMP Checklist with instructions.
- Appendix C has the LACDPW Notice of BMP Noncompliance form with instructions.

The Contractor shall know and fully comply with the applicable provisions of the contract Special Provisions, Construction Site BMP Manual and SWPPP Preparation Manual (if a SWPPP is required by contract Special Provisions), Permits, and Federal, State, and local regulations that govern the Contractor's operations and storm water discharges from the construction site.

This BMP Manual refers to the Engineer repeatedly. The Engineer is the LACDPW authorized representative on site (Engineer, Inspector, or LACDPW consultant).

### **1.3 Regulations and Permits**

In 1972, the Federal Water Pollution Control Act (also referred to as the Clean Water Act) (CWA) was amended to provide that the discharge of pollutants to waters of the United States from any point source is unlawful unless the discharge is in compliance with an NPDES permit. In 1987, the CWA was amended to establish a framework for regulating municipal and industrial storm water discharges under the NPDES Program. In 1990, the U.S. Environmental Protection Agency (USEPA) published final regulations that establish storm water permit application requirements for specified categories of industries. In 2003, the Phase II regulations became effective for small construction sites. The regulations provide that discharges of storm water to waters of the United States from construction projects that encompass one acre or more of soil disturbance are effectively prohibited unless the discharge is in compliance with an NPDES Permit.

The Regional Water Quality Control Board (RWQCB) regulates the discharge of storm water from municipalities and activities within their jurisdiction including construction. Part of the RWQCB Los Angeles Region regulations requires the County to have adequate enforcement capabilities for controlling storm water runoff. Los Angeles County Code Chapter 12.80.630 Storm Water and Pollution Runoff Control fulfills the requirement of the RWQCB for enforceable regulations.

The State Water Resources Control Board (SWRCB) issued the Small Municipal Separate Storm Sewer System (MS4) Permit (Small MS4 Permit) effective August 8, 2003 which will impact the County's unincorporated areas in the Antelope Valley. LACDPW requires the Antelope Valley portions of Los Angeles County to comply with the same requirements for Construction Site Storm Water Runoff Control as the rest of the County.

#### **1.3.1 General Permit**

The SWRCB has elected to adopt one statewide General Permit that will apply to all storm water discharges associated with construction activity.

In 2009, the SWRCB re-issued *National Pollutant Discharge Elimination System (NPDES) Permit No. CAS000002 under Order No. 2009-0009-DWQ, Waste Discharge Requirements for Discharges of Storm Water Runoff Associated with Construction and Land Disturbance Activities* (Construction General Permit) that requires all dischargers where construction activities disturb one or more acres to comply with the Construction General Permit and develop and implement a Storm Water Pollution Prevention Plan (SWPPP). For construction sites that disturb one or more acres, refer to the LACDPW “Storm Water Pollution Prevention Plan (SWPPP) Preparation Manual.”

### **1.3.2 Municipal Permit**

On December 13, 2001, the RWQCB, Los Angeles Region, adopted Order No. 01-182, NPDES Permit No. CAS004001, Waste Discharge Requirements for Municipal Storm Water and Urban Runoff Discharges within the County of Los Angeles, and Incorporated Cities Therein (MS4 Permit). This Permit was issued to the Los Angeles County Flood Control District, the County of Los Angeles, and 84 cities within the county; and requires the preparation and implementation of a storm water pollution prevention program to control runoff from construction sites within its jurisdiction. The MS4 Permit jurisdiction includes all areas of Los Angeles County except the northern (Antelope Valley) area. This BMP Manual is part of the LACDPW program to control runoff from all construction sites within Los Angeles County including the Antelope Valley.

### **1.3.3 Los Angeles County Code**

The Contractor is subject to enforcement action by Chapter 12.80 of the Los Angeles County Code (12.80.630) that states, *“Any person, firm, corporation, municipality or district or any officer or agent of any firm corporation, municipality or district violating any provision of this chapter shall be guilty of a misdemeanor. Such violation shall be punishable by a fine of not more than \$1,000 or by imprisonment in the county jail for a period not to exceed six months, or by both fine and imprisonment. Each day during any portion of which such violation is committed, continued or permitted shall constitute a separate offense and shall be punishable as such (Ord. 98-0021§1(part), 1998).”* LACDPW applies this code to all their construction sites.



## SECTION 2

### SELECTING AND IMPLEMENTING BMPs

This Section provides instructions to assist Contractors in the selection and implementation of construction site BMPs. The requirements in this BMP Manual reflect the LACDPW minimum requirements. LACDPW may impose additional construction site BMPs as necessary to adequately protect water quality and comply with storm water pollution prevention regulations. Additional BMPs may be included in the project's contract Special Provisions or required in the field by the Engineer.

Construction site BMPs are required to be implemented on a year-round basis during construction activities, including during any temporary suspension of work.

#### 2.1 Minimum BMP Requirements

Table 2-1 lists the Construction Site BMPs approved for use on LACDPW construction sites. The minimum BMPs identified on Table 2-1 shall be implemented on all LACDPW construction sites.

<b>Table 2-1 Construction Site BMPs<sup>(1)</sup></b>		
<b>ID</b>	<b>BMP Name</b>	<b>Minimum Requirement</b>
<b>Temporary Soil Stabilization</b>		
SS-1	Scheduling	<b>X</b>
SS-2	Preservation of Existing Vegetation	<b>X</b>
SS-3	Hydraulic Mulch <sup>(2)</sup>	
SS-4	Hydroseeding <sup>(2)</sup>	
SS-5	Soil Binders <sup>(2)</sup>	
SS-6	Straw Mulch <sup>(2)</sup>	
SS-7	Geotextiles, Plastic Covers, & Erosion Control Blankets/Mats <sup>(2)</sup>	
SS-8	Wood Mulching <sup>(2)</sup>	
SS-9	Earth Dikes/Drainage Swales & Lined Ditches	
SS-10	Outlet Protection/Velocity Dissipation Devices	
SS-11	Slope Drains	
SS-12	Streambank Stabilization	
<b>Temporary Sediment Control</b>		
SC-1	Silt Fence	<b>X<sup>(3)</sup></b>
SC-2	Sediment/Desilting Basin	
SC-3	Sediment Trap	
SC-4	Check Dam	
SC-5	Fiber Rolls <sup>(4)</sup>	<b>X<sup>(3)</sup></b>

SC-6	Gravel Bag Berm <sup>(4)</sup>	X <sup>(3)</sup>
SC-7	Street Sweeping and Vacuuming	X
SC-8	Sandbag Barrier	X <sup>(3)</sup>
SC-9	Straw Bale Barrier	
SC-10	Storm Drain Protection	X
<b>Wind Erosion Control</b>		
WE-1	Wind Erosion Control <sup>(5)</sup>	X
<b>Tracking Control</b>		
TC-1	Stabilized Construction Entrance/Exit	X
TC-2	Stabilized Construction Roadway	
TC-3	Entrance/Outlet Tire Wash	
<b>Non-Storm Water Management</b>		
NS-1	Water Conservation Practices	X
NS-2	Dewatering Operations <sup>(6)</sup>	X
NS-3	Paving and Grinding Operations	X
NS-4	Temporary Stream Crossing	
NS-5	Clear Water Diversion	
NS-6	Illicit Connection/Illegal Discharge Detection and Reporting	X
NS-7	Potable Water/Irrigation	X
NS-8	Vehicle Equipment Cleaning	X
NS-9	Vehicle Equipment Fueling	X
NS-10	Vehicle Equipment Maintenance	X
NS-11	Pile Driving Operations	
NS-12	Concrete Curing	
NS-13	Material and Equipment Use Over Water	
NS-14	Concrete Finishing	
NS-15	Structure Demolition Over or Adjacent to Water	
NS-16	Temporary Batch Plant	
<b>Waste Management and Material Pollution Control</b>		
WM-1	Material Delivery and Storage	X
WM-2	Material Use	X
WM-3	Stockpile Management	X
WM-4	Spill Prevention and Control	X
WM-5	Solid Waste Management	X
WM-6	Hazardous Waste Management <sup>(7)</sup>	X
WM-7	Contaminated Soil Management	
WM-8	Concrete Waste Management	X
WM-9	Sanitary/Septic Waste Management	X
WM-10	Liquid Waste Management <sup>(8)</sup>	X

(1) This table indicates minimum required BMPs. Additional BMPs may be required as a result of actual field conditions, Contractor activities, or construction operations.

(2) The Contractor shall select and implement one or a combination of soil stabilization BMPs.

- (3) The Contractor shall implement one or a combination of BMPs for prevention of sediment discharges along the perimeter of the Project site.
- (4) One or a combination of BMPs is required to break up the sheet flow lengths (grade breaks for exposed soil).
- (5) The Contractor shall implement effective wind erosion and dust control BMPs in conformance with the requirements of the jurisdictional air quality regulatory agency.
- (6) Required for discharging accumulated precipitation. Separate permits are required for groundwater dewatering.
- (7) Required for vehicles and equipment fueling, cleaning or maintenance, or other construction activities on the Construction site if waste is generated.
- (8) Required for prevention of potential sewage spills as well as for inclusion in any plan for emergency spill cleanup and response.

Table 2-2, “Storm Water Pollution Controls for Construction Activities” is a guide for selection of storm water BMPs. The table is based on Construction activity categories. The Contractor shall use Table 2-2 to select additional BMPs based on the types of construction activities to be conducted on the construction site.

**Table 2-2  
Storm Water Pollution Controls for Construction Activities**

Storm Water Best Management Practices	BMP No.	Categories of Activities																				
		Site Preparation/Earthmoving		Construction of Underground Structures			Construction of Above Ground Structures			Construction of Roadways, Walkways & Parking Lots			Construction in Waterways			Planting & Landscaping						
		Cleaning & Grubbing	Earthwork	Foundations	Conduits (Open Cut)	Drilling	Tunnels	Wood Frame	Structural Steel	Masonry & Concrete	Concrete	Asphalt	Base & Subgrade	Channel Improvement	Water/Sediment Impoundment	Construction Over Water	In Waterway	Adjacent to Water	Irrigation	Seeding & Sodding	Mulching	Planting
<b>Temporary Soil Stabilization</b>																						
Scheduling	SS-1	X	X	X	X	X	X	X	X	X	X	X	X	X	X	X	X	X	X	X		
Preservation of Existing Vegetation	SS-2	X	X	X	X	X	X	X	X	X	X	X	X	X	X	X	X	X	X	X		
Hydraulic Mulch	SS-3	X	X		X													X	X	X		
Hydroseeding	SS-4	X	X		X													X	X	X		
Soil Binders	SS-5	X	X		X													X	X	X		
Straw Mulch	SS-6	X	X		X													X	X	X		
Geotextiles, Plastic Covers & Erosion Control Blankets/Mats	SS-7	X	X		X													X	X	X		
Wood Mulch	SS-8	X	X		X													X	X	X		
Earth Dikes/Drainage Swales & Ditches	SS-9	X	X	X	X						X	X	X	X	X	X	X					
Outlet Protection/Velocity Dissipation Devices	SS-10	X	X								X	X	X	X	X	X	X					
Slope Drains	SS-11	X	X										X	X	X	X	X	X				
Streambank Stabilization	SS-12												X			X						
<b>Temporary Sediment Control</b>																						
Silt Fence	SC-1	X	X	X	X			X	X	X			X	X	X	X	X	X		X	X	X
Desilting Basin	SC-2	X	X	X	X			X	X	X			X	X	X	X	X	X		X	X	X
Sediment Trap	SC-3	X	X	X	X	X	X				X	X	X	X	X	X	X					
Check Dam	SC-4	X	X	X	X	X	X	X	X	X	X	X	X	X	X	X	X	X	X		X	
Fiber Rolls	SC-5	X	X	X	X	X	X			X	X											
Gravel Bag Berm	SC-6	X	X	X	X	X	X						X	X								
Street Sweeping & Vacuuming	SC-7	X	X	X	X	X	X	X	X	X		X	X		X	X						
Sand Bag Barrier	SC-8	X	X		X					X	X	X	X	X	X	X	X	X	X		X	
Straw Bale Barrier	SC-9	X	X		X								X	X	X	X	X					
Storm Drain Inlet Protection	SC-10	X	X		X					X	X	X	X	X	X	X	X					

**Table 2-2 (continued)  
Storm Water Pollution Controls for Construction Activities**

Storm Water Best Management Practices	BMP No.	Categories of Activities																			
		Site Preparation/Earthmoving		Construction of Underground Structures			Construction of Above Ground Structures			Construction of Roadways, Walkways & Parking Lots			Construction in Waterways				Planting & Landscaping				
		Cleaning & Grubbing	Earthwork	Foundations	Conduits (Open Cut)	Drilling	Tunnels	Wood Frame	Structural Steel	Masonry & Concrete	Concrete	Asphalt	Base & Subgrade	Channel Improvement	Water/Sediment Impoundment	Construction Over Water	In Waterway	Adjacent to Water	Irrigation	Seeding & Sodding	Mulching
<b>Wind Erosion</b>																					
Wind Erosion Control	WE-1		X	X	X	X	X						X	X	X	X	X				
<b>Tracking Control</b>																					
Stabilized Construction Entrance/Exit	TC-1	X	X	X	X					X	X	X	X	X		X	X				
Stabilized Construction Roadway	TC-2	X	X	X	X					X	X	X	X	X	X	X	X				
Entrance/Exit Tire Wash	TC-3	X	X		X					X	X	X	X	X		X	X				
<b>Non-Storm Water Management</b>																					
Water Conservation Practices	NS-1	X	X	X	X	X	X	X	X	X	X	X	X	X	X	X	X	X	X		X
Paving & Grinding Operations	NS-3									X	X										
Temporary Stream Crossing	NS-4	X	X	X	X	X	X						X	X							
Clear Water Diversion	NS-5			X	X		X			X	X		X		X	X			X		
Illicit Connection/Illegal Discharge	NS-6	X	X	X	X	X	X	X	X	X	X	X	X	X	X	X	X	X	X		X
Potable Water/Irrigation	NS-7																		X	X	X
Vehicle and Equipment Cleaning	NS-8	X	X	X	X	X	X	X	X	X	X	X	X	X	X	X	X	X	X		X
Vehicle and Equipment Fueling	NS-9	X	X	X	X	X	X	X	X	X	X	X	X	X	X	X	X	X	X		X
Vehicle and Equipment Maintenance	NS-10	X	X	X	X	X	X	X	X	X	X	X	X	X	X	X	X	X	X		X
Pile Driving Operation	NS-11			X																	
Concrete Curing	NS-12									X	X										
Material and Equipment Use Over Water	NS-13														X						
Concrete Finishing	NS-14									X	X										
Structure Demolition/Removal Over or Adjacent to Waters	NS-15												X		X		X				
Temporary Batch Plants	NS-16									X	X	X									

**Table 2-2 (continued)  
Storm Water Pollution Controls for Construction Activities**

Storm Water Best Management Practices	BMP No.	Categories of Activities																		
		Site Preparation/Earthmoving		Construction of Underground Structures			Construction of Above Ground Structures			Construction of Roadways, Walkways & Parking Lots			Construction in Waterways				Planting & Landscaping			
		Clearing & Grubbing	Earthwork	Foundations	Conduits (Open Cut)	Drilling	Tunnels	Wood Frame	Structural Steel	Masonry & Concrete	Concrete	Asphalt	Base & Subgrade	Channel Improvement	Water/Sediment Impoundment	Construction Over Water	In Waterway	Adjacent to Water	Irrigation	Seeding & Sodding
<b>Waste Management &amp; Material Pollution Control</b>																				
Material Delivery & Storage	WM-1	X	X	X	X	X	X	X	X	X	X	X	X	X	X	X	X	X	X	X
Material Use	WM-2	X	X	X	X	X	X	X	X	X	X	X	X	X	X	X	X	X	X	X
Stockpile Management	WM-3	X	X	X	X	X	X				X	X	X	X	X	X	X			
Spill Prevention & Control	WM-4					X	X			X	X			X	X	X	X	X		
Solid Waste Management	WM-5	X	X					X	X	X	X	X	X	X	X	X	X	X	X	X
Hazardous Waste Management	WM-6		X		X	X	X		X											
Contaminated Soil Management	WM-7		X		X	X	X					X								
Concrete Waste Management	WM-8			X		X	X	X	X	X	X			X		X		X		
Sanitary/Septic Waste Management	WM-9	X	X					X	X	X	X	X	X	X	X	X	X	X	X	X
Liquid Waste Management	WM-10					X	X			X	X			X	X	X	X	X	X	X

## 2.2 BMP Inspections and Checklist

To ensure the proper implementation and functioning of water pollution control practices, the Contractor shall regularly inspect and maintain the construction site for the water pollution control practices as follows:

- At a minimum once every week.
- Within 48 hours prior to a qualifying rain event (1/2 inch or more of precipitation with a 48 hour or greater period between rain events);
- Within 48 hours after a qualifying rain event
- At least every 24 hours during extended precipitation events.

Detailed instructions for conducting inspections and filling out the BMP Checklist are included in Appendix B.

## 2.3 BMP Noncompliance and Enforcement Actions

Corrective actions may be required to comply with the SWPPP or contract Special Provisions. The corrective actions identified on the BMP Checklist are required to be completed by the end of the day that the inspection was performed and documented. If the corrective actions identified on the BMP Checklist are not completed by the end of the day, enforcement actions of the contract Special Provisions will be triggered. One of the enforcement tools is the Notice of BMP Noncompliance Form (Appendix C).

When the Engineer identifies that one or more of the BMPs have not been properly implemented and maintained, the Notice of BMP Noncompliance form may be implemented:

1. Part 1 of the Notice of BMP Noncompliance Form will be completed to identify the date of noncompliance, (A) BMP Description, (B) Location, (C) Recommended corrective action(s), and (D) Date Corrective Action to be Completed (within 2 working days).
2. A copy of the form will be given to the Contractor.
3. When the corrective action is completed by the Contractor, the completion date will be entered in Column (E) "Date Corrective Action Completed."
4. If the corrective action is completed by the specified date, "Yes" will be checked in Column (F) Corrective action completed within 2 days.
5. If the corrective action is not completed by the specified date, the Engineer will check "No" in Column (F) indicating the corrective action was not completed within two days, and immediately notify the Environmental Compliance Unit (ECU).
6. Part 2 of the form will be completed if a corrective action was not completed within two days. Contractual Sanctions will be implemented on a daily basis until the recommended corrective action is completed to the satisfaction of the Engineer and the ECU. The date will be written in Column (E) once the corrective action is completed.

Noncompliance for the same violation will result in immediate monetary penalty without allowing 2 days for compliance. It is noted that this form is only one tool and it is up to the Engineer whether additional enforcement is necessary including immediate fines. For example, discharge of concrete waste may result in immediate monetary penalty.

The LACDPW, as a permittee, is subject to enforcement action by the SWRCB, Environmental Protection Agency, private citizens, and citizen groups. The LACDPW will assess the Contractor a penalty of \$1,000 for each calendar day that the Contractor does not fully implement or comply with the provisions set forth in Section 7-8.6 "Water Pollution Control," of the contract Special Provisions, including but not limited to, compliance with the applicable provisions of the Special Provisions, manuals, permits and Federal, State and local regulations. The Contractor shall be responsible for the costs and for liabilities imposed by law as a result of the Contractor's failure to comply with the provisions. Costs and liabilities include, but are not limited to: fines, penalties, and damages, whether assessed against the LACDPW or the Contractor, including those levied under the Federal Clean Water Act and the State Porter Cologne Water Quality Act. In addition the LACDPW will deduct from payments due the Contractor, the total amount of any legal fees, staff costs, and consultant fees as a result of the Contractor's noncompliance with these provisions.



## SECTION 3

### TEMPORARY SOIL STABILIZATION BMPs

#### 3.1 Temporary Soil Stabilization

Temporary soil stabilization is erosion control that consists of protecting or covering exposed areas of soil or stockpiles to minimize erosion by implementing at least one, or **any** combination, of the BMPs shown on Table 3-1. Provide effective soil cover for inactive areas and all finished slopes, open space, utility backfill, and completed lots and inactive portions thereof. Implement appropriate erosion control BMPs (runoff control and soil stabilization) in conjunction with sediment control BMPs for areas under active construction.

#### 3.2 Temporary Concentrated Flow Conveyance Controls

Temporary concentrated flow conveyance controls are erosion controls that consist of BMPs used to intercept, divert, convey and discharge concentrated flows to minimize erosion from within the construction site and downstream of the construction site. Temporary concentrated flow conveyance controls are required to effectively manage all run-on, all runoff within the site and all runoff that discharges from the site. Run-on from offsite shall be directed away from all disturbed areas.

<b>Table 3-1 Temporary Soil Stabilization BMPs</b>	
<b>ID</b>	<b>BMP Name</b>
SS-1	Scheduling
SS-2	Preservation of Existing Vegetation
SS-3	Hydraulic Mulch
SS-4	Hydroseeding
SS-5	Soil Binders
SS-6	Straw Mulch
SS-7	Geotextiles, Plastic Covers, & Erosion Control Blankets/Mats
SS-8	Wood Mulching
<b>Temporary Concentrated Flow Conveyance</b>	
SS-9	Earth Dikes/Drainage Swales & Lined Ditches
SS-10	Outlet Protection/Velocity Dissipation Devices
SS-11	Slope Drains
SS-12	Streambank Stabilization



(This page left intentionally blank)

JANUARY				
MONDAY	TUESDAY	WEDNESDAY	THURSDAY	FRIDAY
		1	2 NTP MOBILIZATION	3
			9	10 Grading
6 Install erosion & sediment control measures	7	8 Land clearing		15
		14		16
12	13			22
				23

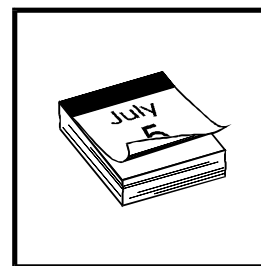

Standard Symbol

- BMP Objectives**

  - Soil Stabilization
  - Sediment Control
  - Tracking Control
  - Wind Erosion Control
  - Non-Storm Water Management
  - Materials and Waste Management

**Definition and Purpose** This best management practice (BMP) involves sequencing of construction activities with the implementation of construction site BMPs such as temporary soil stabilization (erosion control) and temporary sediment control measures. The purpose is to reduce the amount and duration of soil exposed to erosion by wind, rain, runoff and vehicle tracking, and to perform the construction activities and control practices in accordance with the planned schedule.

**Appropriate Applications** Scheduling and planning the project are the very first steps in an effective storm water program and are required for every construction project.

**Limitations** None identified.

- Standards and Specifications**
- Construction sequencing shall be scheduled to minimize land disturbance for all projects throughout the year. Appropriate BMPs shall be implemented on a year round basis. The construction schedule shall be reflected in the SWPPP implementation of BMPs.
  - Schedule year around implementation and deployment of:
    - Temporary soil stabilization BMPs.
    - Temporary sediment control BMPs.
    - Tracking control BMPs.
    - Wind erosion control BMPs.
    - Non-storm water BMPs.
    - Waste management and materials pollution control BMPs.

- Develop the sequencing and timetable for the start and completion of each item such as site clearing and grubbing, grading, excavation, paving, pouring foundations, installing utilities, etc., to minimize the soil disturbing activities during the rainy season.
- Schedule major grading operations for the non-rainy season when practical.
- Stabilize non-active areas within 14 days from the cessation of soil-disturbing activities or one day prior to the onset of precipitation, whichever occurs first.
- Monitor the weather forecast for rainfall.
- When rainfall is predicted, adjust the construction schedule to allow the implementation of soil stabilization and sediment controls and sediment treatment controls on all disturbed areas prior to the onset of rain.
- Be prepared year-round to deploy soil stabilization and sediment control practices. Erosion may be caused during the non-rainy season by unseasonal rainfall, wind, and vehicle tracking. Keep the site stabilized year-round, and retain and maintain sediment tapping devices in operational condition.
- Incorporate staged seeding and re-vegetation of graded slopes as work progresses according to the contract Special Provisions or as directed by the Engineer.
- Apply and maintain temporary erosion and sediment controls to all areas until permanent stabilization has been established.
- Review and update project site weekly.
- Verify that work is progressing in accordance with the schedule. If progress deviates, take corrective actions.
- Amend the schedule when changes are warranted or when directed by the Engineer.

## Maintenance and Inspection



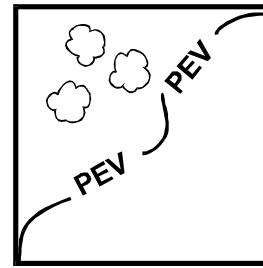
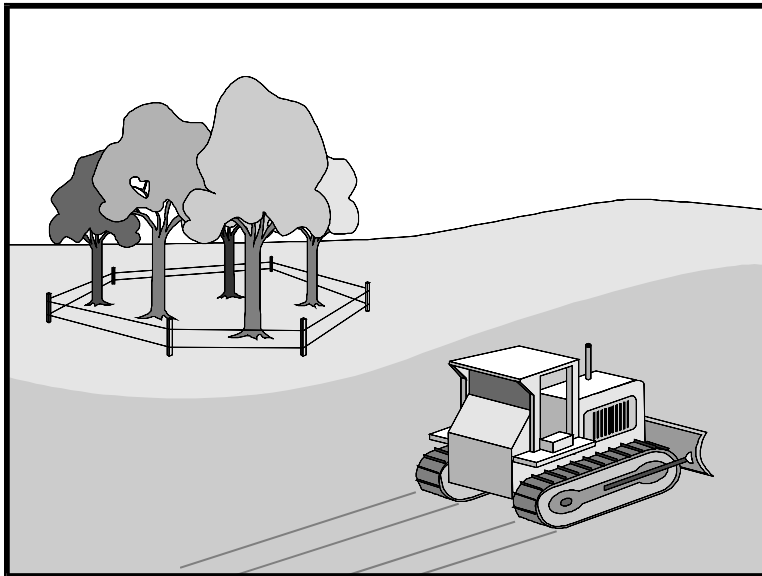

Standard Symbol

- BMP Objectives**

  - Soil Stabilization
  - Sediment Control
  - Tracking Control
  - Wind Erosion Control
  - Non-Storm Water Management
  - Materials and Waste Management

**Definition and Purpose** Preservation of existing vegetation is the identification and protection of desirable vegetation that provides erosion and sediment control benefits.

- Appropriate Applications**
- Preserve existing vegetation at areas on a site where no construction activity is required by the contract Special Provisions.
  - On a year-round basis, temporary fencing shall be installed at the limits clearing and grubbing operations and other soil-disturbing activities. The temporary fencing shall be installed prior to commencement of clearing and grubbing operations and other soil-disturbing activities
  - Clearing and grubbing operations shall be staged to preserve existing vegetation.

**Limitations** Protection of existing vegetation requires planning, and may limit the area available for construction activities.

**Standards and Specifications** Do NOT drive over vegetation or store materials on vegetation or otherwise disturb vegetation outside construction project boundaries shown on the project plans.

**Schedule**

- The Contractor shall not prune or remove any trees for any reason during the nesting season (see contract Special Provisions) for migratory non-game native bird species, including raptors.
- If approved by the Engineer, the Contractor may prune or remove any trees during the nesting season. The Contractor will coordinate with the Agency to provide all required bird surveys to detect any protected native birds in the trees to be removed and other suitable nesting habitat.

- If a protected native bird is found, the Agency will delay all clearance/construction disturbance activities in suitable nesting habitat or continue the surveys in order to locate any nests. If an active nest is located, clearance/construction disturbance activities shall be delayed until the nest is vacated and juveniles have fledged and when there is no evidence of a second attempt at nesting. Limits of construction to avoid a nest shall be established in the field by the Agency.
- Refer to contract Special Provisions for any other provisions or requirements for the preservation vegetation.

## ***Design and Layout***

- Mark areas to be preserved with temporary fencing.
- Minimize the disturbed areas by locating temporary roadways, stockpiles and layouts areas to avoid stands of trees, shrubs, and grass. Follow existing contours to reduce cutting and filling.

## ***Installation***

- Construction materials, equipment storage, and parking areas shall be located where they will not cause root compaction.
- Keep equipment away from trees to prevent trunk and root damage.
- Maintain existing irrigation systems.
- Employees and subcontractors shall be trained to perverse protective devices. No heavy equipment, vehicular traffic, or storage piles of any construction materials shall be permitted within the drip line of any tree to be remain. Removed trees shall not be felled, pushed, or pulled into any retained trees. No toxic or construction materials (including paint, acid, nails, gypsum board, chemicals, fuels, and lubricants) shall be stored within 50 feet of the drip line of any retained trees, nor disposed of in any way which would impact vegetation.

## ***Trenching and Tunneling***

- Trenching shall be as far away from tree trunks as possible, usually outside of the tree drip line or canopy. Curve trenches around trees to avoid large roots or root concentrations. If roots are encountered, consider tunneling under them. When trenching and/or tunneling near or under trees to be retained, tunnels shall be at least 18 inches below the ground surface, and not below the tree center to minimize impact on the roots.
- Tree roots shall not be left exposed to air; they shall be covered with soil as soon as possible, protected, and kept moistened with wet burlap or peat moss until the tunnel and/or trench can be completed.

- The ends of damaged or cut roots shall be cut off smoothly.
- Trenches and tunnels shall be backfilled as soon as possible. Careful backfilling and compacting will eliminate air spaces in the soil which can damage roots.
- After all other work is complete, fences and barriers shall be removed last. This is because protected trees may be destroyed by carelessness during the final cleanup and landscaping.

## Maintenance and Inspection

During construction, the limits of disturbance shall remain clearly marked at all times. Irrigation or maintenance of existing vegetation shall conform to the requirements in the landscaping plan. If damage to protected trees still occurs, maintenance guidelines described below shall be followed:

- Verify that protective measures remain in place. Restore damaged protection measures immediately
- Serious tree injuries shall be attended to by an arborist.
- Damage to the crown, trunk, or root system of a retained tree shall be repaired immediately.
- Trench as far from tree trunks as possible, usually outside of the tree drip line or canopy. Curve trenches around trees to avoid large roots or root concentrations. If roots are encountered, consider tunneling under them. When trenching or tunneling near or under trees to be retained, place tunnels at least 18 in. below the ground surface, and not below the tree center to minimize impact on the roots.
- Do not leave tree roots exposed to air. Cover exposed roots with soil as soon as possible. If soil covering is not practical, protect exposed roots with wet burlap or peat moss until the tunnel or trench is ready for backfill.
- Cleanly remove the ends of damaged roots with a smooth cut.
- Remove any trees intended for retention if those trees are damaged seriously enough to affect their survival, as determined by the Engineer. If replacement is required, the new tree shall be of similar species, as required by the contract special provisions or as directed by the Engineer.
- If bark damage occurs, cut back all loosened bark into the undamaged area, with the cut tapered at the top and bottom and drainage provided at the base of the wood. Limit cutting the undamaged area as much as possible.
- Aerate soil that has been compacted over a trees root zone by punching holes 12 in. deep with an iron bar, and moving the bar back and forth until the soil is loosened. Place holes 18 in. apart throughout the area of compacted soil under the tree crown.

- Fertilization
  - Fertilize stressed or damaged broadleaf trees to aid recovery.
  - Fertilize trees in the late fall or early spring.
  - Apply fertilizer to the soil over the feeder roots and in accordance with label instructions, but never closer than 3 ft to the trunk. Increase the fertilized area by one-fourth of the crown area for conifers that have extended root systems.
  - Discontinue the application of any erodible landscape material within 2 days before a forecasted rain event or during periods of precipitation.
  - Follow WM-1 for storage of fertilizers.
- Retain protective measures until all other construction activity is complete to avoid damage during site cleanup and stabilization.
- Inspect existing vegetation weekly and before and after every rainfall events. During extended rainfall events, inspect existing vegetation at least once every 24 hours.



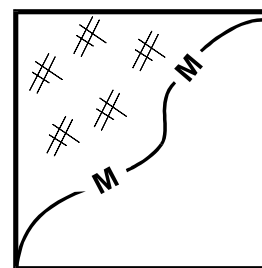
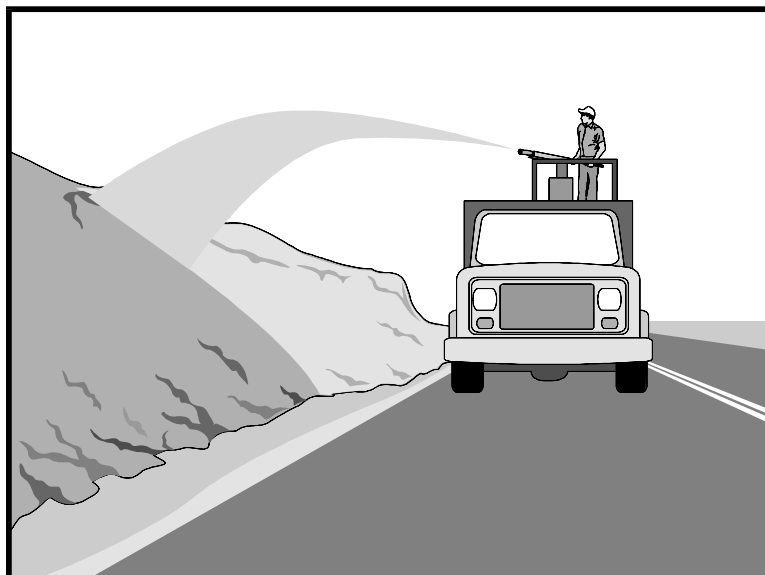

Standard Symbol

- BMP Objectives**
- Soil Stabilization
  - Sediment Control
  - Tracking Control
  - Wind Erosion Control
  - Non-Storm Water Management
  - Materials and Waste Management

**Definition and Purpose** Hydraulic mulch consists of applying a mixture of shredded wood fiber or a hydraulic matrix and a stabilizing emulsion or tackifier with hydroseeding equipment, which temporarily protects exposed soil from erosion by raindrop impact or wind. This is one of five temporary soil stabilization alternatives to consider.

**Appropriate Applications**

- Hydraulic mulch is applied to disturbed areas requiring temporary protection until permanent vegetation is established or to disturbed areas that must be re-disturbed following a period of inactivity.

**Limitations**

- Wood fiber hydraulic mulches are generally short-lived (only last a part of a growing season) and need 24 hours to dry before rainfall occurs to be effective.

- Paper mulches alone are not permitted. Paper mulch is allowed if in combination with other mulch such as wood.

- Avoid use in areas where the mulch would be incompatible with immediate future earthwork activities and would have to be removed.

**Standards and Specifications**

- Prior to application, roughen embankment and fill areas by rolling with a crimping or punching type roller or by track walking. Track walking shall only be used where other methods are impractical.

- Avoid mulch over-spray onto the roadway, sidewalks, lined drainage channels, and existing vegetation.

- Selection of hydraulic mulches by the Contractor must be approved by the Engineer.

## ***Hydraulic Mulch***

- Wood fiber mulch can be applied alone or as a component of hydraulic matrices. Wood fiber mulch shall be applied per manufacture's recommendations typically at the rate of 2,000 to 4,000 lb/ac. This type of mulch is manufactured from wood or wood waste from lumber mills or from urban sources.

## ***Hydraulic Matrices***

- Hydraulic matrices include a mixture of wood fiber mulch and tackifier applied as slurry. It is typically applied at the rate of 2,000 to 4,000 lb/ac with 5-10% by weight of a stabilizing emulsion or tackifier (e.g., guar, psyllium, acrylic copolymer, polyacrylamide).

## ***Bonded Fiber Matrix***

- Bonded fiber matrix (BFM) is a hydraulically-applied system of fibers and adhesives that upon drying forms an erosion-resistant blanket that promotes vegetation, and prevents soil erosion. BFMs are typically applied at rates from 3,000 to 4,500 lb/ac based on the manufacturer's recommendation. The biodegradable BFM is composed of materials that are 100% biodegradable. The binder in the BFM should also be biodegradable and should not dissolve or disperse upon re-wetting. Typically, biodegradable BFMs should not be applied immediately before, during or immediately after rainfall if the soil is saturated. Depending on the product, BFMs require 12 to 24 hours to dry to become effective.

## **Maintenance and Inspections**

- Inspect hydraulic mulched slopes and areas weekly and before and after every rainfall events. During extended rainfall events, inspect hydraulic mulched slopes and areas at least once every 24 hours.
- Maintain an unbroken, temporary mulched ground cover throughout the period of construction when the soils are not being reworked.
- The Contractor is responsible for maintaining all slopes to prevent erosion for the duration of the project or per the contract Special Provisions.

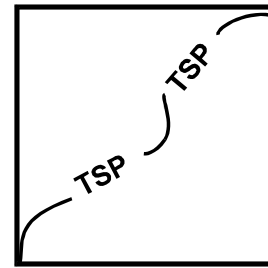
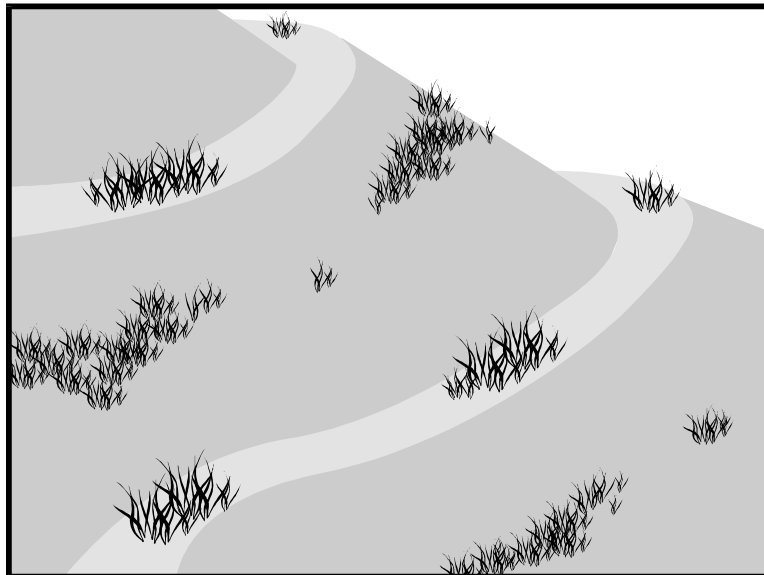

Standard Symbol

### BMP Objectives

- Soil Stabilization
- Sediment Control
- Tracking Control
- Wind Erosion Control
- Non-Storm Water Management
- Materials and Waste Management

**Definition and Purpose** Hydroseeding typically consists of applying a mixture of wood fiber, seed, fertilizer, and stabilizing emulsion with hydro-seeding equipment, which temporarily protects exposed soils from erosion by water and wind.

**Appropriate Applications**

- Hydroseeding is applied on disturbed soil areas requiring temporary protection until permanent vegetation is established or disturbed soil areas that must be re-disturbed following an extended period of inactivity.
- Hydroseeding mix shall be per the contract Special Provisions or approved by the Engineer.

**Limitations**

- Hydroseeding may be used alone only when there is sufficient time in the season to ensure adequate vegetation establishment and erosion control. Otherwise, hydroseeding must be used in conjunction with a soil binder or mulching (i.e., straw mulch), refer to BMP SS-5, Table 1 for options.
- Steep slopes are difficult to protect with temporary seeding.
- Temporary seeding may not be appropriate in dry periods without supplemental irrigation.
- Temporary vegetation may have to be removed before permanent vegetation is applied.
- Temporary vegetation is not appropriate for short-term inactivity.

**Standards and Specifications** To select appropriate hydroseeding mixtures, an evaluation of site conditions shall be performed with respect to:

- Soil conditions
- Site topography
- Season and climate
- Vegetation types
- Maintenance requirements
- Sensitive adjacent areas
- Water availability
- Plans for permanent vegetation

The following steps shall be followed for implementation:

- Hydroseeding can be accomplished using a multiple-step or one-step process. The multiple-step process ensures maximum direct contact of the seeds to soil. When the one-step process is used to apply the mixture of fiber, seed, etc., the seed rate shall be increased to compensate for all seeds not having direct contact with the soil.
- Prior to application, roughen the slope, fill area, or area to be seeded with the furrows trending along the contours. Rolling with a crimping or punching type roller or track walking is required on all slopes prior to hydroseeding.
- Apply a straw mulch to keep seeds in place and to moderate soil moisture and temperature until the seeds germinate and grow.
- All seeds shall be in conformance with the California State Seed Law of the Department of Agriculture. Each seed bag shall be delivered to the site sealed and clearly marked as to species, purity, percent germination, dealer's guarantee, and dates of test; provide the Engineer with such documentation. The container shall be labeled to clearly reflect the amount of Pure Live Seed (PLS) contained.
- Commercial fertilizer shall conform to the requirements of the California Food and Agricultural Code. Fertilizer shall be in pellet or granular form.
- Follow-up applications shall be made as needed to cover bare spots, and to maintain adequate soil protection.
- Avoid over-spray onto the travel way, sidewalks, lined drainage channels, and existing vegetation.

**Maintenance and Inspection**

- Inspect hydroseeded slopes and areas weekly and before and after every rainfall events. During extended rainfall events, inspect hydroseeded slopes and areas at least once every 24 hours.
- All seeded areas shall be inspected for failures and re-seeded, fertilized, and mulched within the planting season, using not less than half the original application rates. Any temporary revegetation efforts that do not provide adequate cover must be reapplied as required by the Engineer.
- The Contractor is responsible for maintaining all slopes to prevent erosion for the duration of the project or per the contract Special Provisions.

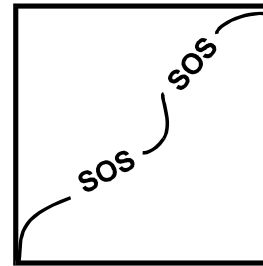
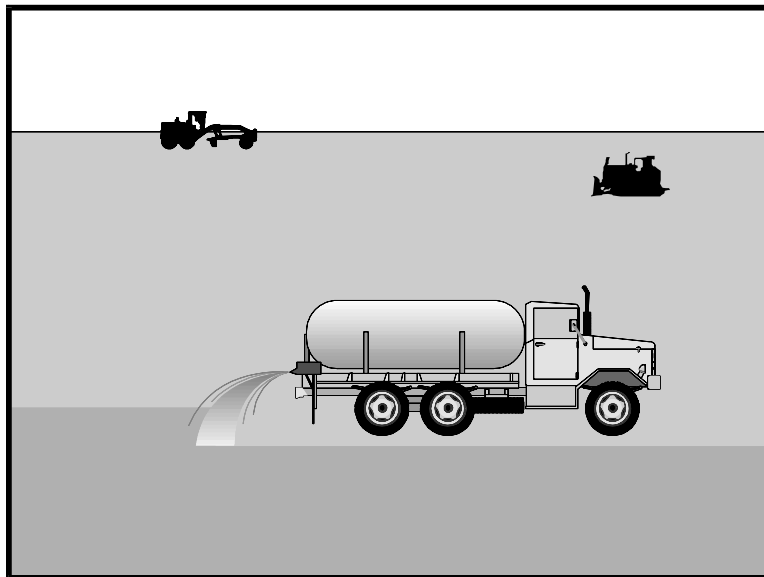

Standard Symbol

### BMP Objectives

- Soil Stabilization
- Sediment Control
- Tracking Control
- Wind Erosion Control
- Non-Storm Water Management
- Materials and Waste Management

**Definition and Purpose** Soil binders consist of applying and maintaining a soil stabilizer to exposed soil surfaces. Soil binders are materials applied to the soil surface to temporarily prevent water-induced erosion of exposed soils on construction sites. Soil binders also provide temporary dust, wind, and soil stabilization (erosion control) benefits. This is one of five temporary soil stabilization alternatives to consider.

**Appropriate Applications** Soil binders are typically applied to disturbed areas requiring short-term temporary protection. Because soil binders can often be incorporated into the work, they may be a good choice for areas where grading activities will soon resume. Application on stockpiles to prevent water and wind erosion is an additional appropriate use.

- Limitations**
- Soil binders are temporary in nature and may need reapplication.
  - Soil binders require a minimum curing time until fully effective which may be 24 hours or longer. Soil binders may need reapplication after a storm event.
  - Soil binders will generally experience spot failures during heavy rainfall events. If runoff penetrates the soil at the top of a slope treated with a soil binder, it is likely that the runoff will undercut the stabilized soil layer.
  - Soil binders do not hold up to pedestrian or vehicular traffic across treated areas.
  - Some soil binders are incompatible with existing vegetation.
  - Soil binders may not penetrate soil surfaces made up primarily of silt and clay, particularly when compacted.
  - Performance of soil binders depends on temperature, humidity, and traffic across treated areas.

## Standards and Specifications

### **General Considerations**

- Soil binder shall be approved by the Engineer prior to application.
- Site-specific soil types will dictate the appropriate soil binders to be used.
- A soil binder shall be environmentally benign (non-toxic to plant and animal life), easy to apply, easy to maintain, economical, and shall not stain paved or painted surfaces.
- Avoid over-spray onto the travel way, sidewalks, lined drainage channels, and existing vegetation.

### **Soil Binders Applications**

After selecting an appropriate soil binder, the untreated soil surface must be prepared before applying the soil binder. The untreated soil surface must contain sufficient moisture to assist the agent in achieving uniform distribution. In general, the following steps shall be followed:

- Follow manufacturer's recommendations for application rates, pre-wetting of application area, and cleaning of equipment after use.
- Prior to application, roughen embankment and fill areas by rolling with a crimping or punching type roller or by track walking. Track walking shall only be used where rolling is impractical. Crown or slope ground to avoid ponding.
- Consider the drying time for the selected soil binder and apply with sufficient time before anticipated rainfall. Soil binders shall not be applied during or immediately before rainfall.
- Soil binders shall not be applied to frozen soil, areas with standing water, under freezing or rainy conditions, or when the air temperature is below 40C (40°F) during the curing period.
- More than one treatment is often necessary, although the second treatment may be diluted or have a lower application rate.
- Generally, soil binders require a minimum curing time before they are fully effective. Refer to manufacturer's recommendations for specific cure times.
- Uniformly pre-wet ground at a rate of 0.03 to 0.3 gal/yd<sup>2</sup> or according to manufacturer's recommendations. In low humidity, reactivate chemicals by re-wetting with water at a rate of 0.1 to 0.2 gal/yd<sup>2</sup>.
- Apply soil binder solution under pressure. Overlap spray pattern by 6 to 12 inches.
- Allow treated area to cure for the time recommended by the manufacturer; typically, at least 24 hours.

## Selecting a Soil Binder

Properties of common soil binders used for erosion control are provided in Table 1. Use Table 1 to select an appropriate soil binder.

Factors to consider when selecting a soil binder include the following:

- Suitability to situation - Consider where the soil binder will be applied; determine if it needs a high resistance to leaching or abrasion, and whether it needs to be compatible with any existing vegetation. Determine the length of time soil stabilization will be needed, and if the soil binder will be placed in an area where it will degrade rapidly. In general, slope steepness is not a discriminating factor for the listed soil binders.
- Soil types and surface materials - Fines and moisture content are key properties of surface materials. Consider a soil binder's ability to penetrate, leaching potential, and ability to form a surface crust on the surface materials.
- Frequency of application - The frequency of application can be affected by subgrade conditions, surface type, climate, and maintenance schedule. Frequent applications could lead to high costs. Application frequency may be minimized if the soil binder has good penetration, low evaporation, and good longevity. Consider also that frequent application will require frequent equipment clean-up.

After considering the above factors, the soil binders in Table 1 will be generally appropriate as follows:

### Plant-Material Based (Short Lived)

*-Guar:* Guar is a non-toxic, biodegradable, natural galactomannan-based hydrocolloid treated with dispersent agents for easy field mixing. It shall be diluted at the rate of 1 to 5 lb per 100 gallons of water, depending on application machine capacity. Recommended minimum application rates are as follows:

#### Application Rates for Guar Soil Stabilizer

Slope (V:H):	Flat	1:4	1:3	1:2	1:1
lb/ac	40	45	50	60	70

*-Psyllium:* Psyllium is composed of the finely ground muciloid coating of plantago seeds that is applied as a dry powder or in a wet slurry to the surface of the soil. It dries to form a firm but rewettable membrane that binds soil particles together but permits germination and growth of seed. Psyllium requires 12 to 18 hours drying time. Psyllium shall be applied at a rate of 80 to 200 lb/ac, with enough water in solution to allow for a uniform slurry flow.

-*Starch*: Starch is non-ionic, cold-water soluble (pre-gelatinized) granular cornstarch. The material is mixed with water and applied at the rate of 150 lb/ac. Approximate drying time is 9 to 12 hours.

## **Plant-Material Based (Long Lived)**

-*Pitch and Rosin Emulsion*: Generally, a non-ionic pitch and rosin emulsion has a minimum solids content of 48%. The rosin shall be a minimum of 26% of the total solids content. The soil stabilizer shall be non-corrosive, water-dilutable emulsion that upon application cures to a water insoluble binding and cementing agent. For soil erosion control applications, the emulsion is diluted and shall be applied as follows:

For clayey soil: 5 parts water to 1 part emulsion

For sandy soil: 10 parts water to 1 part emulsion

Application can be by water truck or hydraulic seeder with the emulsion/product mixture applied at the rate specified by the manufacturer. Approximate drying time is 19 to 24 hours.

## **Polymeric Emulsion Blends**

-*Acrylic Copolymers and Polymers*: Polymeric soil stabilizers shall consist of a liquid or solid polymer or copolymer with an acrylic base that contains a minimum of 55% solids. The polymeric compound shall be handled and mixed in a manner that will not cause foaming or shall contain an anti-foaming agent. The polymeric emulsion shall not exceed its shelf life or expiration date; manufacturers shall provide the expiration date. Polymeric soil stabilizer shall be readily miscible in water, non-injurious to seed or animal life, non-flammable, shall provide surface soil stabilization for various soil types without totally inhibiting water infiltration, and shall not re-emulsify when cured. The applied compound shall air cure within a maximum of 36 to 48 hours. Liquid copolymer shall be diluted at a rate of 10 parts water to 1 part polymer and applied to soil at a rate of 1,175 gal/ac.

-*Liquid Polymers of Methacrylates and Acrylates*: This material consists of a tackifier/sealer that is a liquid polymer of methacrylates and acrylates. It is an aqueous 100% acrylic emulsion blend of 40% solids by volume that is free from styrene, acetate, vinyl, ethoxylated surfactants or silicates. For soil stabilization applications, it is diluted with water in accordance with manufacturer's recommendations, and applied with a hydraulic seeder at the rate of 20 gal/ac. Drying time is 12 to 18 hours after application.

-*Copolymers of Sodium Acrylates and Acrylamides*: These materials are non-toxic, dry powders that are copolymers of sodium acrylate and acrylamide. They are mixed with water and applied to the soil surface for erosion control at rates that are determined by slope gradient:



Slope Gradient (V:H)	lb/ac
Flat to 1:5	3-5
1:5 to 1:3	5-10
1:2 to 1:1	10-20

*-Poly-Acrylamide and Copolymer of Acrylamide:* Linear copolymer polyacrylamide is packaged as a dry-flowable solid. When used as a stand-alone stabilizer, it is diluted at a rate of 1 lb/100 gal of water and applied at the rate of 5 lb/ac.

*-Hydro-Colloid Polymers:* Hydro-Colloid Polymers are various combinations of dry-flowable poly-acrylamides, copolymers and hydro-colloid polymers that are mixed with water and applied to the soil surface at rates of 53 to 62 lb/ac. Drying times are 0 to 4 hours.

### Maintenance and Inspection

- Inspect slopes stabilized with soil binders weekly and before and after every rainfall events. During extended rainfall events, inspect slopes stabilized with soil binders at least once every 24 hours.
- Reapplying the selected soil binder may be needed for proper maintenance. High traffic areas shall be inspected daily, and lower traffic areas shall be inspected weekly.
- The Contractor is responsible for maintaining all slopes to prevent erosion for the duration of the project or per the contract Special Provisions.
- Maintain an unbroken, temporary stabilized area while disturbed soil areas are nonactive. Repair any damaged stabilized area and re-apply soil binder to exposed areas.

Chemicals	Plant Material Based (Short Lived)	Plant Material Based (Long Lived)	Polymeric Emulsion Blends
Relative Cost	Low	Low	Low
Resistance to Leaching	High	High	Low to Moderate
Resistance to Abrasion	Moderate	Low	Moderate to High
Longevity	Short to Medium	Medium	Medium to Long
Minimum Curing Time before Rain	9 to 18 hours	19 to 24 hours	0 to 24 hours
Compatibility with Existing Vegetation	Good	Poor	Poor
Mode of Degradation	Biodegradable	Biodegradable	Photodegradable/ Chemically Degradable
Labor Intensive	No	No	No
Specialized Application Equipment	Water Truck or Hydraulic Mulcher	Water Truck or Hydraulic Mulcher	Water Truck or Hydraulic Mulcher
Liquid/Powder	Powder	Liquid	Liquid/Powder
Surface Crusting	Yes, but dissolves on rewetting	Yes	Yes, but dissolves on rewetting
Clean-Up	Water	Water	Water
Erosion Control Application Rate	Varies <sup>(1)</sup>	Varies <sup>(1)</sup>	Varies <sup>(1)</sup>

(1) Dependant on product, soil type, and slope inclination

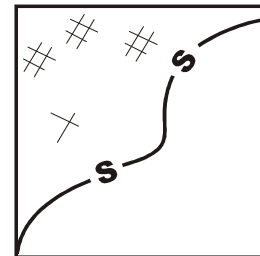
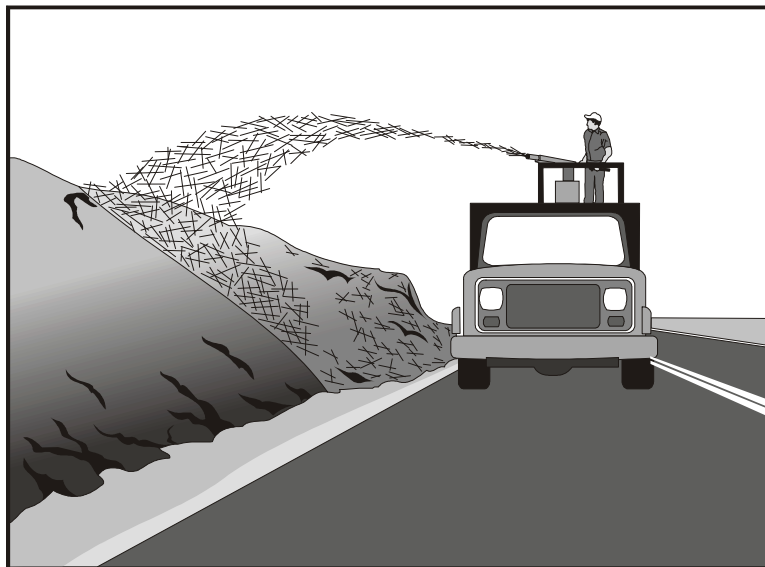

Standard Symbol

- BMP Objectives**
- Soil Stabilization
  - Sediment Control
  - Tracking Control
  - Wind Erosion Control
  - Non-Storm Water Management
  - Materials and Waste Management

**Definition and Purpose** Straw mulch consists of placing a uniform layer of straw and incorporating it into the soil with a studded roller or anchoring it with a stabilizing emulsion. This is one of five temporary soil stabilization alternatives to consider.

- Appropriate Applications**
- Straw mulch is typically used for soil stabilization as a temporary surface cover on disturbed areas until soils can be prepared for revegetation and permanent vegetation is established.
  - Also typically used in combination with temporary and/or permanent seeding strategies to enhance plant establishment.

- Limitations**
- Use of Straw Mulch shall be approved by Engineer
  - There is a potential for introduction of weed-seed and unwanted plant material.
  - When straw blowers are used to apply straw mulch, the treatment areas must be within 150 feet of a road or surface capable of supporting trucks.
  - Mulch may have to be removed prior to permanent seeding or soil stabilization.
  - “Punching” of straw does not work in loose sandy soils or very compact soils.

## Standards and Specifications

- Straw shall be derived from wheat, rice, or barley.
- A tackifier is the preferred method for anchoring straw mulch to the soil on slopes.
- Crimping, punch roller-type rollers, or track-walking may also be used to incorporate straw mulch into the soil on slopes. Track walking shall only be used where other methods are impractical.
- Avoid placing straw onto the travel way, sidewalks, lined drainage channels, sound walls, and existing vegetation.
- Straw mulch with tackifier shall not be applied during or immediately before rainfall.

## Application Procedures

- Apply loose straw per contract Special Provisions, or at a minimum rate of 4,000 lb/ac, either by machine or by hand distribution.
- If stabilizing emulsion will be used to anchor the straw mulch in lieu of incorporation, roughen embankment or fill areas by rolling with a crimping or punching-type roller or by track walking before placing the straw mulch. Track walking should only be used where rolling is impractical.
- The straw mulch must be evenly distributed on the soil surface.
- Anchor the mulch in place by using a tackifier or by “punching” it into the soil mechanically (incorporating).
- A tackifier acts to glue the straw fibers together and to the soil surface. The tackifier shall be selected based on longevity and ability to hold the fibers in place. A tackifier is typically applied at a rate of 125 lb/ac. In windy conditions, the rates are typically 178 lb/ac.
- Methods for holding the straw mulch in place depend upon the slope steepness, accessibility, soil conditions and longevity. Install straw mulch into the soil as follows:
  - On small areas, a spade or shovel can be used.
  - On slopes with soils, which are stable enough and of sufficient gradient to safely support construction equipment without contributing to compaction and instability problems, straw can be “punched” into the ground using a knife-blade roller or a straight bladed coulter, known commercially as a “crimper.”
  - On small areas and/or steep slopes, straw can also be held in place using plastic netting or jute. The netting shall be held in place using 11 gauge wire staples, geotextile pins or wooden stakes. Refer to BMP SS-7, “Geotextiles, Plastic Covers and Erosion Control Blankets/Mats.”

## Maintenance and Inspections

- The key consideration in maintenance and inspection is that the straw needs to last long enough to achieve erosion control objectives.
- Inspect areas stabilized with straw mulch weekly and before and after every rainfall events. During extended rainfall events, inspect areas stabilized with straw mulch at least once every 24 hours.
- Maintain an unbroken, temporary mulched ground cover while disturbed soil areas are non-active. Repair any damaged ground cover and re-mulch exposed areas.
- Reapplication of straw mulch and tackifier may be required by the Engineer to maintain effective soil stabilization over disturbed areas and slopes.
- The Contractor is responsible for maintaining all slopes to prevent erosion for the duration of the project or per the contract Special Provisions.

(This page left intentionally blank)

# Geotextiles, Mats, Plastic Covers and Erosion Control Blankets

SS-7

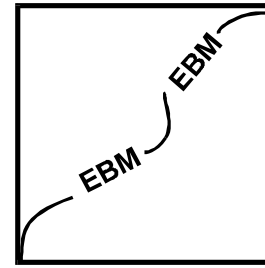
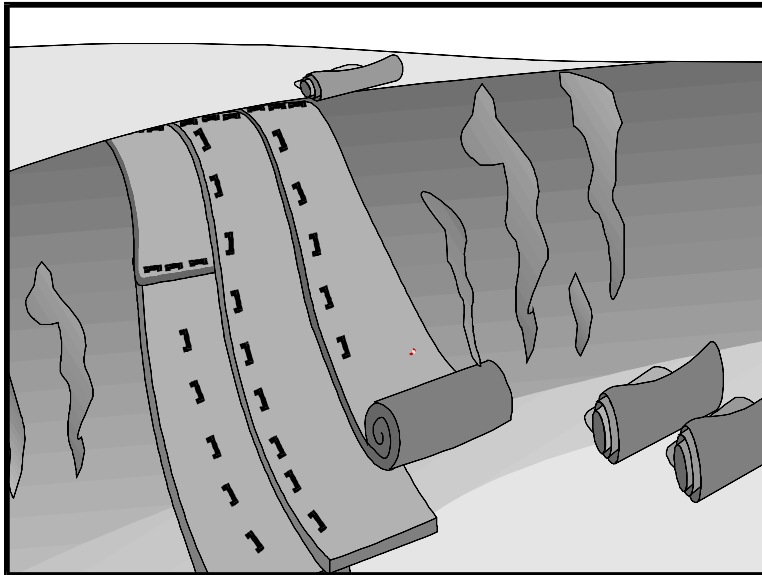

Standard Symbol

### BMP Objectives

- Soil Stabilization
- Sediment Control
- Tracking Control
- Wind Erosion Control
- Non-Storm Water Management
- Materials and Waste Management

**Definition and Purpose** This Best Management Practice (BMP) involves the placement of geotextiles, mats, plastic covers, or erosion control blankets to stabilize disturbed soil areas and protect soils from erosion by wind or water. This is one of five temporary soil stabilization alternatives to consider.

**Appropriate Applications** These measures are used when disturbed soils may be particularly difficult to stabilize, including the following situations:

- Steep slopes, generally steeper than 1:3 (V:H).
- Slopes where the erosion potential is high, adjacent to water bodies, or Environmentally Sensitive Areas (ESAs).
- Slopes and disturbed soils where mulch must be anchored.
- Disturbed areas where plants are slow to develop.
- Channels with high flow velocities.
- Stockpiles.

**Limitations**

- Blankets and mats are more expensive than other erosion control measures, due to labor and material costs. This usually limits their application to areas inaccessible to hydraulic equipment, or where other measures are not applicable, such as channels.
- Blankets and mats are generally not suitable for excessively rocky sites, or areas where the final vegetation will be mowed (since staples and netting can catch in mowers).
- Blankets and mats must be removed and disposed of prior to application of permanent soil stabilization measures.



- Plastic sheeting is easily vandalized, easily torn, photodegradable, and must be disposed of as solid waste.
- Plastic results in 100% runoff, which may cause serious erosion problems in the areas receiving the increased flow.
- The use of plastic shall be limited to covering stockpiles, or very small graded areas for short periods of time (such as through one imminent storm event), until alternative measures, such as seeding and mulching, may be installed.
- Geotextiles, mats, plastic covers, and erosion control covers have maximum flow rate limitations; consult the manufacturer for proper selection.

## Standards and Specifications **Material Selection**

There are many types of erosion control blankets and mats, and selection of the appropriate type shall be based on the specific type of application and site conditions.

### **Geotextiles**

- Material shall be a woven polypropylene fabric with minimum thickness of 0.06 inch, minimum width of 12 ft and shall have minimum tensile strength of 150 lbs (warp), 80 lbs (fill) in conformance with the requirements in ASTM Designation: D 4632. The permittivity of the fabric shall be approximately  $0.07 \text{ sec}^{-1}$  in conformance with the requirements in ASTM Designation: D4491. The fabric shall have an ultraviolet (UV) stability of 70 percent in conformance with the requirements in ASTM designation: D4355. Geotextile blankets shall be secured in place with wire staples or sandbags and by keying into tops of slopes and edges to prevent infiltration of surface waters under the geotextile. Staples shall be made of 11 gauge steel wire and shall be U-shaped with 8-inch legs and 2-inch crown.

### **Plastic Covers**

- Plastic sheeting shall have a minimum thickness of 6 mils, and shall be keyed in at the top of the slope and firmly held in place with sandbags or other weights placed no more than 10 ft apart. Seams are typically taped or weighted down their entire length, and there shall be an overlap of at least 12 to 24 inches at all seams. Edges shall be embedded a minimum of 6 inches in soil.

### **Erosion Control Blankets/Mats**

- Biodegradable rolled erosion control products (RECPs) are typically composed of jute fibers, curled wood fibers, straw, coconut fiber, or a combination of these materials. For an RECP to be considered 100% biodegradable, the netting, sewing or adhesive system that holds the biodegradable mulch fibers together must also be biodegradable.



- **Jute** is a natural fiber that is made into a yarn, which is loosely woven into a biodegradable mesh. It is designed to be used in conjunction with vegetation and has limited longevity. The material is supplied in rolled strips, which shall be secured to the soil with U-shaped staples or stakes in accordance with manufacturers' recommendations.
- **Excelsior (curled wood fiber)** blanket material shall consist of machine produced mats of curled wood excelsior with 80 percent of the fiber 6 inches or longer. The excelsior blanket shall be of consistent thickness. The wood fiber shall be evenly distributed over the entire area of the blanket. The top surface of the blanket shall be covered with a photodegradable extruded plastic mesh. The blanket shall be smolder resistant without the use of chemical additives and shall be non-toxic and non-injurious to plant and animal life. Excelsior blanket shall be furnished in rolled strips, a minimum of 48 inches wide, and shall have an average weight of 0.8 lb/yd<sup>2</sup>, ±10 percent, at the time of manufacture. Excelsior blankets shall be secured in place with wire staples. Staples shall be made of 11 gauge steel wire and shall be U-shaped with 8-inch legs and 2-inch crown.
- **Straw blanket** shall be machine-produced mats of straw with a lightweight biodegradable netting top layer. The straw shall be attached to the netting with biodegradable thread or glue strips. The straw blanket shall be of consistent thickness. The straw shall be evenly distributed over the entire area of the blanket. Straw blanket shall be furnished in rolled strips a minimum of 6.5 ft wide, a minimum of 80 ft long and a minimum of 0.5 lb/yd<sup>2</sup>. Straw blankets shall be secured in place with wire staples. Staples shall be made of 11 gauge steel wire and shall be U-shaped with 8-inch legs and 2-inch crown.
- **Wood fiber blanket** is composed of biodegradable fiber mulch with extruded plastic netting held together with adhesives. The material is designed to enhance revegetation. The material is furnished in rolled strips, which shall be secured to the ground with U-shaped staples or stakes in accordance with manufacturers' recommendations.
- **Coconut fiber blanket** shall be machine-produced mats of 100% coconut fiber with biodegradable netting on the top and bottom. The coconut fiber shall be attached to the netting with biodegradable thread or glue strips. The coconut fiber blanket shall be of consistent thickness. The coconut fiber shall be evenly distributed over the entire area of the blanket. Coconut fiber blanket shall be furnished in rolled strips with a minimum of 6.5 ft wide, a minimum of 80 ft long and a minimum of 0.5 lb/yd<sup>2</sup>. Coconut fiber blankets shall be secured in place with wire staples. Staples shall be made of 11 gauge steel wire and shall be U-shaped with 8-inch legs and 2-inch crown.
- **Coconut fiber mesh** is a thin permeable membrane made from coconut

or corn fiber that is spun into a yarn and woven into a biodegradable mat. It is designed to be used in conjunction with vegetation and typically has longevity of several years. The material is supplied in rolled strips, which shall be secured to the soil with U-shaped staples or stakes in accordance with manufacturers' recommendations.

- **Straw coconut fiber blanket** shall be machine-produced mats of 70% straw and 30% coconut fiber with a biodegradable netting top layer and a biodegradable bottom net. The straw and coconut fiber shall be attached to the netting with biodegradable thread or glue strips. The straw coconut fiber blanket shall be of consistent thickness. The straw and coconut fiber shall be evenly distributed over the entire area of the blanket. Straw coconut fiber blanket shall be furnished in rolled strips a minimum of 6.5 ft wide, a minimum of 80 ft long and a minimum of 0.5 lb/yd<sup>2</sup>. Straw coconut fiber blankets shall be secured in place with wire staples. Staples shall be made of 11 gauge steel wire and shall be U-shaped with 8-inch legs and 2-inch crown.
- Non-biodegradable RECPs are typically composed of polypropylene, polyethylene, nylon or other synthetic fibers. In some cases, a combination of biodegradable and synthetic fibers is used to construct the RECP. Netting used to hold these fibers together is typically non-biodegradable as well.
  - **Plastic netting** is a lightweight biaxially-oriented netting designed for securing loose mulches like straw to soil surfaces to establish vegetation. The netting is photodegradable. The netting is supplied in rolled strips, which shall be secured with U-shaped staples or stakes in accordance with manufacturers' recommendations.
  - **Plastic mesh** is an open-weave geotextile that is composed of an extruded synthetic fiber woven into a mesh with an opening size of less than 0.2 inch. It is used with revegetation or may be used to secure loose fiber such as straw to the ground. The material is supplied in rolled strips, which shall be secured to the soil with U-shaped staples or stakes in accordance with manufacturers' recommendations.
  - **Synthetic fiber with netting** is a mat that is composed of durable synthetic fibers treated to resist chemicals and ultraviolet light. The mat is a dense, three-dimensional mesh of synthetic (typically polyolefin) fibers stitched between two polypropylene nets. The mats are designed to be revegetated and provide a permanent composite system of soil, roots, and geomatrix. The material is furnished in rolled strips, which shall be secured with U-shaped staples or stakes in accordance with manufacturers' recommendations.
  - **Bonded synthetic fibers** consist of a three-dimensional geomatrix nylon (or other synthetic) matting. Typically it has more than 90% open area, which facilitates root growth. Its tough root-reinforcing system anchors vegetation and protects against hydraulic lift and shear forces created by

high volume discharges. It can be installed over prepared soil, followed by seeding into the mat. Once vegetated, it becomes an invisible composite system of soil, roots, and geomatrix. The material is furnished in rolled strips that shall be secured with U-shaped staples or stakes in accordance with manufacturers' recommendations.

- **Combination synthetic and biodegradable RECPs** consist of biodegradable fibers, such as wood fiber or coconut fiber, with a heavy polypropylene net stitched to the top and a high-strength continuous-filament geomatrix or net stitched to the bottom. The material is designed to enhance revegetation. The material is furnished in rolled strips, which shall be secured with U-shaped staples or stakes in accordance with manufacturers' recommendations.

## ***Site Preparation***

- Proper site preparation is essential to ensure complete contact of the blanket or matting with the soil.
- Grade and shape the area of installation.
- Remove all rocks, clods, vegetation or other obstructions so that the installed blankets or mats will have complete, direct contact with the soil.
- Prepare seedbed by loosening 2 in. to 3 in. of topsoil.

## ***Seeding***

Seed the area before blanket installation for erosion control and revegetation. Seeding after mat installation is often specified for turf reinforcement application. When seeding prior to blanket installation, all check slots and other areas disturbed during installation must be re-seeded. Where soil filling is specified, seed the matting and the entire disturbed area after installation and prior to filling the mat with soil.

## ***Anchoring***

- U-shaped wire staples, metal geotextile stake pins or triangular wooden stakes can be used to anchor mats and blankets to the ground surface.
- Staples shall be made of 11 gauge steel wire and shall be U-shaped with 8-inch legs and 2-inch crown.
- Metal stake pins shall be 0.188 in. diameter steel with a 1.5 in. steel washer at the head of the pin.
- Wire staples and metal stakes shall be driven flush to the soil surface.
- All anchors shall be 6 in. to 18 in. long and have sufficient ground penetration to resist pullout. Longer anchors may be required for loose soils.

## ***Installation on Slopes***

Installation shall be in accordance with the manufacturer's recommendations. In general, these will be as follows:

- Begin at the top of the slope and anchor the blanket in a 6 in. deep by 6 in. wide trench. Backfill the trench and tamp earth firmly.
- Unroll the blanket down slope in the direction of water flow.
- Overlap the edges of adjacent parallel rolls 2 in. to 3 in. and staple every 3 ft.
- When blankets must be spliced, place blankets end over end (shingle style) with 6 in. overlap. Staple through overlapped area, approximately 12 in. apart.
- Lay blankets loosely and maintain direct contact with the soil. Do not stretch.
- Staple blankets sufficiently to anchor blanket and maintain contact with the soil. Staples shall be placed down the center and staggered with the staples placed along the edges. Steep slopes, 1:1 (V:H) to 1:2 (V:H), require a minimum of 2 staples/yd<sup>2</sup>. Moderate slopes, 1:2 (V:H) to 1:3 (V:H), require a minimum of 1½ staples/yd<sup>2</sup>, placing 1 staple/yd on centers. Gentle slopes require a minimum of 1 staple/yd<sup>2</sup>.

## ***Installation in Channels***

Installation shall be in accordance with the manufacturer's recommendations. In general, these will be as follows:

- Dig initial anchor trench 12 in. deep and 6 in. wide across the channel at the lower end of the project area.
- Excavate intermittent check slots, 6 in. deep and 6 in. wide across the channel at 25 ft to 30 ft intervals along the channels.
- Cut longitudinal channel anchor slots 4 in. deep and 4 in. wide along each side of the installation to bury edges of matting, whenever possible extend matting 2 in. to 3 in. above the crest of the channel side slopes.
- Beginning at the downstream end and in the center of the channel, place the initial end of the first roll in the anchor trench and secure with fastening devices at 12 in. intervals. Note: matting will initially be upside down in anchor trench.
- In the same manner, position adjacent rolls in anchor trench, overlapping the preceding roll a minimum of 3 in.
- Secure these initial ends of mats with anchors at 12 in. intervals, backfill and compact soil.

- Unroll center strip of matting upstream. Stop at next check slot or terminal anchor trench. Unroll adjacent mats upstream in similar fashion, maintaining a 3 in. overlap.
- Fold and secure all rolls of matting snugly into all transverse check slots. Lay mat in the bottom of the slot then fold back against it. Anchor through both layers of mat at 12 in. intervals, then backfill and compact soil. Continue rolling all mat widths upstream to the next check slot or terminal anchor trench.
- Alternate method for non-critical installations: Place two rows of anchors on 6 in. centers at 25 ft to 30 ft intervals in lieu of excavated check slots.
- Shingle-lap spliced ends by a minimum of 12 in. apart on 12 in. intervals.
- Place edges of outside mats in previously excavated longitudinal slots, anchor using prescribed staple pattern, backfill and compact soil.
- Anchor, fill and compact upstream end of mat in a 12 in. by 6 in. terminal trench.
- Secure mat to ground surface using U-shaped wire staples, geotextile pins, or wooden stakes.
- Seed and fill turf reinforcement matting with soil, if specified.

### ***Soil Filling (if specified for turf reinforcement)***

- Always consult the manufacturer's recommendations for installation.
- Do not drive tracked or heavy equipment over mat.
- Avoid any traffic over matting if loose or wet soil conditions exist.
- Use shovels, rakes or brooms for fine grading and touch up.
- Smooth out soil filling, just exposing top netting of mat.

### ***Temporary Soil Stabilization Removal***

- When no longer required for the work, temporary soil stabilization shall become the property of the Contractor. Temporary soil stabilization removed from the project site shall be disposed of in conformance with all applicable laws and regulations. If approved by the Engineer, the contractor may leave the temporary soil stabilizer in place.

# Geotextiles, Mats, Plastic Covers and Erosion Control Blankets

---

SS-7

**Maintenance and Inspection** Areas treated with temporary soil stabilization shall be maintained to provide adequate erosion control. Temporary soil stabilization shall be reapplied or replaced on exposed soils when area becomes exposed or exhibits visible erosion.

- Inspect all slopes and areas stabilized with geotextiles, mats, plastic covers, or erosion control blankets weekly and before and after every rainfall events. During extended rainfall events, inspect all slopes and areas stabilized with geotextiles, mats, plastic covers, or erosion control blankets at least once every 24 hours.
- Any failures shall be repaired immediately. If washout or breakage occurs, the material shall be re-installed after repairing the damage to the slope.



# Geotextiles, Mats, Plastic Covers and Erosion Control Blankets

SS-7

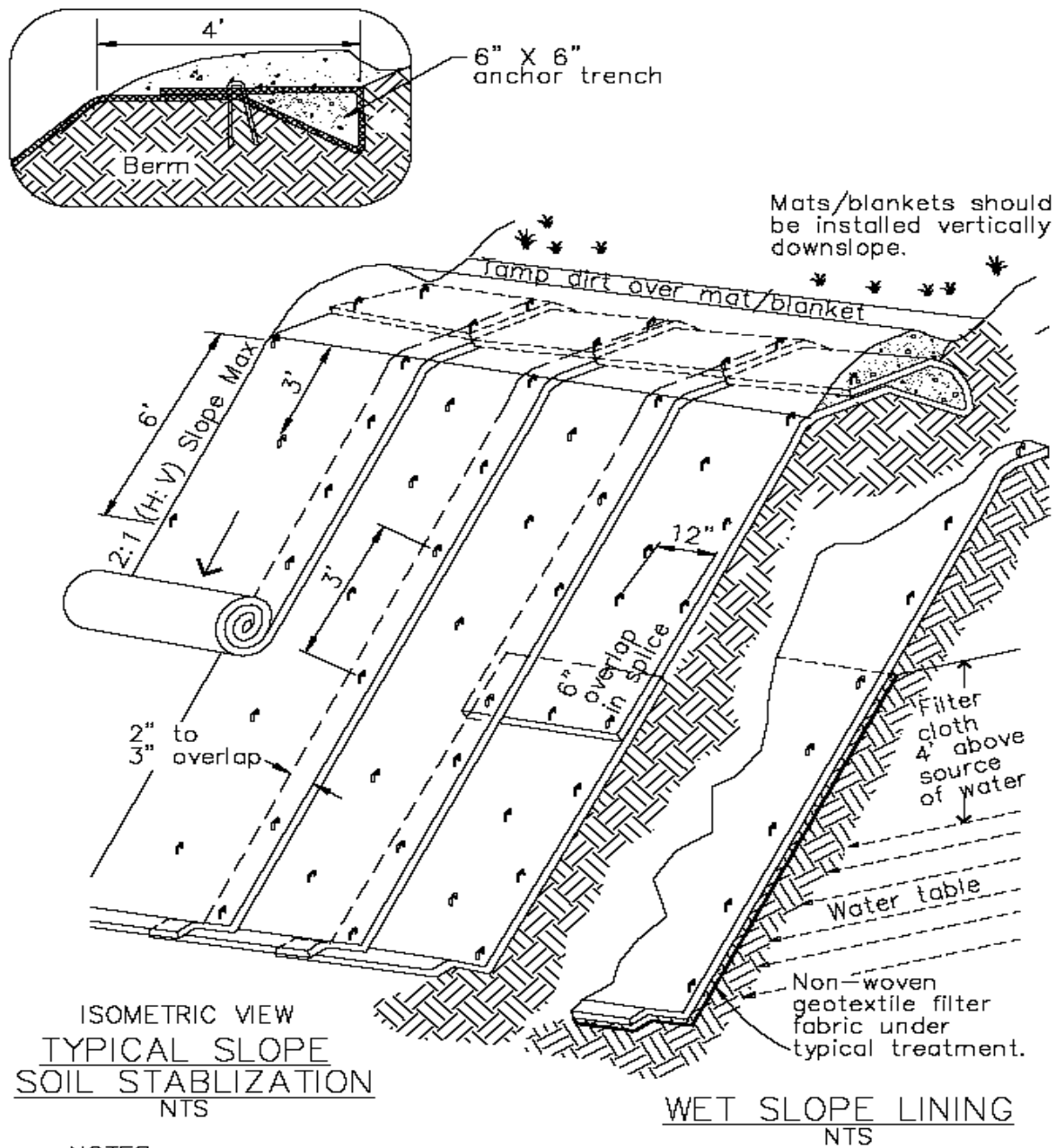

NOTES:

1. Slope surface shall be free of rocks, clods, sticks and grass. Mats/blankets shall have good soil contact.
2. Lay blankets loosely and stake or staple to maintain direct contact with the soil. Do not stretch.
3. Install per manufacturer's recommendations

TYPICAL INSTALLATION DETAIL



# Geotextiles, Mats, Plastic Covers and Erosion Control Blankets

SS-7

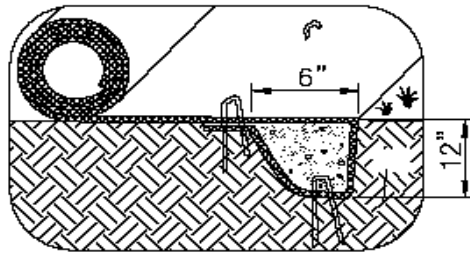

INITIAL CHANNEL ANCHOR TRENCH  
NTS

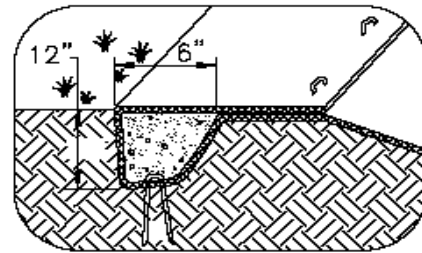

TERMINAL SLOPE AND CHANNEL  
ANCHOR TRENCH  
NTS

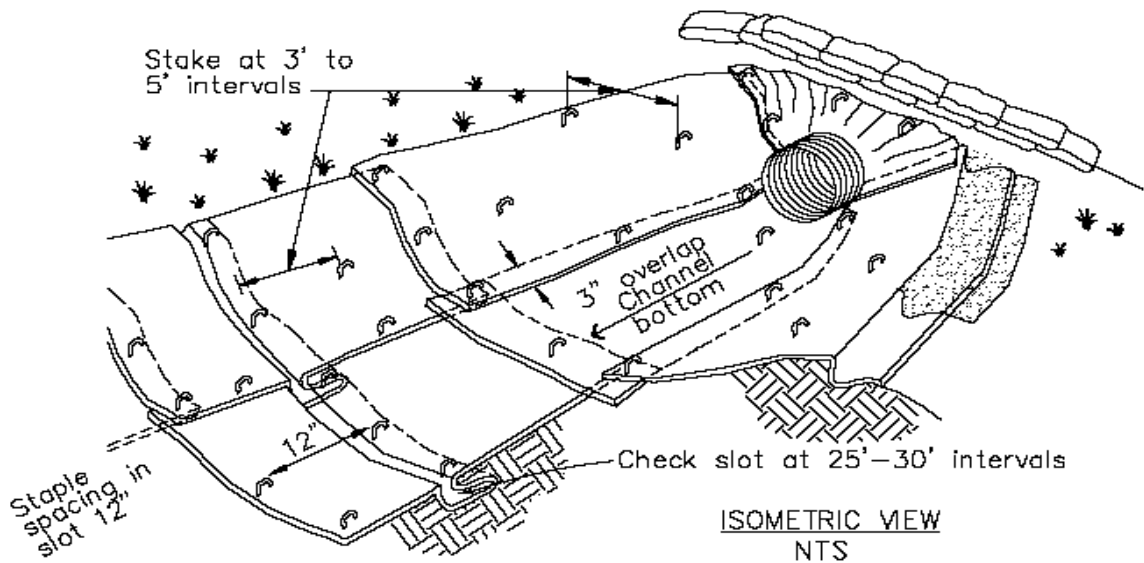

ISOMETRIC VIEW  
NTS

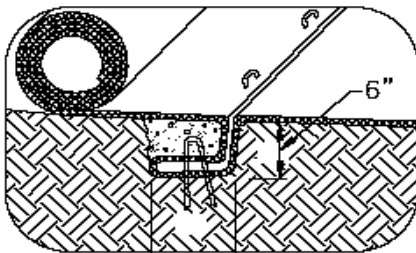

INTERMITTENT CHECK SLOT  
NTS

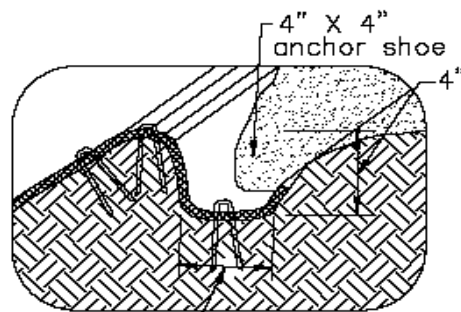

LONGITUDINAL ANCHOR TRENCH  
NTS

NOTES:

1. Check slots to be constructed per manufacturers specifications.
2. Staking or stapling layout per manufacturers specifications.
3. Install per manufacturer's recommendations

TYPICAL INSTALLATION DETAIL







Standard Symbol

- BMP Objectives**
- Soil Stabilization
  - Sediment Control
  - Tracking Control
  - Wind Erosion Control
  - Non-Storm Water Management
  - Materials and Waste Management

**Definition and Purpose** Wood mulching consists of applying a mixture of shredded wood mulch, bark or compost. Wood mulch is mostly applicable to landscape projects.

The primary function of wood mulching is to reduce erosion by protecting bare soil from rainfall impact, increasing infiltration, and reducing runoff.

**Appropriate Applications** Wood mulching is considered a temporary soil stabilization (erosion control) alternative in the following situations:

- As a stand-alone temporary surface cover on disturbed areas until soils can be prepared for revegetation and permanent vegetative cover can be established.
- As short term, non-vegetative ground cover on slopes to reduce rainfall impact, decrease the velocity of sheet flow, settle out sediment and reduce wind erosion.

- Limitations**
- Shredded wood does not withstand concentrated flows and is prone to sheet erosion.
  - Green material has the potential for the presence of unwanted weeds and other plant materials. Delivery system is primarily by manual labor, although pneumatic application equipment is available.

**Standards and Specifications** ***Mulch Selection***

There are many types of mulches, and selection of the appropriate type shall be based on the type of application and site conditions. Prior to use of wood mulches, there shall be concurrence with the Engineer since some mulch use on construction projects may not be compatible with planned or future projects. Selection of wood mulches by the Contractor must be approved by the Engineer.

## ***Application Procedures***

Prior to application, after existing vegetation has been removed, roughen embankment and fill areas by rolling with a punching-type roller or by track walking. The construction-application procedures for mulches vary significantly depending upon the type of mulching method specified. Two (2) methods are highlighted here:

- **Green Material:** This type of mulch is produced by recycling vegetation trimmings such as grass, shredded shrubs and trees. Methods of application are generally by hand, although pneumatic methods are available. Mulch shall be composted to kill weed seeds.
  - It can be used as a temporary ground cover with or without seeding.
  - The green material shall be evenly distributed on site to a depth of not more than 2 in.
- **Shredded Wood:** Suitable for ground cover in ornamental or revegetated plantings.
  - Shredded wood/bark is conditionally suitable; see note under limitations.
  - Shall be distributed by hand (although pneumatic methods may be available).
  - The mulch shall be evenly distributed across the soil surface to a depth of 2 in. to 3 in.
- Avoid mulch placement onto the traveled way, sidewalks, lined drainage channels, sound walls, and existing vegetation.
- All material must be removed before re-starting work on the slopes.

## **Maintenance and Inspection**

- Inspect areas stabilized with wood mulch weekly and before and after every rainfall events. During extended rainfall events, inspect areas stabilized with wood mulch at least once every 24 hours.
- Wood mulch needs to last long enough to achieve erosion-control objectives. If the mulch is applied as a stand-alone erosion control method over disturbed areas (without seed), it shall last the length of time the site will remain barren or until final re-grading and revegetation.
- Where vegetation is not the ultimate cover, such as ornamental and landscape applications of bark or wood chips, inspection and maintenance shall focus on longevity and integrity of the mulch.

# Earth Dikes/Drainage Swales and Lined Ditches

SS-9

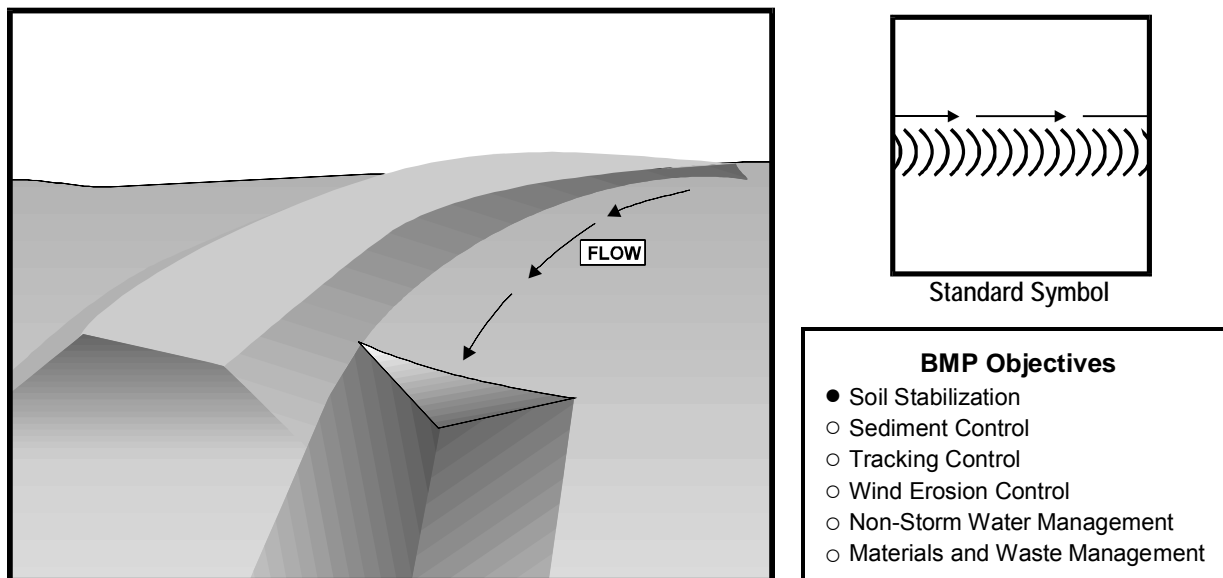

**Definition and Purpose** These are structures that intercept, divert and convey surface run-on, generally sheet flow, to prevent erosion.

## Appropriate Applications

- Earth dikes/drainage swales and lined ditches may be used to:
  - Convey surface runoff down sloping land.
  - Intercept and divert runoff to avoid sheet flow over sloped surfaces.
  - Divert and direct runoff towards a stabilized watercourse, drainage pipe or channel. Surface water diversion in streambeds or channels shall be in compliance with the contract Special Provisions and regulatory permits.
  - Intercept runoff from paved surfaces.
- Earth dikes/drainage swales and lined ditches also may be used:
  - Below steep grades where runoff begins to concentrate.
  - Along roadways and facility improvements subject to flood drainage.
  - At the top of slopes to divert run-on from adjacent or undisturbed slopes.
  - At bottom and mid-slope locations to intercept sheet flow and convey concentrated flows.
- This BMP may be implemented on a project-by-project basis with other BMPs when determined necessary and feasible by the Engineer.

# Earth Dikes/Drainage Swales and Lined Ditches

---

SS-9

- Limitations**
- Earth dikes/drainage swales and lined ditches are not suitable as sediment trapping devices.
  - May be necessary to use other soil stabilization and sediment controls, such as check dams, plastics, and blankets, to prevent scour and erosion in newly graded dikes, swales and ditches.
- Standards and Specifications**
- Care must be applied to correctly size and locate earth dikes, drainage swales and lined ditches. Excessively steep, unlined dikes and swales are subject to erosion and gully formation.
  - Conveyances shall be stabilized.
  - Use a lined ditch for high flow velocities.
  - Select flow velocity based on careful evaluation of the risks due to erosion of the measure, soil types, over topping, flow backups, washout, and drainage flow patterns for each project site.
  - Compact any fills to prevent unequal settlement.
  - Do not divert runoff from the construction project onto other property.
  - When possible, install and utilize permanent dikes, swales and ditches early in the construction process.
  - Provide stabilized outlets. Refer to SS-10, “Outlet Protection/Velocity/Dissipation Devices.”
- Maintenance and Inspections**
- Inspect earth dikes, drainage swales and lined ditches weekly and before and after every rainfall events. During extended rainfall events, inspect earth dikes, drainage swales and lined ditches at least once every 24 hours.
  - Inspect ditches and berms for washouts. Replace lost riprap, damaged linings or soil stabilizers as needed.
  - Inspect channel linings, embankments, and beds of ditches and berms for erosion and accumulation of debris and sediment. Remove debris and sediment, and repair linings and embankments as needed or as directed by the Engineer.
  - Temporary conveyances shall be completely removed as soon as the surrounding drainage area has been stabilized, or at the completion of construction.



# Earth Dikes/Drainage Swales and Lined Ditches

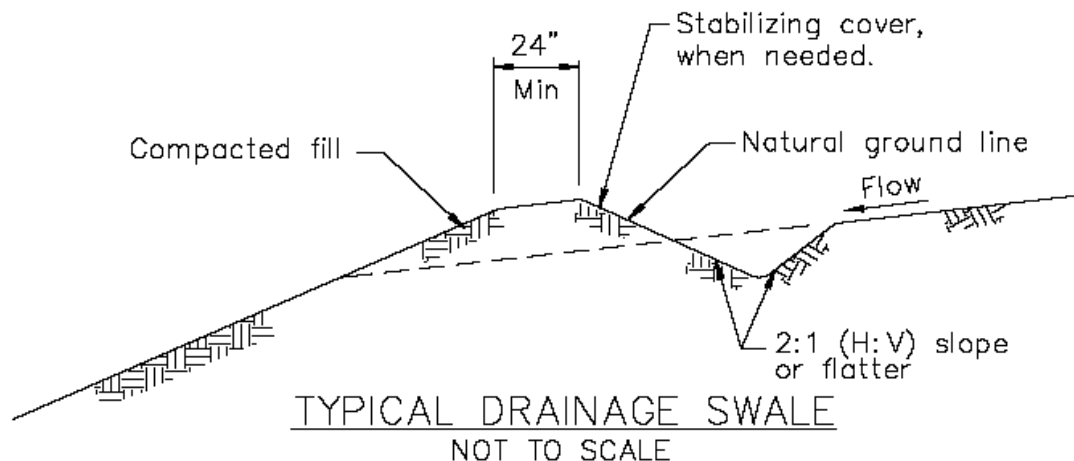

NOTES:

1. Stabilize inlet, outlets and slopes.
2. Properly compact the subgrade.

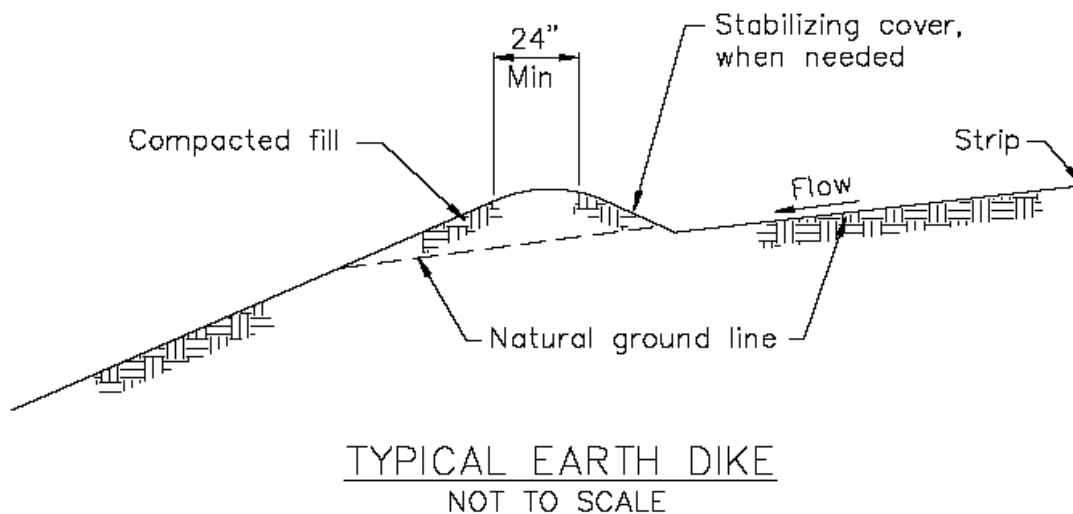

(This page left intentionally blank)

# Outlet Protection/Velocity Dissipation Devices

SS-10

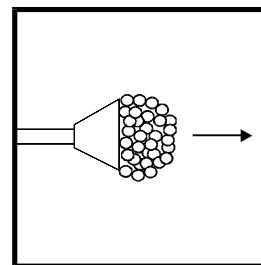
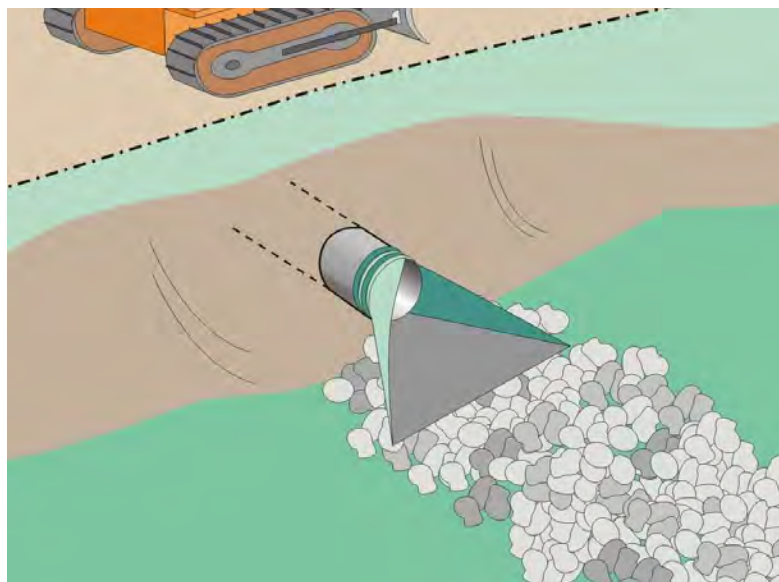

Standard Symbol

### BMP Objectives

- Soil Stabilization
- Sediment Control
- Tracking Control
- Wind Erosion Control
- Non-Storm Water Management
- Materials and Waste Management

**Definition and Purpose** Outlet protection and velocity dissipation devices are placed at pipe outlets to prevent scour and reduce the velocity and/or energy of storm water flows.

- Appropriate Applications**
- These devices may be used at the following locations:
    - Outlets of pipes, drains, culverts, slope drains, diversion ditches, swales, conduits or channels.
    - Outlets located at the bottom of mild to steep slopes.
    - Points where lined conveyances discharge to unlined conveyances.

**Limitations** The use of outlet protection and velocity dissipation devices in streambeds shall be in compliance with the contract Special Provisions and approved by the Engineer.

- Standards and Specifications**
- There are many types of energy dissipaters, with rock being the one that is represented in the figure on Page 3. Please note that this is only one example and the Engineer may approve other types of devices proposed by the contractor.
  - Install riprap, grouted riprap, or concrete apron at selected outlet. Riprap aprons are best suited for temporary use during construction.
  - Grouted riprap shall be approved by the Engineer prior to installation.
  - Carefully place riprap to avoid damaging the filter fabric.

# Outlet Protection/Velocity Dissipation Devices

---

SS-10

## Standards and Specifications

- For proper operation of apron:
  - Align apron with receiving stream and keep straight throughout its length. If a curve is needed to fit site conditions, place it in upper section of apron.
  - If size of apron riprap is large, protect underlying filter fabric with a gravel blanket.
- Outlets on slopes steeper than 10% shall have additional protection.
- There are many types of energy dissipaters, with rock being the one that is represented in the figure on Page 3. Please note that this is only one example and the Engineer may approve other types of devices proposed by the contractor.
- Install riprap, grouted riprap, or concrete apron at selected outlet. Riprap aprons are best suited for temporary use during construction.
- Carefully place riprap to avoid damaging the filter fabric.
- For proper operation of apron:
  - Align apron with receiving stream and keep straight throughout its length. If a curve is needed to fit site conditions, place it in upper section of apron.
  - If size of apron riprap is large, protect underlying filter fabric with a gravel blanket.
- Outlets on slopes steeper than 10% shall have additional protection.

## Maintenance and Inspection

- Inspect all outlet protection and velocity dissipation devices weekly and before and after every rainfall events. During extended rainfall events, inspect outlet protection and velocity dissipation devices at least once every 24 hours.
- Inspect apron for displacement of the riprap and/or damage to the underlying fabric. Repair fabric and replace riprap that has washed away.
- Inspect for scour beneath the riprap and around the outlet. Repair damage to slopes or underlying filter fabric immediately.
- Temporary devices shall be completely removed as soon as the surrounding drainage area has been stabilized, or at the completion of construction.





# Outlet Protection/Velocity Dissipation Devices

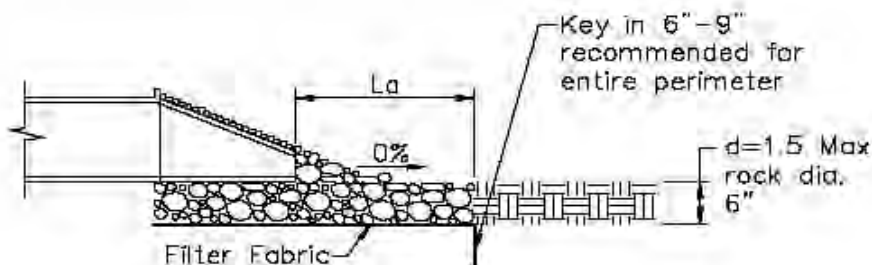
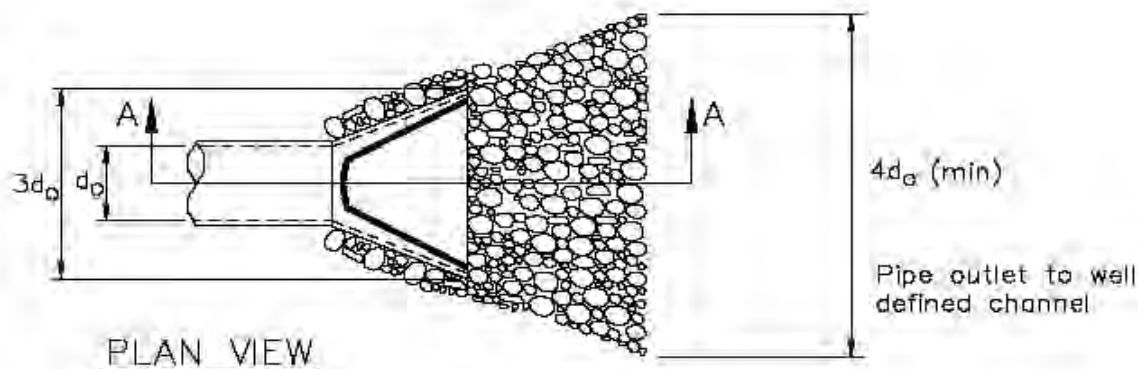

Pipe Diameter inches	Discharge ft <sup>3</sup> /s	Apron Length, La ft	Rip Rap D <sub>50</sub> Diameter Min inches
12	5	10	4
	10	13	6
18	10	10	6
	20	16	8
	30	23	12
	40	26	16
24	30	16	8
	40	26	8
	50	26	12
	60	30	16

For larger or higher flows consult a Registered Civil Engineer  
 Source: USDA - SCS



(This page left intentionally blank)

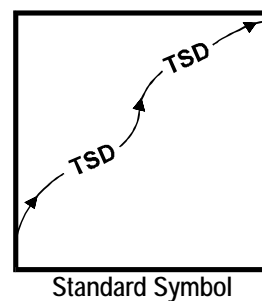
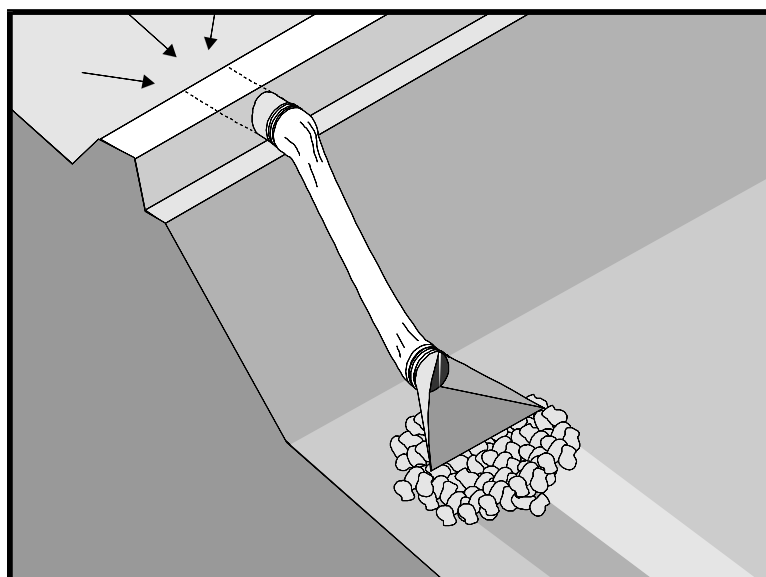

- BMP Objectives**

  - Soil Stabilization
  - Sediment Control
  - Tracking Control
  - Wind Erosion Control
  - Non-Storm Water Management
  - Materials and Waste Management

**Definition and Purpose** A slope drain is a pipe used to intercept and direct surface runoff or groundwater into a stabilized watercourse, trapping device or stabilized area. Slope drains are used with lined ditches to intercept and direct surface flow away from slope areas to protect cut or fill slopes.

- Appropriate Applications**
- Slope drains may be used on construction sites where slopes may be eroded by surface runoff.
  - Slope drains shall be implemented in conjunction with other BMPs. Slope drains result in concentrated flow that shall be dissipated at the outlet to prevent erosion.

**Limitations** ■ None identified.

- Standards and Specifications**
- When using slope drains, limit drainage area to 10 ac per pipe. For larger areas, use a rock-lined channel or a series of pipes.
  - Maximum slope should be generally limited to 1:2 (V:H), as energy dissipation below steeper slopes is difficult.
  - Direct surface runoff to slope drains with interceptor dikes. See BMP SS-8, "Earth Dikes/Drainage Swales, and Lined Ditches."
  - Slope drains can be placed on or buried underneath the slope surface.
  - Recommended materials are PVC, ABS, or comparable pipe.
  - When installing slope drains:
    - Install slope drains perpendicular to slope contours.
    - Compact soil around and under entrance, outlet, and along length of pipe.

- Securely anchor and stabilize pipe and appurtenances into soil.
- Check to ensure that pipe connections are water tight.
- Protect area around inlet with filter cloth. Protect outlet with riprap or other energy dissipation device. For high energy discharges, reinforce riprap with concrete or use reinforced concrete device.
- Protect inlet and outlet of slope drains; use standard flared end section at entrance and exit for pipe slope drains 12in. and larger.

## Maintenance and Inspection

- Inspect slope drains weekly and before and after every rainfall events. During extended rainfall events, inspect slope drains at least once every 24 hours.
- Inspect outlet for erosion and downstream scour. If eroded, repair damage and install additional energy dissipation measures. If downstream scour is occurring, it may be necessary to reduce flows being discharged into the channel unless other preventative measures are implemented.
- Inspect slope drainage for accumulations of debris and sediment.
- Remove built-up sediment from entrances, outlets, and within drains as required.
- Make sure water is not ponding onto inappropriate areas (e.g., active traffic lanes, material storage areas, etc.).



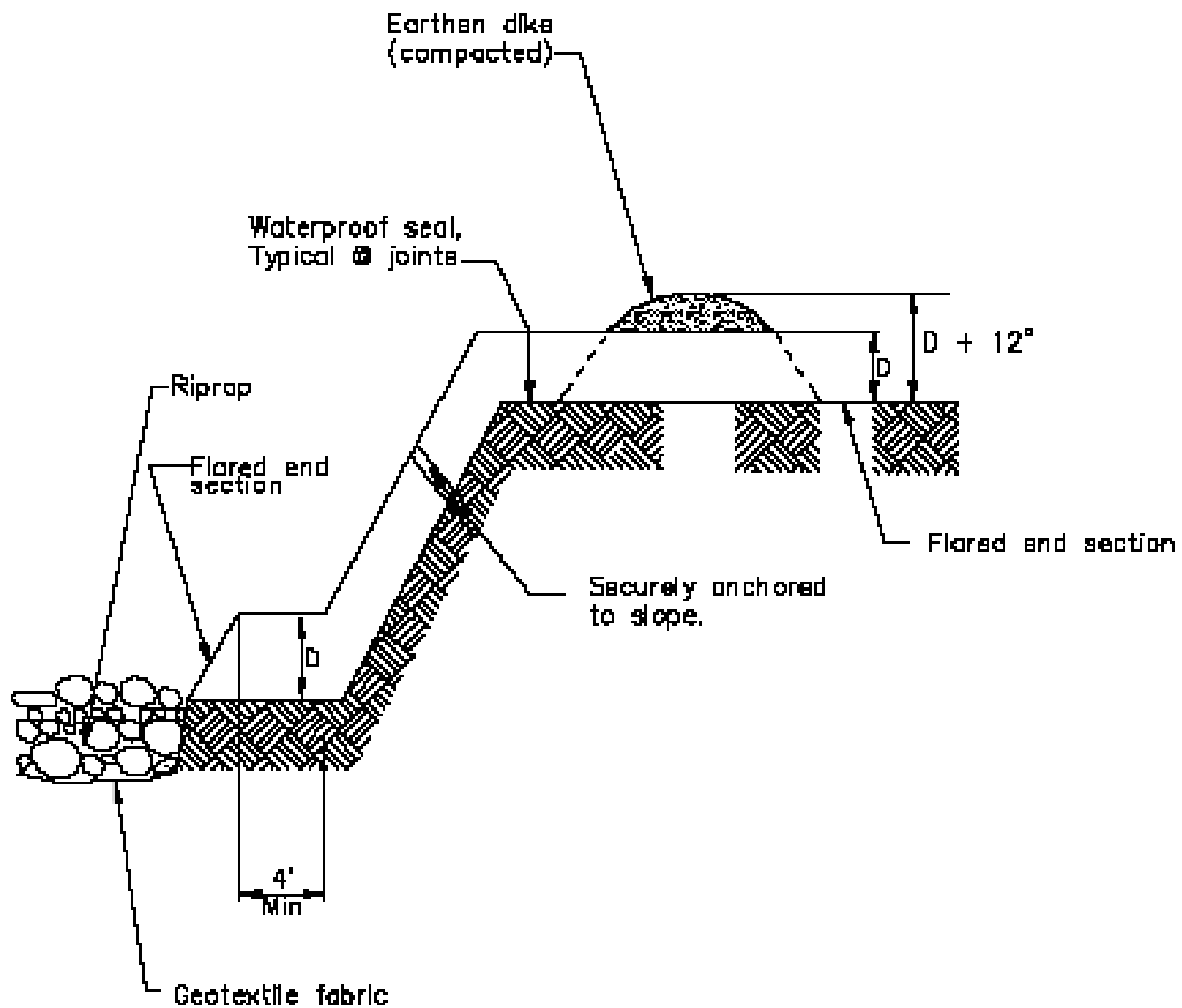

TYPICAL SLOPE DRAIN  
NOT TO SCALE

(This page left intentionally blank)

## SECTION 4

### TEMPORARY SEDIMENT CONTROL BMPs

Temporary sediment control BMPs include practices that intercept, slow, or detain the flow of storm water to allow sediment to settle and be contained on the construction site. Temporary sediment control BMPs consist of installing temporary barriers or basins placed below the toe of slopes, down gradient of areas of exposed soil, around stockpiles, and other appropriate locations along the construction site perimeter. Fiber rolls and/or gravel bag berms are required to break up slope lengths. Effective perimeter controls (i.e., silt fence, fiber rolls, gravel bag berms, or sandbag berms) shall be established and maintained. Temporary sediment control practices include the BMPs shown on Table 4-1.

<b>Table 4-1 Temporary Sediment Control BMPs</b>	
<b>ID</b>	<b>BMP Name</b>
SC-1	Silt Fence
SC-2	Sediment/Desilting Basin
SC-3	Sediment Trap
SC-4	Check Dam
SC-5	Fiber Rolls
SC-6	Gravel Bag Berm
SC-7	Street Sweeping and Vacuuming
SC-8	Sandbag Barrier
SC-9	Straw Bale Barrier
SC-10	Storm Drain Inlet Protection

(This page left intentionally blank)



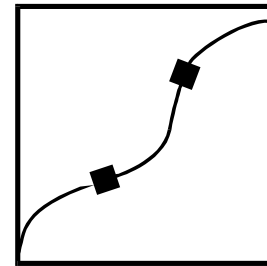
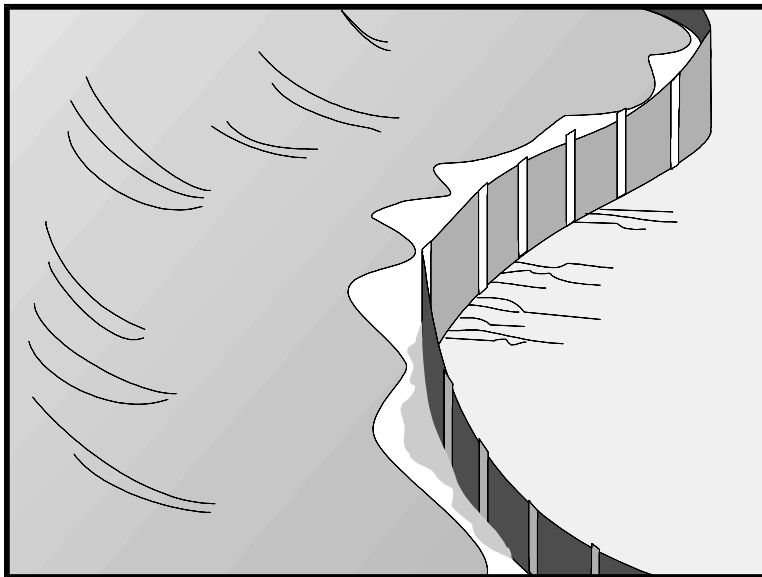

**Standard Symbol**

**BMP Objectives**

- Soil Stabilization
- Sediment Control
- Tracking Control
- Wind Erosion Control
- Non-Storm Water Management
- Materials and Waste Management

**Definition and Purpose** A silt fence is a temporary linear sediment barrier of permeable fabric designed to intercept and slow the flow of sediment-laden sheet flow runoff. Silt fences allow sediment to settle from runoff before water leaves the construction site.

- Appropriate Applications** Silt fences are placed:
- Below the toe of exposed and erodible slopes.
  - Down-slope of exposed soil areas.
  - Around temporary stockpiles.
  - Along streams and channels.
  - Along the perimeter of a project.

- Limitations**
- Shall not be used below slopes subject to creep, slumping, or landslides.
  - Shall not be used in streams, channels, drain inlets, or anywhere flow is concentrated.
  - Shall not be used to divert flow. Silt fences shall not be used in concentrated flow areas.

- Standards and Specifications** **Design and Layout**
- The maximum length of slope draining to any point along the silt fence shall be 200 ft or less.
  - The slope of area draining to silt fence shall be less than 1:1 (V:H).
  - Shall not use as mid-slope protection on slopes greater than 1:4 (V:H).

- Limit silt fence installation to locations suitable for temporary ponding and deposition of sediment.
- Fabric life span is generally limited. Longer periods may require fabric replacement.
- Lay out shall be in accordance with Pages 5 and 6 of this BMP.
- For slopes steeper than 1:2 (V:H) and that contain a high number of rocks or large dirt clods that tend to dislodge, it may be necessary to install additional protection immediately adjacent to the bottom of the slope, prior to installing silt fence. Additional protection may be a chain link fence or a cable fence.
- For slopes adjacent to water bodies or Environmentally Sensitive Areas (ESAs), or as directed by the engineer, additional temporary soil stabilization BMPs shall be used.

## Materials

- Silt fence fabric shall be woven polypropylene with a minimum width of 36 inches and a minimum tensile strength of 100 lb force. The fabric shall conform to the requirements in ASTM designation D4632 and shall have an integral reinforcement layer. The reinforcement layer shall be a polypropylene, or equivalent, net provided by the manufacturer. The permittivity of the fabric shall be between 0.1 sec-1 and 0.15 sec-1 in conformance with the requirements in ASTM designation D4491. Contractor shall submit certificate of compliance with these specifications.
- Wood stakes shall be commercial quality lumber of the size and shape shown on the plans. Each stake shall be free from decay, splits or cracks longer than the thickness of the stake or other defects that would weaken the stakes and cause the stakes to be structurally unsuitable.
- Bar reinforcement may be used in lieu of wood stakes. The bars shall be equal to a number four (4) or greater. End protection shall be provided for any exposed bar reinforcement.
- Staples used to fasten the fence fabric to the stakes shall be not less than 1.75 inches long and shall be fabricated from 15 gauge or heavier wire. The wire used to fasten the tops of the stakes together when joining two sections of fence shall be 9 gauge or heavier wire.

## Installation

- Silt fences shall be used in conjunction with soil stabilization source controls up slope to provide effective erosion and sediment control.
- Bottom of the silt fence shall be keyed or trenched -in a minimum of 12 inches. Trenches shall not be excavated wider and deeper than necessary for proper installation of the temporary linear sediment barriers.

- Excavation of the trenches shall be performed immediately before installation of the temporary linear sediment barriers.
- Construct silt fences with a set-back of at least 3 feet from the toe of a slope. Where a silt fence is determined to be not practical due to specific site conditions, the silt fence may be constructed at the toe of the slope, but shall be constructed as far from the toe of the slope as practical.
- Construct the length of each reach so that the change in base elevation along the reach does not exceed 1/3 the height of the barrier.
- Cross barriers shall be a minimum of 1/3 and a maximum of 1/2 the height of the linear barrier.

## Maintenance and Inspection

- Ensure that perimeter controls are maintained and protected from activities that reduce their effectiveness.
- Repair undercut silt fences. Repair or replace split, torn, slumping, or weathered fabric.
- Inspect all silt fences a minimum of weekly and before and after every rainfall events. During extended rainfall events, inspect inlet protection devices at least once every 24 hours. Perform necessary maintenance, or maintenance required by the Engineer.
- Maintain silt fences to provide an adequate sediment holding capacity. Sediment shall be removed when the sediment accumulation reaches one-third (1/3) of the barrier height. Removed sediment shall be incorporated in the project at locations designated by the Engineer or disposed of outside the right-of-way in conformance with all applicable laws and regulations.
- Silt fences that are damaged and become unsuitable for the intended purpose, as determined by the Engineer, shall be removed from the site of work, disposed of outside the project right-of-way in conformance with all applicable laws and regulations, and replaced with new silt fence barriers.
- Remove silt fence when no longer needed or as required by the Engineer. Fill and compact post holes and anchorage trench, remove sediment accumulation, grade fence alignment to blend with adjacent ground and stabilized disturbed soil areas.

# Silt Fence

**SC-1**

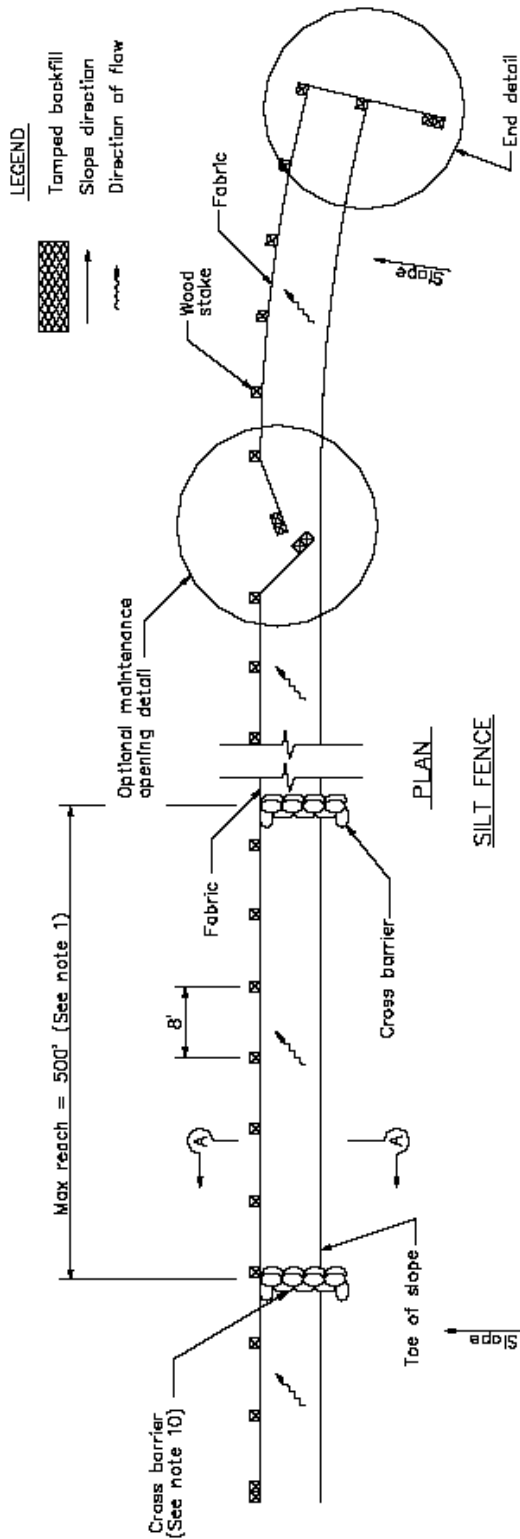

**NOTES**

1. Construct the length of each reach so that the change in base elevation along the reach does not exceed 1/3 the height of the linear barrier, in no case shall the reach length exceed 500'.
2. The last 6'-0" of fence shall be turned up slope.
3. Stake dimensions are nominal.
4. Dimension may vary to fit field condition.
5. Stakes shall be spaced at 6'-0" maximum and shall be positioned on downstream side of fence.
6. Stakes to overlap and fence fabric to fold around each stake one full turn. Secure fabric to stake with 4 staples.
7. Stakes shall be driven tightly together to prevent potential flow-through of sediment at joint. The tops of stakes shall be secured with wire.
8. Far end stake, fence fabric shall be folded around stakes one full turn and secured with 4 staples.
9. Minimum 4 staples per stake. Dimensions shown are typical.
10. Cross barriers shall be a minimum of 1/3 and a maximum of 1/2 the height of the linear barrier.
11. Maintenance openings shall be constructed in a manner to ensure sediment remains behind silt fence.
12. Joining sections shall not be placed at sump locations.
13. Sandbag rows and layers shall be offset to eliminate gaps.

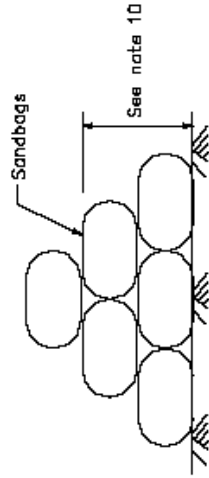
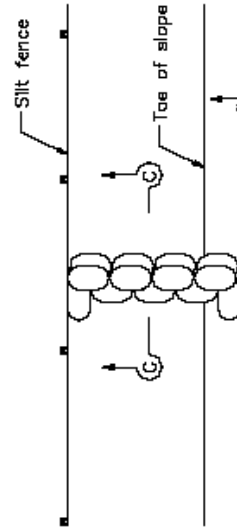

# Silt Fence

**SC-1**

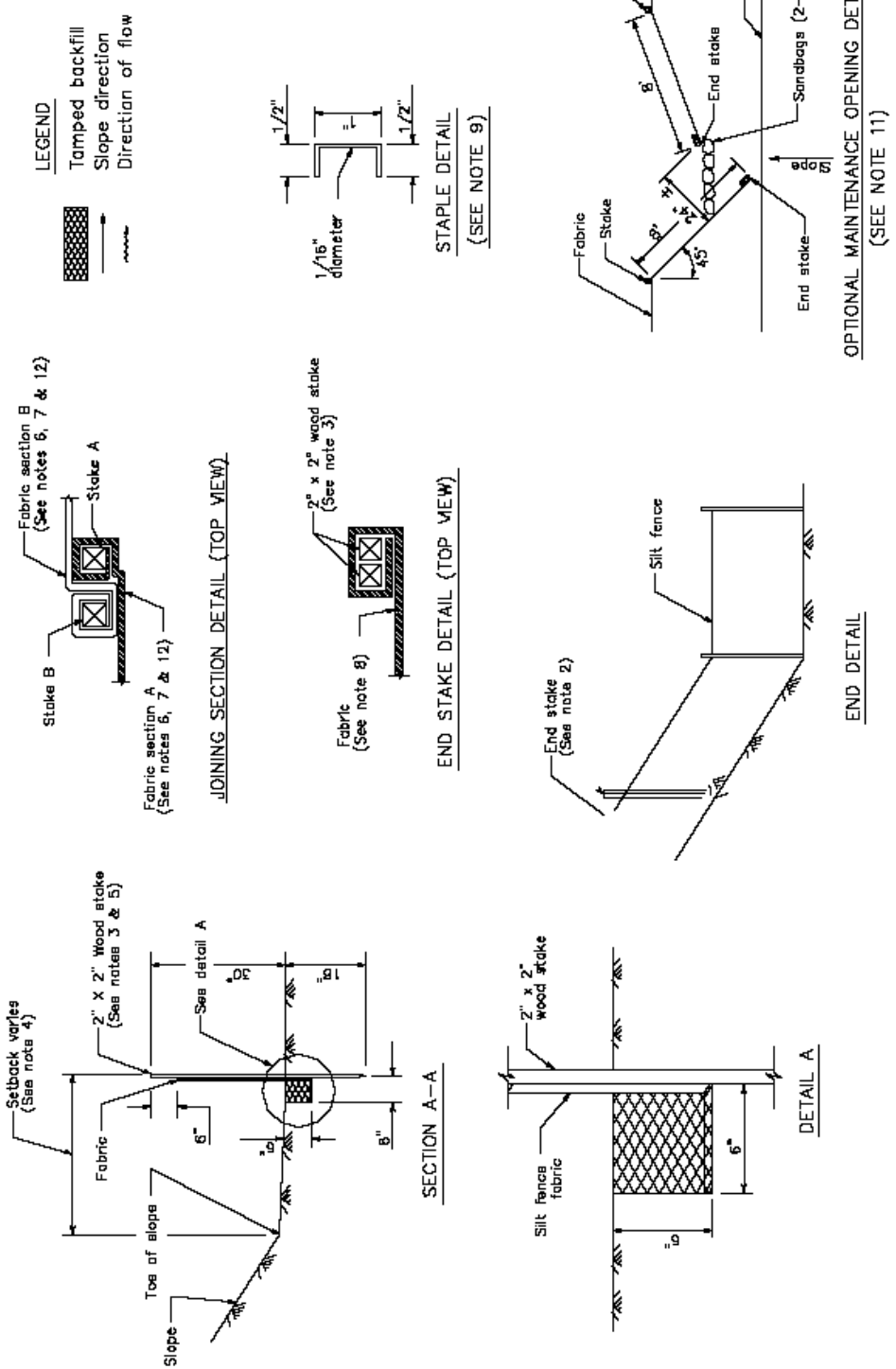

(This page left intentionally blank)

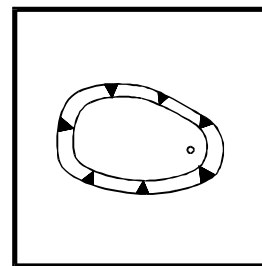
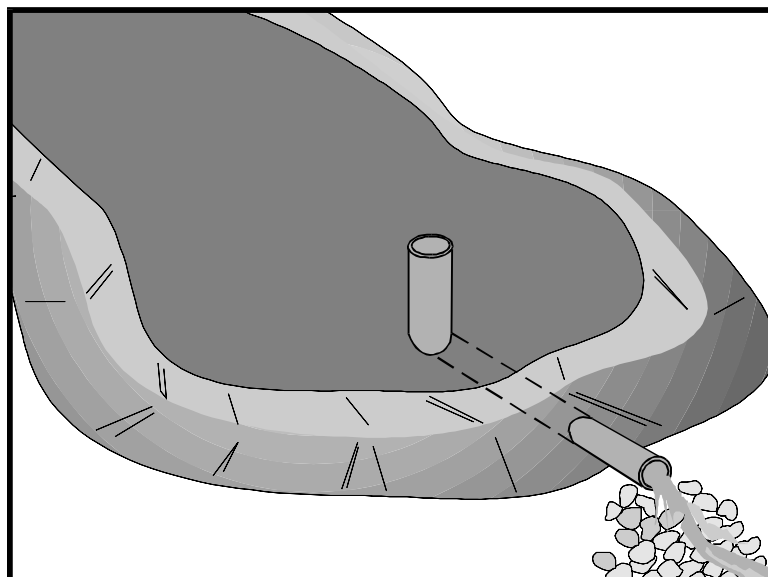

Standard Symbol

- BMP Objectives**

  - Soil Stabilization
  - Sediment Control
  - Tracking Control
  - Wind Erosion Control
  - Non-Storm Water Management
  - Materials and Waste Management

**Definition and Purpose** A sediment/desilting basin is a temporary basin formed by excavating and/or constructing an embankment so that sediment-laden runoff is temporarily detained under still conditions, allowing sediment to settle out before the runoff is discharged (refer to Figures 1 and 2).

**Appropriate Applications** As required by the Construction General Permit (NPDES No. CAS000002, Order 2009-0009-DWQ), sediment basins shall be designed at a minimum to the method provided in CASQA’s Construction BMP Guidance Handbook. This BMP is consistent with the CASQA handbook. This BMP may be implemented on a project-by-project basis with other BMPs when determined necessary and feasible by the Engineer.

Sediment/Desilting Basins shall be used:

- Where sediment-laden water may enter the drainage system or watercourses.
- At outlets of disturbed soil areas with areas between 5 ac and 10 ac.

- Limitations**
- Alternative BMPs must be thoroughly investigated for erosion control before selecting temporary desilting basins.
  - Requires large surface areas to permit settling of sediment. Size may be limited by availability of space on the construction site.
  - Not appropriate for drainage areas greater than 75 ac.
  - For safety reasons, basins shall have protective fencing.
  - Not allowed for dewatering or groundwater.

- Standards and Specifications**
- Limit the contributing area to the sediment/desilting basin to only the runoff from the disturbed soil areas. Use temporary concentrated flow conveyance controls to divert runoff from undisturbed areas away from the sediment/desilting basin.
  - Sediment/desilting basin shall be designed by a professional Engineer registered with the State of California. The Design details shall be included in the SWPPP or SWPPP amendment or approved by the Engineer prior to construction.
  - The design shall include maintenance requirements, including sediment and vegetation removal, to ensure continuous function of the trap outlet and bypass structures.

### ***Sediment Basin***

- Sediment basins shall, at a minimum, be designed as follows:
  - Option 1: Sediment basin(s) shall be designed using the standard equation:

$$As=1.2Q/Vs \quad (\text{Eq. 1})$$

Where:

$As$  = Minimum surface area for trapping soil particles of a certain size.

$Vs$  = Settling velocity of the design particle size chosen ( $Vs = 0.00028$  ft/s for a design particle size of 0.01 mm at 68 °F)

1.2 = Factor of safety recommended by USEPA to account for the reduction in basin efficiency caused due to turbulence and other non ideal conditions.

$$Q = C I A \quad (\text{Eq. 2})$$

Where:

$Q$  = Discharge rate measured in cubic feet per second

$C$  = Runoff coefficient (unit less)

$I$  = Precipitation intensity for the 10-year, 6-hour rain event (in/hr)

$A$  = Area draining into the sediment basin in acres.

The design particle size shall be the smallest soil grain size determined by wet sieve analysis, or the fine silt sized (0.01mm [or 0.004 in.]) particle, and the  $Vs$  used shall be 100 percent of the calculated settling velocity.



The basin length is determined by measuring the distance between the inlet and the outlet. If the outlet structure will be used to control the flow, the length shall be more than twice the dimension as the width. If the topography does not allow for this configuration, baffles shall be used to meet the ratio. If the basin length will be used to control flow, the length shall be designed to capture 100% of the design particle size. The depth shall not be less than 3 ft nor greater than 5 ft for safety reasons and for maximum efficiency (2 ft of sediment storage, 2 ft of capacity). The basin(s) shall be located on the site where it can be maintained on a year-round basis and shall be maintained on a schedule to retain the 2 ft of capacity.

OR

- Option 2: Pursuant to local ordinance for sediment basin design and maintenance, provided that the design efficiency is as protective or more protective of water quality than Option 1.

OR

- Option 3: The use of an equivalent surface area design or equation, provided that the design efficiency is as protective or more protective of water quality than Option 1.

In order to design a sediment basin properly, the site constraints, soil particle size distribution, drainage area, and local hydrology shall be considered.

### **Typical Hydrologic Design Methodology**

Evaluate the site constraints and assess the drainage area for the sediment basin. Consider on- and off-site flows as well as changes in drainage areas associated with construction. To minimize additional construction during the course of the project, identify and use the maximum drainage area when calculating the basin dimensions.

The Los Angeles County Department of Public Works, Hydrology Manual, January 2006 (<http://dpw.lacounty.gov/wrd/publication/engineering/2006>) Hydrology Manual shall be used to obtain the needed rainfall intensity.

Calculate the surface area required for the sediment basin using Equation 1. Discharge is estimated for a 10-year 6-hour event using the rational method procedure.  $V_s$  is estimated using Stokes Law (Eq. 3)

$$V_s = 2.81 d^2 \text{ (Eq. 3)}$$

Where:

$V_s$  = Settling velocity in feet per second at 68 °F.

$d$  = diameter of sediment particle in millimeters (smallest soil grain particle size determined by wet sieve analysis or fine silt (0.01 mm [or 00.0004 in.])).

- The basin outlet design requires an iterative trial and error approach that considers the maximum water surface elevation, elevation versus volume relationship, elevation versus discharge relationship, and the estimated inflow

hydrograph. To adequately design the basin to settle sediment, the outlet configuration and associated outflow rates shall be estimated. There are numerous methodologies:

- Outlet design typically includes multiple horizontal rows of orifices (3 or more) with at least 2 orifices per row (see figures 1 and 2).
- Select the appropriate orifice diameter and number of perforations per row with the objective of minimizing the number of rows while maximizing the detention time. Each outlet should have more than one orifice
- The diameter of each orifice is typically a maximum of 3-4 inches and a minimum of 0.25 -0.5 inches.
- If a rectangular orifice is used, it is recommended to have a minimum height of 0.5 inches and a maximum height of 6 inches.
- Rows are typically spaced at three times the diameter center to center vertically with a minimum distance of 4 inches on center and a maximum distance of 1 foot on center.
- Each row is calculated separately for outflow rate using the flow through a single orifice and multiplying by the number of orifices in that row. Repeat this step for each row and sum the rows. The total outflow rate is then compared to the detention time within the basin.

Flow through a single orifice can be estimated using the following equation (Eq. 4):

$$Q = BC' A(2gH)^{0.5} \text{ (Eq. 4)}$$

Where:

Q = Discharge in ft<sup>3</sup>/s

C' = Orifice coefficient (unit less)

A = area of the orifice (ft<sup>2</sup>)

g = acceleration due to gravity (ft<sup>3</sup>/s)

H = head above the orifice (ft)

B = anticipated Blockage or clogging factor (unitless), dependent on anticipated sediment and debris load, trash rack configuration, etc., so the value is dependent on professional judgment and/or local requirements (B is never greater than 1 and a value of 0.5 is generally used).

- For the orifice coefficient (C') the value of 0.6 is most often recommended and used, or  
C' = 0.66 for thin materials- where the thickness of the material (used to form the orifice) is equal to or less than the diameter of the orifice, or  
C' = 0.8 when the material is thicker than the orifice diameter.

- If different sizes of orifices are used along the riser then they must be sized so that not more than 50 percent of the design storm event drains in one third of the draw down time. This will allow adequate settling time for events smaller than the design storm event. The entire volume of the basin shall be designed to drain within 72 hours or less if required by local vector control regulations. If the basin fails to empty within 72 hours, the basin shall be pumped dry in accordance with the APP (see NS-2 Dewatering Operations BMPs).
- Floating outlet skimmer: The floating outlet skimmer drains water from the upper portion of the water column in the basin. This prevents clogging from bottom sediments. Figure 4 shows the floating outlet skimmer.
- Hold and release valve: A valve system for releasing water from a detention basin is critical. The valve system may be manual, bladder devices or electronic. The valve shall be closed during the rain event and settling time and then released to drain within 72 hours or less if required by local vector regulations.

## Evaluate the Capacity of the Sediment Basin

- Sediment basins cannot be expected to perform as designed if not properly maintained or the sediment yield is larger than expected. Sediment basin design must include maintenance requirements sediment yield and basin storage volume.
- Sediment yield can be estimated using the Modified Universal Soil Loss Equation (MUSLE, Eq. 5) and annual soil loss can be estimated using the Revised Universal Soil Loss Equation (RUSLE, Eq.6).

$$Y = 95 (Q \times q_p)^{0.56} \times K \times LS \times C \times P \text{ (Eq. 5)}$$

$$A = R \times K \times LS \times C \times P \text{ (Eq. 6)}$$

Where:

A = annual soil loss, tons per acre per year

R = rainfall erosion index, in 110 ft. tons/acre in /hour

K = soil erodibility factor, in tons/acre per unit of R

LS = Slope length and steepness factor (unit less)

C = vegetative cover factor (unit less)

P = erosion control practice factor (unit less)

Y – single storm sediment yield in tons

Q = runoff volume in acre-feet

q = peak flow in cfs.

- Determination of the appropriate equation shall consider construction duration and local environmental factors. For example, a year-long project should use RUSLE. Where a project that is less than a year should use the MUSLE. Both equations are used to estimate soil loss and evaluate the sediment storage

volume required and maintenance frequency.

- Soil loss estimates are an essential step in the design and maintenance requirements must be understood by the implementers in the field. Providing maintenance methods, frequencies and specifications shall be included on the SWPPP Site map.
- Once the amount of soil entering the basin is estimated, the depth required for sediment storage shall be determined by dividing the estimated sediment loss by the surface area of the basin.

### **General Requirements**

- The basin shall consist of the following 2 zones:
  - A sediment storage zone of at least 1 foot deep
  - A settling zone at least 2 feet deep
- The basin depth shall be no less than 3 feet deep (not including free board). Free board shall be 1 foot or more as required by local regulations.
- Proper hydraulic design of the outlet is critical to achieving the desired performance of the basin. The water quality outlet should be designed to drain the basin within 24 to 72 hours (also referred to as “drawdown time”). (The 24-hour limit is specified to provide adequate settling time; the 72-hour limit is specified to mitigate vector control concerns.)
- The length to settling depth ratio shall be less than 200.
- SS-10 shall be used to protect the basin inlet and slopes against erosion.
- Design and locate sediment/desilting basins so that they can be maintained. Construct desilting basins prior to construction activities.
- Sediment/desilting basins, regardless of size and storage volume, shall include features to accommodate overflow or bypass flows that exceed the design storm event. The calculated basin volume and proposed location shall be submitted to the Engineer for approval at least 3 days prior to the basin construction.
- Construct an emergency spillway to accommodate flows not carried by the principal spillway.
- Spillway shall consist of an open channel (earthen or vegetated) over undisturbed material (not fill) or constructed of a non-erodible riprap.
- Spillway control section, which is a level portion of the spillway channel at the highest elevation in the channel, shall be a minimum of 20 ft in length.
- A forebay, constructed upstream of the basin may be provided to remove debris and larger particles.

- Basin inlets shall be located to maximize travel distance to the basin outlet.
- If baffles are used, construct them of earthen berms that are stabilized to prevent erosion or other structural materials to divert flows and allow settling throughout the basin. Baffles shall be designed to diver the design flows and allow
- The outflow from the basins shall be provided with outlet protection to prevent erosion and scouring of the embankment and channel. See BMP SS-10, "Outlet Protection/Velocity Dissipation Devices."
- Basin shall be located: (1) by excavating a suitable area or where a low embankment can be constructed across a swale, (2) where post-construction (permanent) detention basins will be constructed, (3) where failure would not cause loss of life or property damage, (4) where the basins can be maintained on a year-round basins to provide access for maintenance, including sediment removal and sediment stockpiling in a protected area, and to maintain the basin to provide the required capacity.
- Areas under embankments, structural works, and sediment/desilting basin must be cleared, stripped of vegetation.
- Structure shall be placed on a firm, smooth foundation with the base securely anchored with concrete or other means to prevent floatation.
- Discharge from the basin shall be accomplished through a water quality outlet. An example is shown in Figure 3. The principal outlet shall consist of a corrugated metal, high density polyethylene (HDPE), or reinforced concrete riser pipe with dewatering holes and an anti-vortex device and trash rack attached to the top of the riser, to prevent floating debris from flowing out of the basin or obstructing the system. This principal structure shall be designed to accommodate the inflow design storm.
- A rock pile or rock-filled gabions can serve as alternatives to the debris screen, although the designer should be aware of the potential for extra maintenance involved should the pore spaces in the rock pile clog.
- The two most common outlet problems that occur are: (1) the capacity of the outlet is too great resulting in only partial filling of the basin and drawdown time less than designed for; and (2) the outlet clogs because it is not adequately protected against trash and debris. To avoid these problems, the following outlet types are recommended for use: (1) a single orifice outlet with or without the protection of a riser pipe, and (2) perforated riser. Design guidance for single orifice and perforated riser outlets are as follows:

***Flow Control Using a Single Orifice At The Bottom Of The Basin (Figure 1):***

The outlet control orifice should be sized using the following equation:

$$a = \frac{2A(H - H_o)^{0.5}}{3600CT(2g)^{0.5}} = \frac{(7 \times 10^{-5})A(H - H_o)^{0.5}}{CT} \quad (\text{Eq. 2})$$

where:

- $a$  = area of orifice (ft<sup>2</sup>)
- $A$  = surface area of the basin at mid elevation (ft<sup>2</sup>)
- $C$  = orifice coefficient
- $T$  = drawdown time of full basin (hrs)
- $G$  = gravity (32.2 ft/s<sup>2</sup>)
- $H$  = elevation when the basin is full (ft)
- $H_o$  = final elevation when basin is empty (ft)

With a drawdown time of 40 hours, the equation becomes:

$$a = \frac{(1.75 \times 10^{-6})A(H - H_o)^{0.5}}{C} \quad (\text{Eq. 3})$$

***Flow Control Using Multiple Orifices (see Figure 2):***

$$a_t = \frac{2A(h_{max})}{CT(2g[h_{max} - h_{centroid\ of\ orifices}])^{0.5}} \quad (\text{Eq. 4})$$

With terms as described above except:

- $a_t$  = total area of orifices
- $h_{max}$  = maximum height from lowest orifice to the maximum water surface (ft)
- $h_{centroid\ of\ orifices}$  = height from the lowest orifice to the centroid of the orifice configuration (ft)

Allocate the orifices evenly on two rows; separate the holes by 3x hole diameter vertically, and by 120 degrees horizontally (refer to Figure 3).

Because basins are not maintained for infiltration, water loss by infiltration should be disregarded when designing the hydraulic capacity of the outlet structure.

- The Contractor shall verify that the outlet is properly designed to handle the design and peak flows.
- Attach riser pipe (watertight connection) to a horizontal pipe (barrel), which extends through the embankment to toe of fill. Provide anti-seep collars on the barrel.
- Cleanout level shall be clearly marked on the riser pipe

Insignificant quantities of accumulated precipitation may be dewatered to the sediment/desilting basin unless precipitation is forecasted within 24 hours. Refer to NS-2 “Dewatering Operations” and the APP.

## Inspection and Maintenance

- Inspect sediment basins weekly and before and after rainfall events. During extended rainfall events, inspect sediment basins at least every 24 hours.
- Examine basin banks for seepage and structural soundness.
- Check inlet and outlet structures and spillway for any damage or obstructions. Repair damage and remove obstructions as needed, or as directed by the Engineer.
- Remove standing water from the basin within 72 hours after accumulation.
- Check inlet and outlet area for erosion and stabilize if required, or if directed by the Engineer.
- Remove accumulated sediment when its volume reaches one-third the volume of the sediment storage. Properly dispose of sediment and debris removed from the basin.
- Check fencing for damage and repair as needed or as directed by the Engineer.

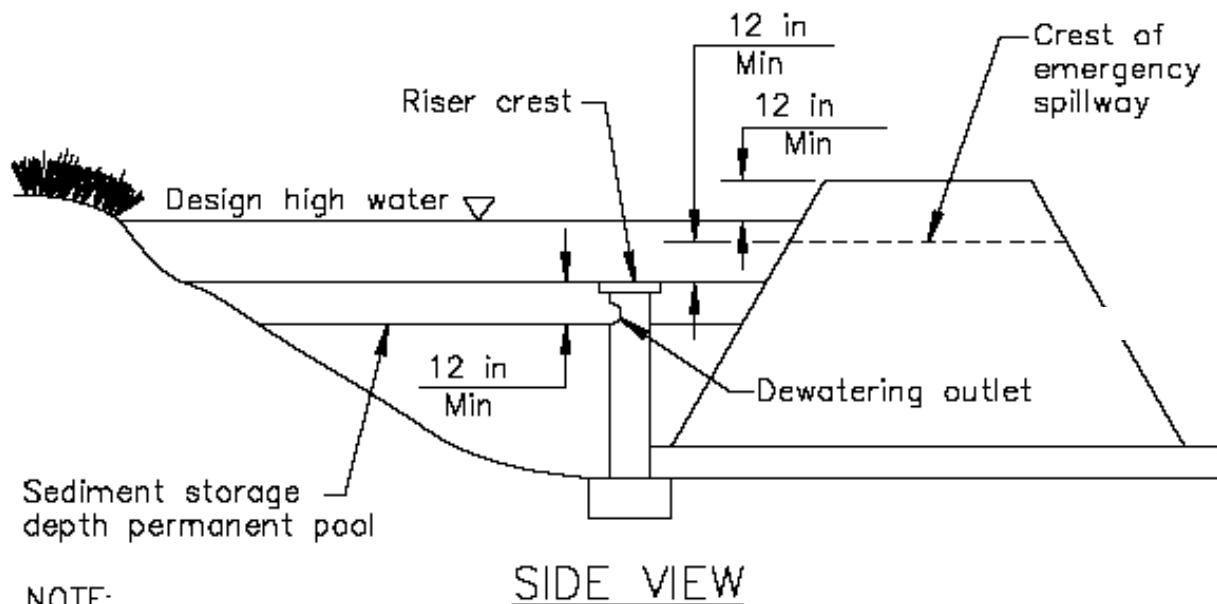
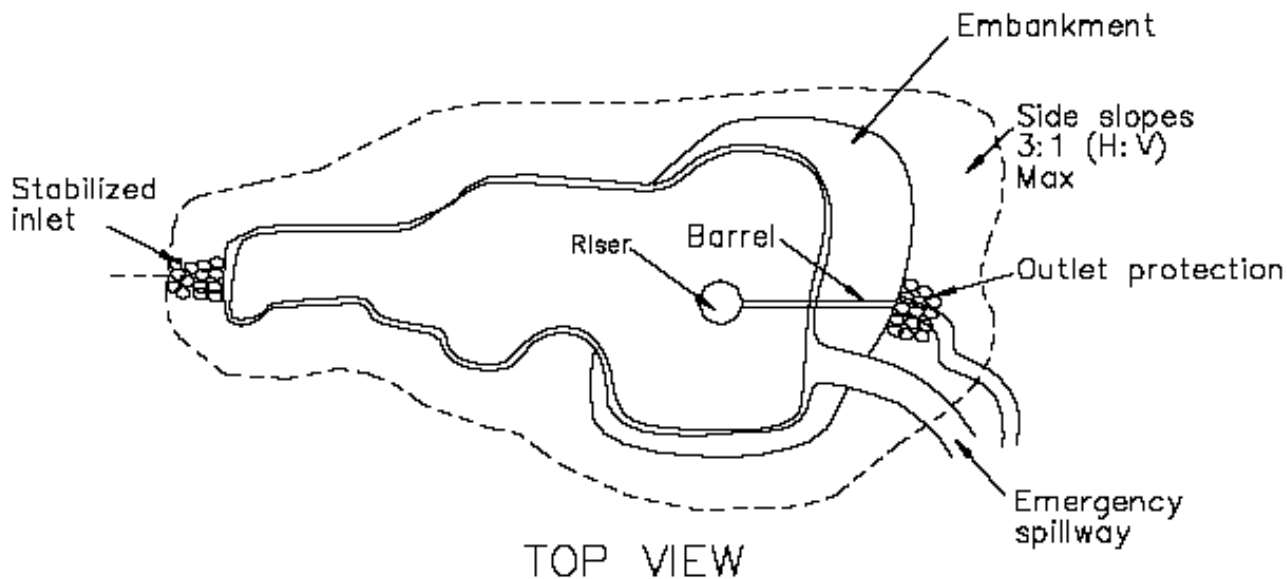

NOTE:  
This outlet provides no drainage  
for permanent pool.

FIGURE 1: TYPICAL TEMPORARY SEDIMENT BASIN  
SINGLE ORIFICE DESIGN  
NOT TO SCALE



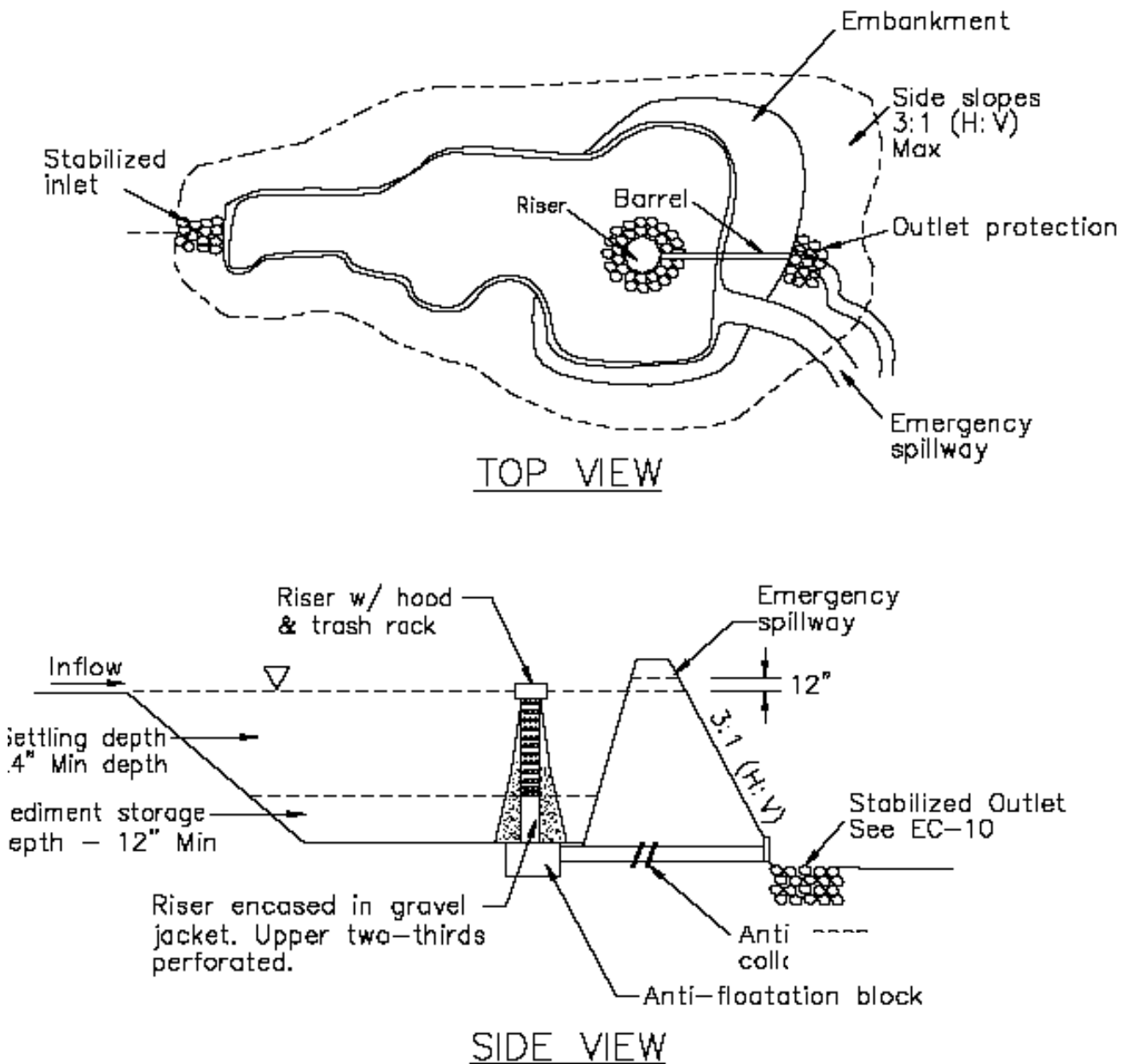

FIGURE 2: TYPICAL TEMPORARY SEDIMENT BASIN  
 MULTIPLE ORIFICE DESIGN  
 NOT TO SCALE

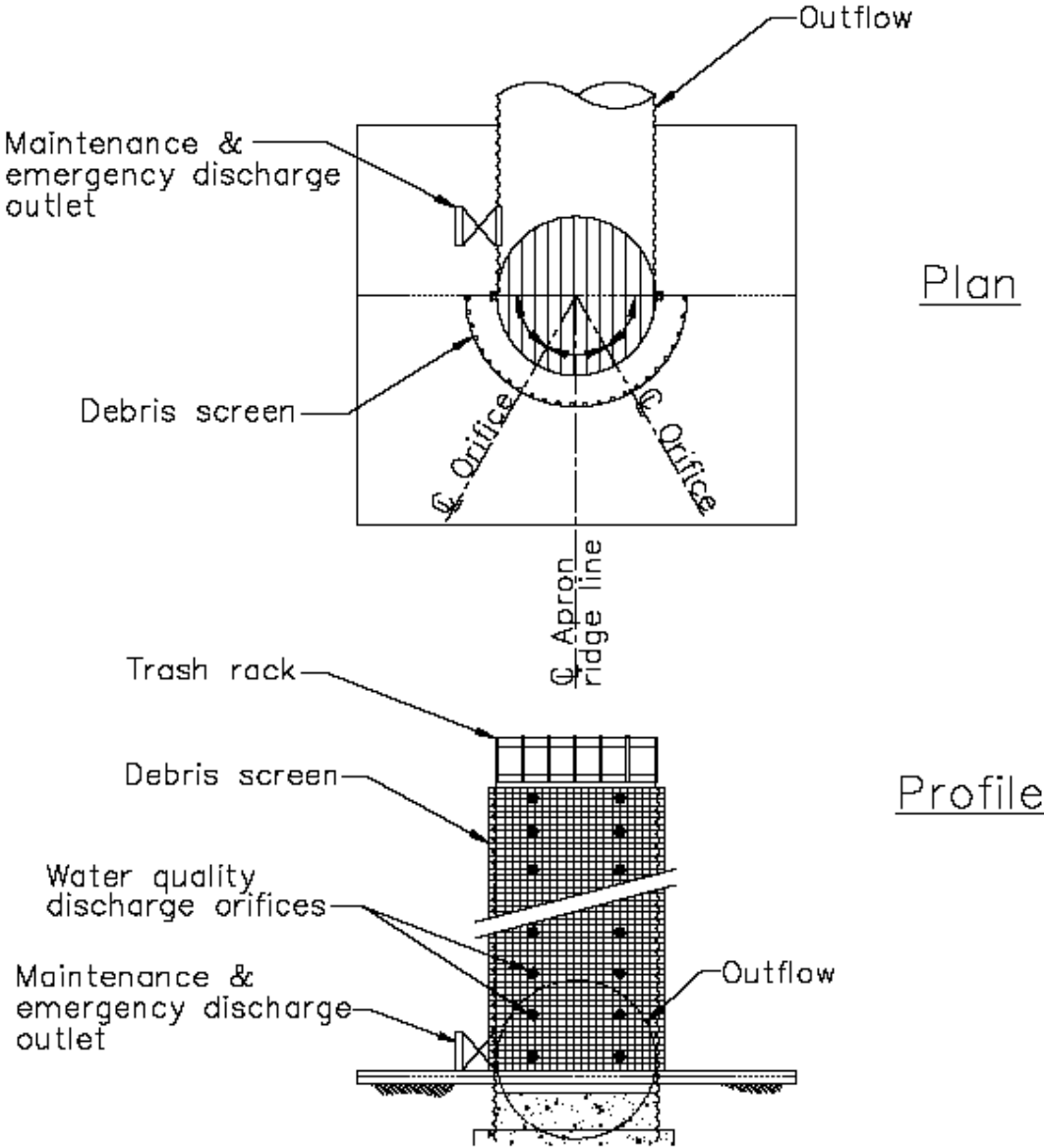

FIGURE 3: MULTIPLE ORIFICE OUTLET RISER  
NOT TO SCALE

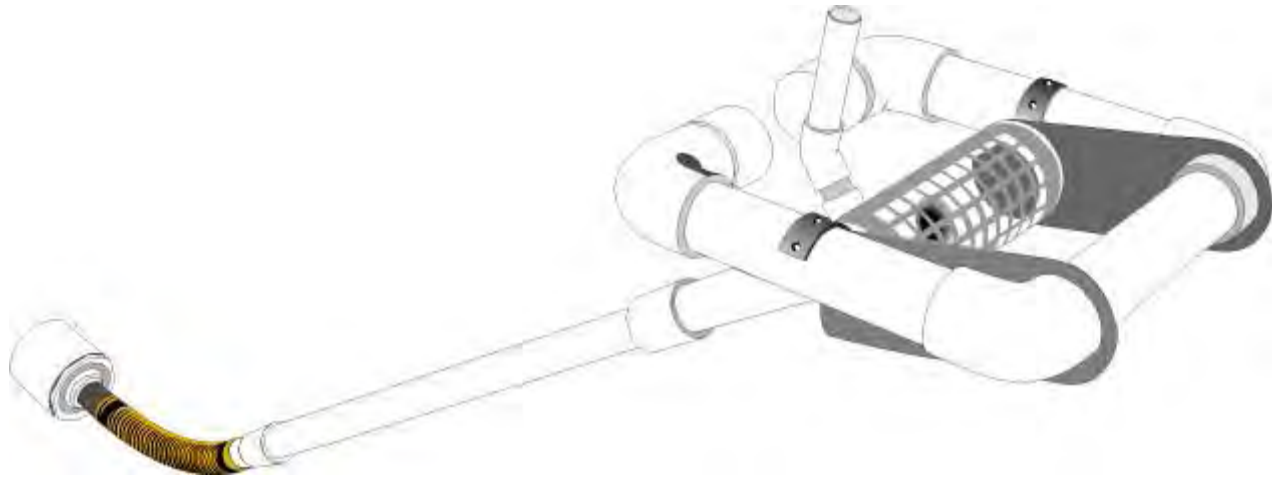
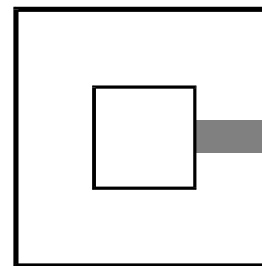
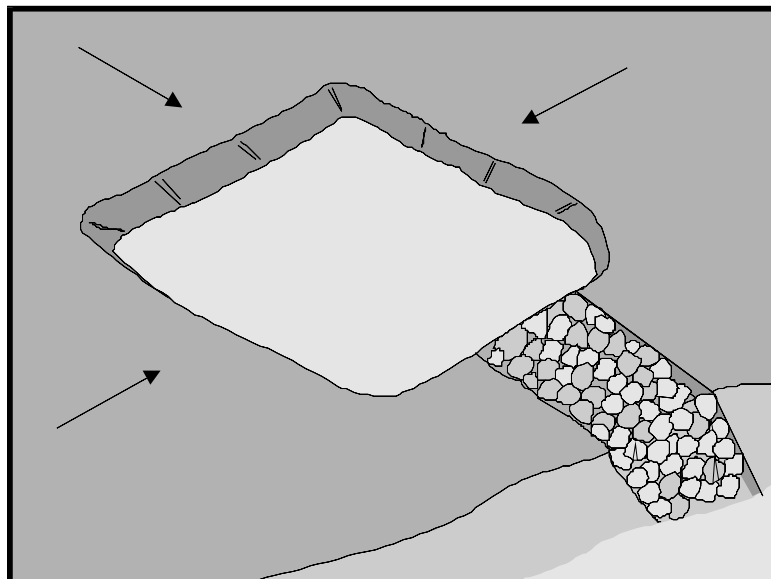

FIGURE 4: FLOATING OUTLET SKIMMER

NOT TO SCALE

(This page left intentionally blank)



Standard Symbol

### BMP Objectives

- Soil Stabilization
- Sediment Control
- Tracking Control
- Wind Erosion Control
- Non-Storm Water Management
- Materials and Waste Management

**Definition and Purpose** A sediment trap is a temporary containment area that allows sediment in collected storm water to settle out during infiltration or before the runoff is discharged through a stabilized spillway. Sediment traps are formed by excavating or constructing an earthen or other embankment across a waterway or low drainage area.

- Appropriate Applications**
- Sediment traps may be used on construction projects where the drainage area is less than 5 ac. Traps should be placed where sediment-laden storm water enters a storm drain or watercourse.
  - This BMP may be implemented on a project-by-project basis with other BMPs when determined necessary and feasible by the Engineer.
  - As a supplemental control, sediment traps provide additional protection for a water body or for reducing sediment before it enters a drainage system.

- Limitations**
- Requires large surface areas to permit infiltration and settling of sediment.
  - Not appropriate for drainage areas greater than 5 ac.
  - Only removes large and medium sized particles and requires upstream erosion control.
  - Size may be limited by availability of area on construction site.

## Standards and Specifications

- Trap shall be situated according to the following criteria: (1) by excavating a suitable area or where a low embankment can be constructed across a swale, (2) where failure would not cause loss of life or property damage, and (3) to provide access for maintenance, including sediment removal and sediment stockpiling in a protected area.
- Trap shall be sized to accommodate a settling zone and sediment storage zone with recommended minimum volumes of 67 yd<sup>3</sup>/ac and 33 yd<sup>3</sup>/ac of contributing drainage area, respectively, based on 0.5 inches of runoff volume over a 24-hr period. Multiple traps and/or additional volume may be required to accommodate site specific rainfall and soil conditions.
- Sediment/desilting basin shall be designed by a professional Engineer registered with the State of California. The design details shall be included in the SWPPP or SWPPP amendment or approved by the Engineer prior to construction.
- The design shall include maintenance requirements, including sediment and vegetation removal, to ensure continuous function of the trap outlet and bypass structures.
- Areas under embankments, structural works, and sediment traps shall be cleared and stripped of vegetation and root material. The pool area shall be cleared.
- Use SS-10 to protect the trap outlets against erosion.
- Fencing shall be provided to prevent unauthorized entry.

## Maintenance and Inspection

- Inspect sediment traps a minimum of weekly, before and after rainfall events. During extended rainfall events, inspect sediment traps at least every 24 hours.
- If captured runoff has not completely infiltrated within 72 hours, the sediment trap must be dewatered per NS-2 requirements.
- Inspect trap banks for embankment seepage and structural soundness. Inspect outlet area for erosion and stabilize as required, or as directed by the Engineer.
- Inspect outlet structure and rock spillway for any damage or obstructions. Repair damage and remove obstructions as needed or as directed by the Engineer.
- Remove accumulated sediment when the volume has reached one-third the original trap volume. Properly dispose of sediment and debris removed from the trap.
- Inspect fencing for damage and repair as needed or as directed by the Engineer.

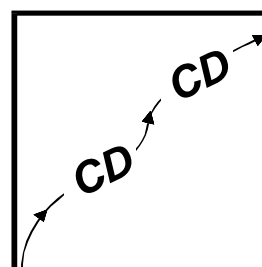
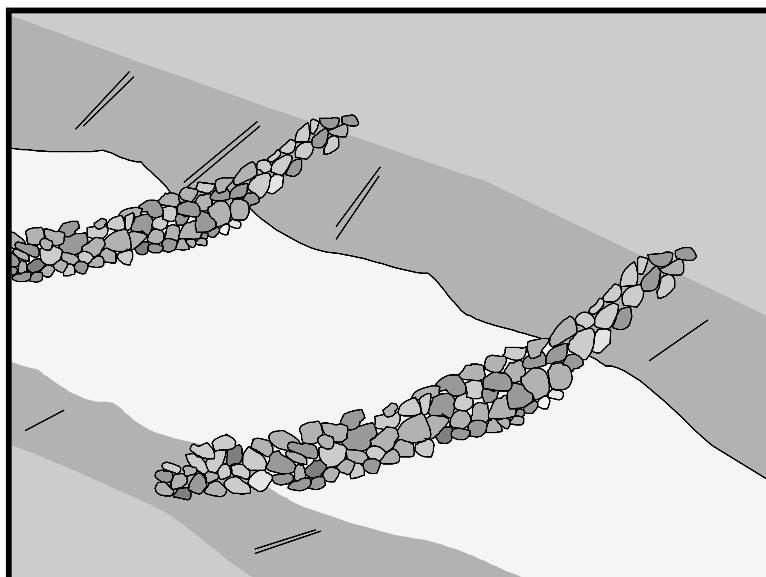

- BMP Objectives**

  - Soil Stabilization
  - Sediment Control
  - Tracking Control
  - Wind Erosion Control
  - Non-Storm Water Management
  - Materials and Waste Management

**Definition and Purpose** Check dams reduce scour and channel erosion by reducing flow velocity and encouraging sediment settlement. A check dam is a small device constructed of rock, gravel bags, sandbags, fiber rolls, or other appropriate product placed across a natural or man-made channel or drainage ditch.

- Appropriate Applications**
- Check dams may be installed:
    - In small open channels that drain 10 ac or less.
    - In steep channels where storm water runoff velocities exceed 4.9 ft/sec.
    - During the establishment of grass linings in drainage ditches or channels.
    - In temporary ditches where the short length of service does not warrant establishment of erosion-resistant linings.
  - This BMP may be implemented on a project-by-project basis with other BMPs when determined necessary and feasible by the Engineer.

- Limitations**
- Not to be used in live streams.
  - Not appropriate in channels that drain areas greater than 10 ac.
  - Not to be placed in channels that are already grass lined unless erosion is expected, as installation may damage vegetation.
  - Require extensive maintenance following high velocity flows.
  - Promotes sediment trapping, which can be re-suspended during subsequent storms or removal of the check dam.
  - Not to be placed in lined ditches designed for concentrated flow. Sediment must be prevented prior to entering lined or paved drain facilities.
  - Not to be constructed from straw bales or silt fence.

## Standards and Specifications

- Check dams shall be placed at a distance and height to allow small pools to form behind them. Install the first check dam approximately 16 ft from the outfall device and at regular intervals based on slope gradient and soil type.
- For multiple check dam installation, backwater from downstream check dam shall reach the toe of the upstream dam.
- High flows (typically a 2-year storm or larger) shall safely flow over the check dam without an increase in upstream flooding or damage to the check dam.
- Where grass is used to line ditches, check dams shall be removed when grass has matured sufficiently to protect the ditch or swale.
- Rock shall be placed individually by hand or by mechanical methods (no dumping of rock) to achieve complete ditch or swale coverage.
- Fiber rolls may be used as check dams if approved by the Engineer. Refer to SC-5 “Fiber Rolls.”
- Gravel bags may be used as check dams with the following specifications:

### **Materials**

- **Bag Material:** Bags shall be either polypropylene, polyethylene or polyamide woven fabric, minimum unit weight (four ounces per square yard), mullen burst strength exceeding 300 psi in conformance with the requirements in ASTM designation D3786, and ultraviolet stability exceeding 70% in conformance with the requirements in ASTM designation D4355.
- **Bag Size:** Each gravel-filled bag shall have a length of 18 in., width of 12 in., thickness of 3 in., and mass of approximately 33 lb. Bag dimensions are nominal, and may vary based on locally available materials. Alternative bag sizes shall be submitted to the Engineer for approval prior to deployment.
- **Fill Material:** Fill material shall be between 0.4 and 0.8 inch in diameter, and shall be clean and free from clay balls, organic matter, and other deleterious materials. The opening of gravel-filled bags shall be secured such that gravel does not escape. Gravel-filled bags shall be between 28 and 48 lb in mass. Fill material is subject to approval by the Engineer.

### **Installation**

- Install along a level contour.
- Tightly abut bags and stack gravel bags using a pyramid approach. Gravel bags shall not be stacked any higher than 3.2 ft.
- Upper rows of gravel bags shall overlap joints in lower rows.



## Maintenance and Inspection

- Inspect all check dams weekly and before and after every rainfall events. During extended rainfall events, inspect check dams at least once every 24 hours.
- Remove sediment when depth reaches one-third of the check dam height.
- Remove accumulated sediment prior to permanent seeding or soil stabilization.
- Remove check dam and accumulated sediment when check dams are no longer needed or when required by the Engineer.
- Removed sediment shall be incorporated in the project at locations designated by the Engineer or disposed of in conformance with all applicable laws and regulations. If removed sediment is stored on site, it shall be in accordance with WM-3 Stockpile Management.



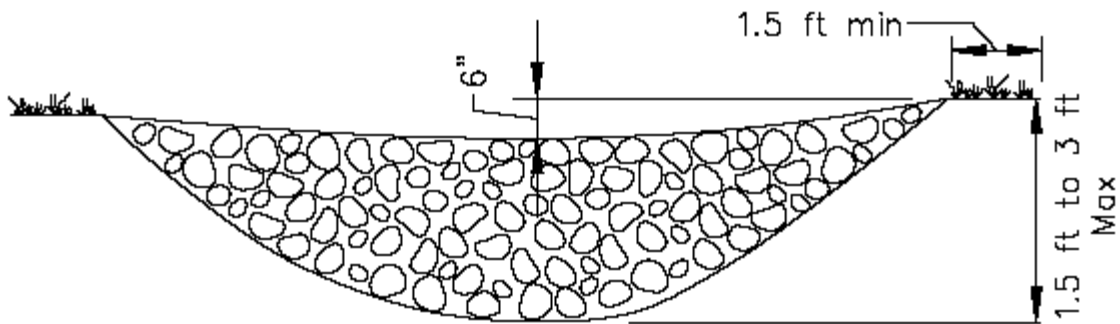

ELEVATION

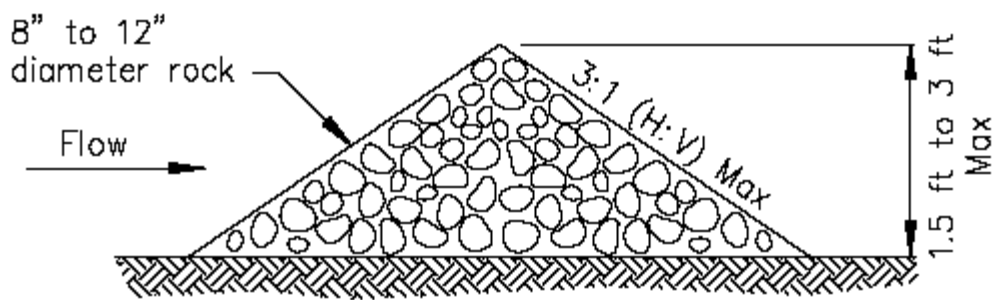

TYPICAL ROCK CHECK DAM SECTION

ROCK CHECK DAM  
NOT TO SCALE

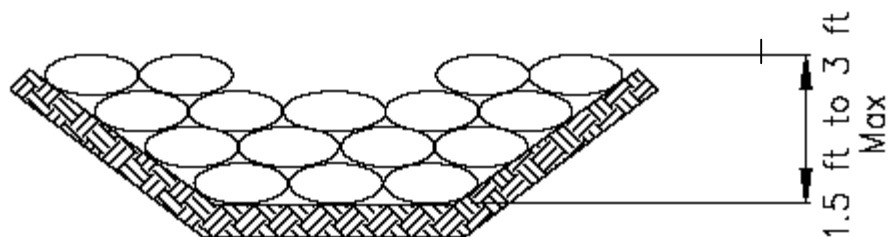

GRAVEL BAG CHECK DAM ELEVATION  
NOT TO SCALE

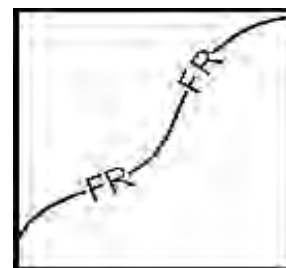

Standard Symbol

### BMP Objectives

- Soil Stabilization
- Sediment Control
- Tracking Control
- Wind Erosion Control
- Non-Storm Water Management
- Materials and Waste Management

**Definition and Purpose** A fiber roll consists of wood excelsior, rice or wheat straw, or coconut fibers that is rolled or bound into a tight tubular roll and placed on the toe and face of slopes to intercept runoff, reduce its flow velocity, release the runoff as sheet flow and provide removal of sediment from the runoff. Fiber rolls may also be used for run-on diversion, inlet protection and check dams under certain situations.

- Appropriate Applications**
- This BMP may be implemented on a project-by-project basis with other BMPs when determined necessary and feasible by the Contractor or Engineer.
  - Along the toe, top, face, and at grade breaks of exposed and erodible slopes to shorten slope length and spread runoff as sheet flow.
  - Below the toe of exposed and erodible slopes.
  - Fiber rolls may be used as check dams in unlined ditches if approved by the Engineer (refer to SC-4 “Check Dams”).
  - Fiber rolls may be used for drain inlet protection if they can be properly anchored and if approved by the Engineer (refer to SC-10 “Storm Drain Inlet Protection”).
  - Fiber rolls may be used for run-on diversion when properly anchored and approved by the Engineer.
  - Down-slope of exposed soil areas.
  - Around temporary stockpiles.
  - Along the perimeter of a project.

- Limitations**
- Runoff and erosion may occur if the fiber roll is not adequately trenched in.
  - Fiber rolls at the toe of slopes greater than 1:5 may require the use of 20" diameter rolls or installations achieving the same protection (i.e., stacked smaller diameter fiber rolls, etc.).
  - Difficult to move once saturated.
  - Fiber rolls could be transported by high flows if not properly staked and trenched in.
  - Fiber rolls have limited sediment capture zone.
  - Do not use fiber rolls on slopes subject to creep, slumping, or landslide.

**Standards and Specifications**

***Fiber Roll Materials***

- Fiber rolls shall be either:
  - Prefabricated rolls.
  - Rolled tubes of erosion control blanket.

***Assembly of Field Rolled Fiber Roll***

- Roll length of erosion control blanket into a tube of minimum 8 in. diameter.
- Bind roll at each end and every 4 ft. along length of roll with jute-type twine.

***Installation***

- Slope inclination of 1:4 or flatter: fiber rolls shall be placed on slopes 20 ft. (6m) apart.
- Slope inclination of 1:4 to 1:2: fiber rolls shall be placed on slopes 15 ft. (4.5 m) apart.
- Slope inclination 1:2 or greater: fiber rolls shall be placed on slopes 10 ft. (3 m) apart.
- Stake fiber rolls into a 2 to 4 in. trench.
- Use wood stakes with a nominal classification of 3/4 by 3/4 in, and minimum length of 24 in. Drive stakes at the end of each fiber roll and spaced 2 ft (600 mm) apart if Type 2 installation is used (refer to Page 4). Otherwise, space stakes 4 ft maximum on center if installed as shown on Pages 5 and 6.
- If more than one fiber roll is placed in a row, the rolls shall be overlapped; not abutted.

## ***Removal***

- Fiber rolls are typically left in place.
- If fiber rolls are removed, collect and dispose of sediment accumulation, and fill and compact holes, trenches, depressions or any other ground disturbance to blend with adjacent ground.

## **Maintenance and Inspection**

- Ensure that all perimeter controls are maintained and protected from activities that reduce their effectiveness.
- Repair or replace split, torn, unraveling, or slumping fiber rolls.
- Inspect all fiber rolls weekly and before and after every rainfall events. During extended rainfall events, inspect fiber rolls at least once every 24 hours.
- Perform maintenance as needed or as required by the Engineer.
- Maintain fiber rolls to provide an adequate sediment holding capacity. Sediment shall be removed when the sediment accumulation reaches three quarters (3/4) of the barrier height. Removed sediment shall be incorporated in the project at locations designated by the Engineer or disposed of outside the highway right-of-way in conformance with all applicable laws and regulations. If removed sediment is stored on site, it shall be in conformance with WM-3 Stockpile Management.

# Fiber Rolls

SC-5

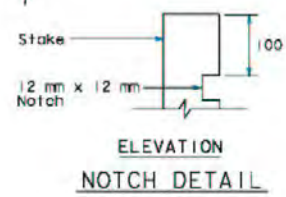
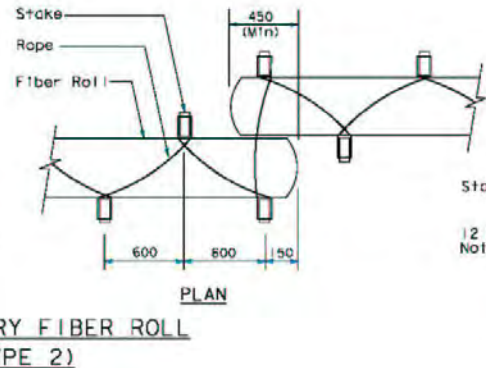
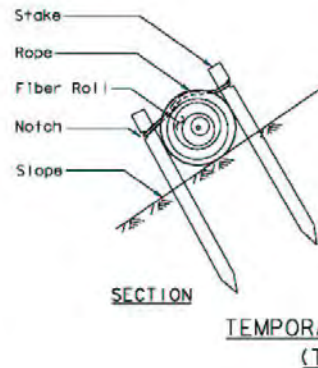
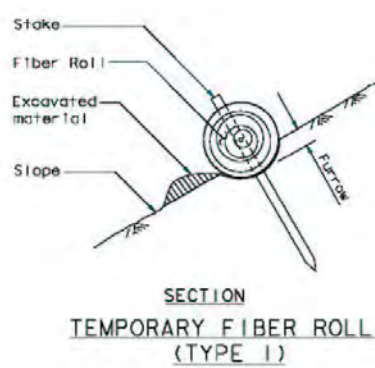

NOTE  
1. Temporary fiber roll spacing varies depending upon slope inclination.

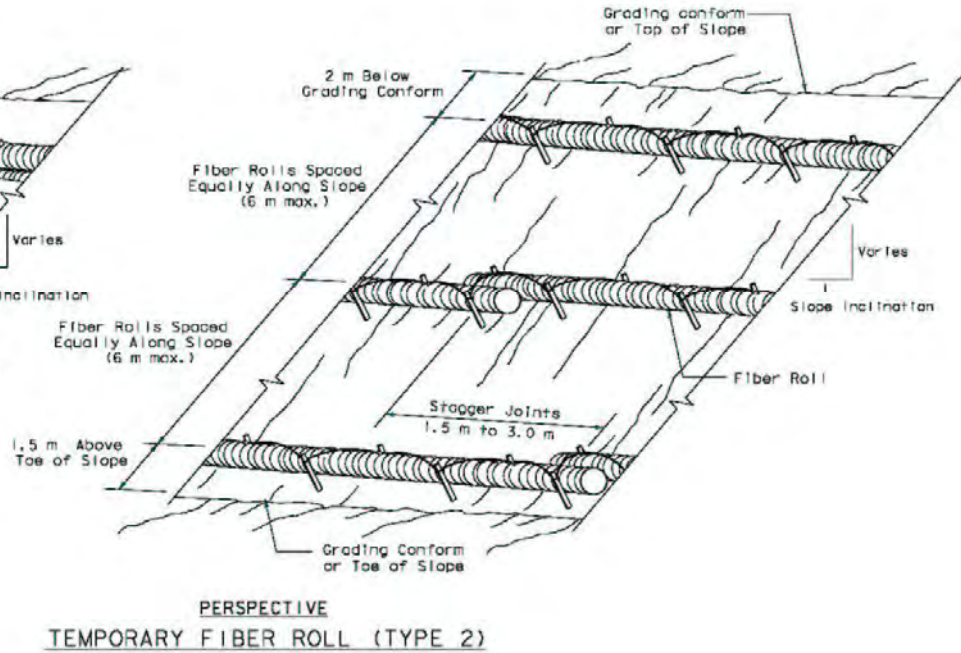
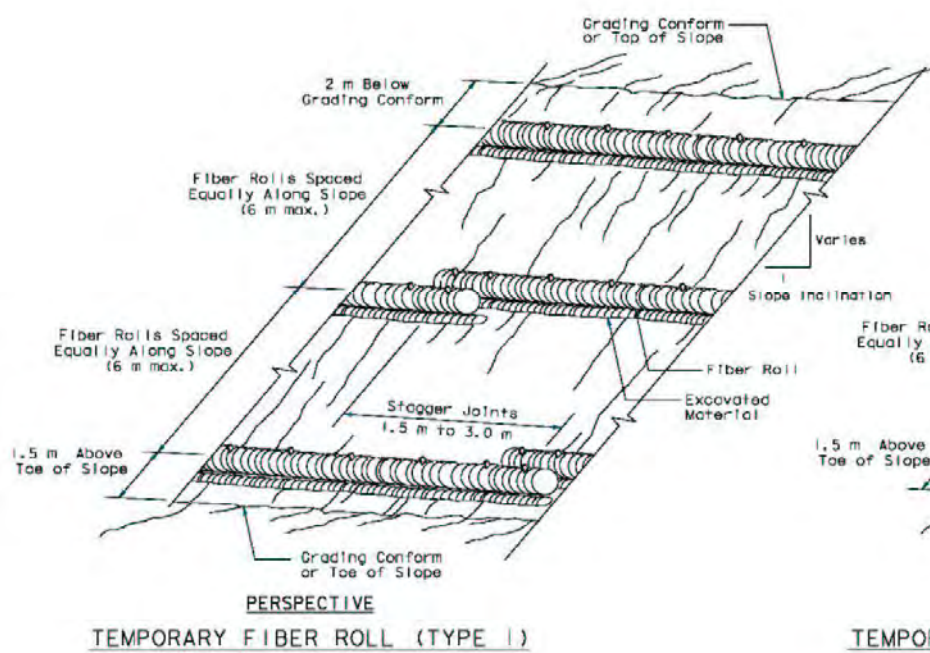

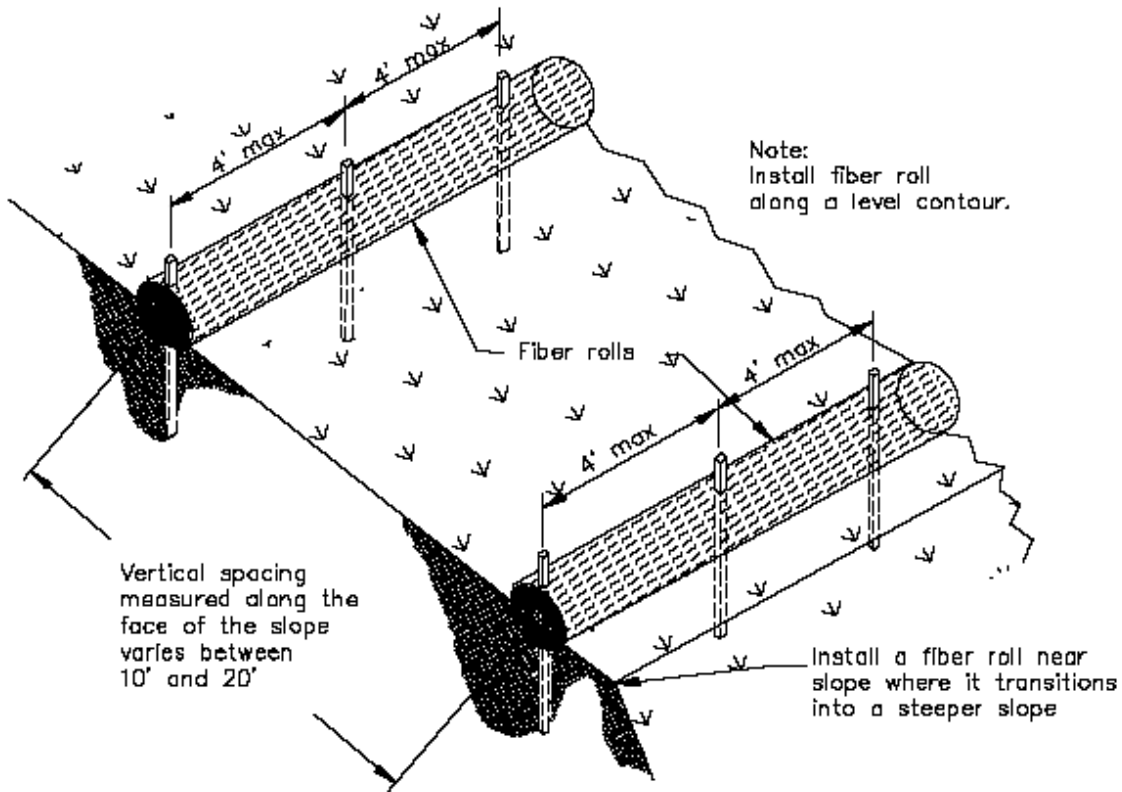

TYPICAL FIBER ROLL INSTALLATION

N.T.S.

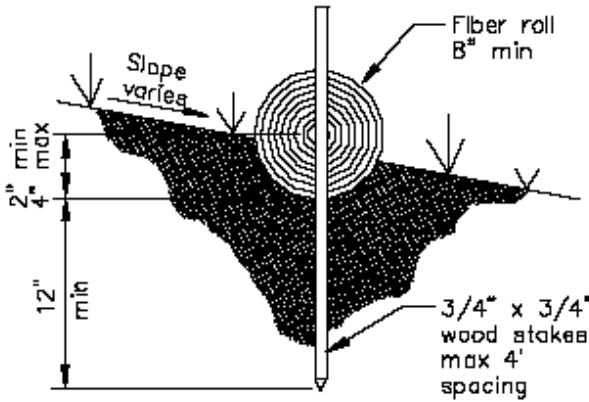

ENTRENCHMENT DETAIL

N.T.S.



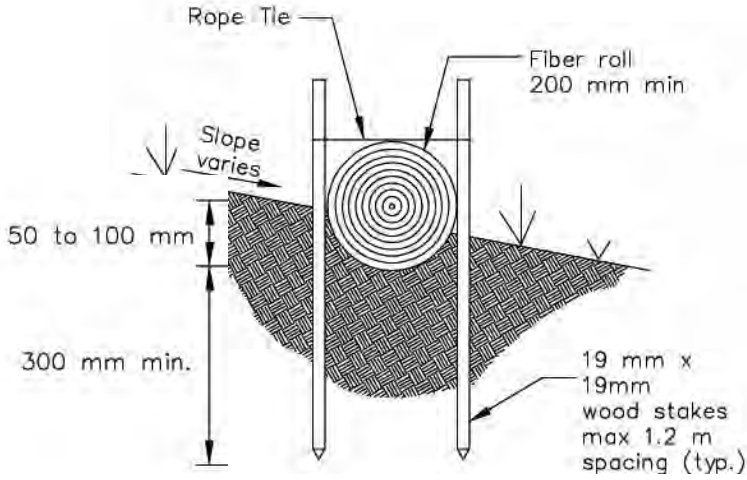
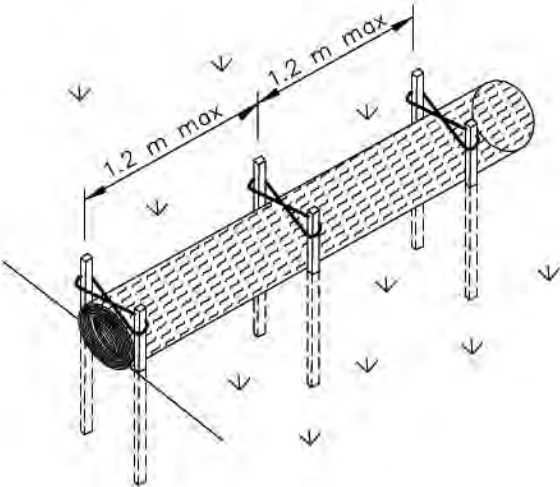

OPTIONAL ENTRENCHMENT DETAIL  
N.T.S.



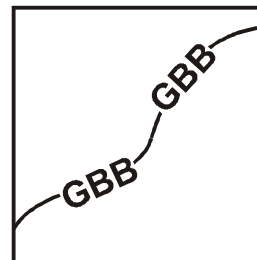
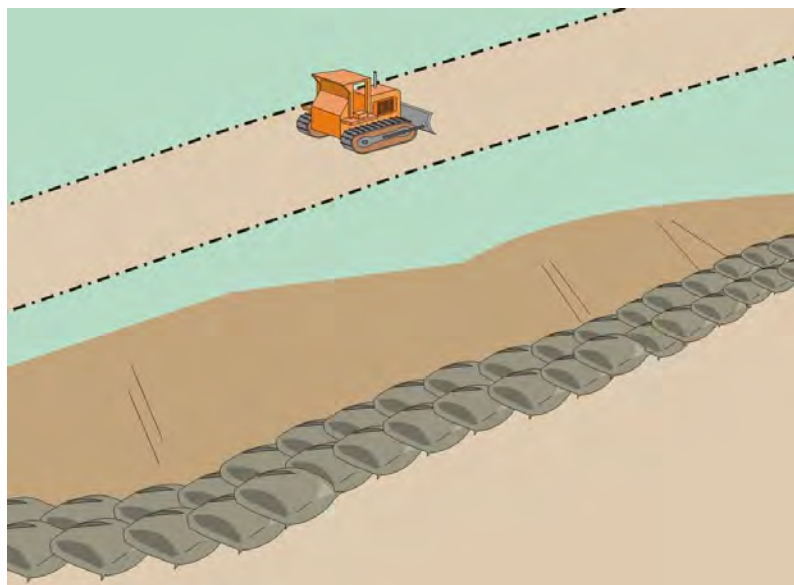

Standard Symbol

### BMP Objectives

- Soil Stabilization
- Sediment Control
- Tracking Control
- Wind Erosion Control
- Non-Storm Water Management
- Materials and Waste Management

**Definition and Purpose** A gravel bag berm consists of one or more rows of gravel bags that are installed end to end to form a barrier across a slope to intercept runoff, reduce its flow velocity, release the runoff as sheet flow and provide some sediment removal. Gravel bags can be used where flows are moderately concentrated, such as ditches, swales, and storm drain inlets (see BMP SC-10, Storm Drain Inlet Protection), and to divert and/or detain flows.

- Appropriate Applications**
- BMP may be implemented on a project-by-project basis with other BMPs when determined necessary and feasible by the Contractor or Engineer.
  - Along streams and channels.
  - Below the toe of exposed and erodible slopes.
  - At grade breaks of exposed and erodible slopes to shorten slope length and spread runoff as sheet flow.
    - Slope inclination of 1:4 or flatter: fiber rolls shall be placed on slopes 20 ft. (6m) apart.
    - Slope inclination of 1:4 to 1:2: fiber rolls shall be placed on slopes 15 ft. (4.5 m) apart.
    - Slope inclination 1:2 or greater: fiber rolls shall be placed on slopes 10 ft. (3 m) apart.
  - Around stockpiles.
  - Across channels to serve as a barrier for utility trenches or provide a temporary channel crossing for construction equipment, to reduce stream impacts.
  - Parallel to a roadway to keep sediment off paved areas.

- At the top of slopes to divert runoff away from disturbed slopes.
- Along the perimeter of a site.
- To divert or direct flow or create a temporary sediment basin.
- During construction activities in stream beds when the contributing drainage area is less than 5 ac.
- When site conditions or construction sequencing require adjustments or relocation of the barrier to meet changing field conditions and needs during construction.
- Gravel bag berms may be used as check dams in accordance with SC-4.

## Limitations

- Degraded gravel bags may rupture, spilling contents.
- Installation can be labor intensive.
- Limited durability for long term projects.
- When used to detain concentrated flows, maintenance requirements increase.

## Standards and Specifications

### **Materials**

- **Bag Material:** Bags shall be woven polypropylene, polyethylene or polyamide fabric, minimum unit weight four ounces per square yard, mullen burst strength exceeding 300 psi in conformance with the requirements in ASTM designation D3786, and ultraviolet stability exceeding 70% in conformance with the requirements in ASTM designation D4355.
- **Bag Size:** Each gravel-filled bag shall have a length of 18 in., width of 12 in., thickness of 3 in., and mass of approximately 33 lb. Bag dimensions are nominal, and may vary based on locally available materials. Alternative bag sizes shall be submitted to the Engineer for approval prior to deployment.
- **Fill Material:** Gravel shall be between 0.4 and 0.8 inch in diameter, and shall be clean and free from clay balls, organic matter, and other deleterious materials. The opening of gravel-filled bags shall be secured such that gravel does not escape. Gravel-filled bags shall be between 28 and 48 lb in mass. Fill material is subject to approval by the Engineer.

### **Installation**

- When used as a linear control for sediment removal:
  - Install along a level contour.
  - Turn ends of gravel bag row up slope to prevent flow around the ends.
  - Generally, gravel bag barriers shall be used in conjunction with temporary soil stabilization controls up slope to provide effective erosion and sediment control.

- When used for concentrated flows:
  - Stack gravel bags to required height using a pyramid approach.
  - Upper rows of gravel bags shall overlap joints in lower rows.
- Construct gravel bag barriers with a set-back of at least 3 ft from the toe of a slope to maximize sediment storage capacity. Where it is determined to be not practicable due to specific site conditions, the gravel bag barrier may be constructed at the toe of the slope, but shall be constructed as far from the toe of the slope as practicable.
- Contractor shall certify compliance with these specifications when installing gravel bag berms.

## Maintenance and Inspection

- Ensure that all perimeter controls are maintained and protected from activities that reduce their effectiveness.
- Inspect all gravel bag berms weekly and before and after every rainfall events. During extended rainfall events, inspect gravel bag berms at least once every 24 hours.
- Reshape or replace gravel bags as needed, or as directed by the Engineer.
- Repair washouts or other damages as needed, or as directed by the Engineer.
- Inspect gravel bag berms for sediment accumulation and remove sediment when accumulation reaches one-third of the berm height. Removed sediment shall be incorporated in the project at locations designated by the Engineer or disposed of outside the highway right-of-way in conformance with all applicable laws and regulations. If removed sediment is stored on site, it shall be stored in performance with WM-3 Stockpile Management.
- Remove gravel bag berms when no longer needed. Remove accumulated sediment and clean, re-grade, and stabilize the area.

(This page left intentionally blank)

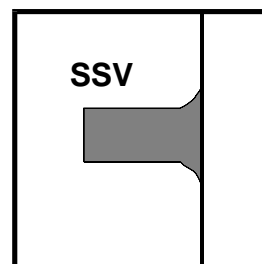

Standard Symbol

- BMP Objectives**

  - Soil Stabilization
  - Sediment Control
  - Tracking Control
  - Wind Erosion Control
  - Non-Storm Water Management
  - Materials and Waste Management

**Definition and Purpose** Practices to remove tracked sediment to prevent the sediment from entering a storm drain or watercourse.

**Appropriate Applications** These practices are implemented anywhere sediment is tracked from the project site onto public or private paved roads, typically at points of ingress/egress.

**Limitations** Sweeping and vacuuming may not be effective when soil is wet or muddy.

- Standards and Specifications**
- Streets will be cleaned in such a manner as to prevent unauthorized non-storm water discharges from reaching surface water or MS4 drainage systems.
  - Manually sweep or shovel may be used or a sweeper/vacuum truck. The swept sediment and debris shall be vacuumed or contained and swept off site.
  - Kick brooms or sweeper attachments shall not be used.
  - Visible sediment tracking shall be swept and/or vacuumed daily.
  - If not mixed with debris or trash, consider incorporating the removed sediment back into the project.

- Maintenance and Inspection**
- Inspect ingress/egress access points daily and sweep tracked sediment as needed, or as required by the Engineer.
  - Be careful not to sweep up any unknown substance or any object that may be potentially hazardous.
  - Adjust brooms frequently; maximize efficiency of sweeping operations.
  - After sweeping is finished, properly dispose of sweeper wastes at an approved dumpsite per WM-5 and WM-6 for proper disposal procedures.

(This page left intentionally blank)

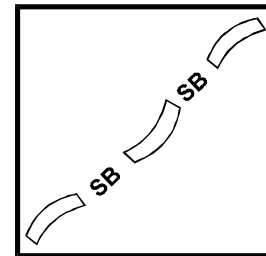
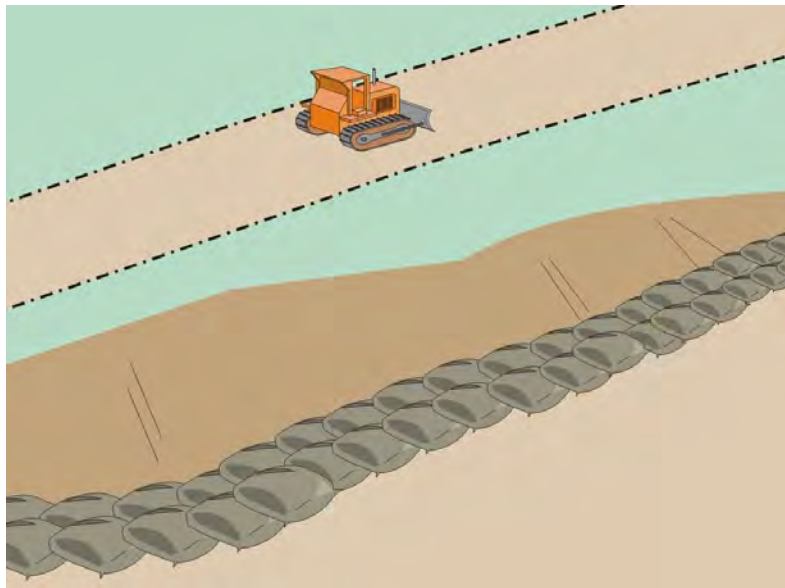

Standard Symbol

### BMP Objectives

- Soil Stabilization
- Sediment Control
- Tracking Control
- Wind Erosion Control
- Non-Storm Water Management
- Materials and Waste Management

**Definition and Purpose** A sandbag barrier is a temporary linear sediment barrier consisting of stacked sandbags, designed to intercept and slow the flow of sediment-laden sheet flow runoff. Sandbag barriers allow sediment to settle from runoff before water leaves the construction site.

- Appropriate Applications**
- This BMP may be implemented on a project-by-project basis in addition to other BMPs when determined necessary and feasible by the Contractor or Engineer.
  - Along the perimeter of a site.
  - Along streams and channels.
  - Below the toe of exposed and erodible slopes.
  - Down slope of exposed soil areas.
  - Around stockpiles.
  - Across channels to serve as a barrier for utility trenches or provide a temporary channel crossing for construction equipment, to reduce stream impacts.
  - Parallel to a roadway to keep sediment off paved areas.
  - At the top of slopes to divert roadway runoff away from disturbed slopes.
  - To divert or direct flow or create a temporary sediment/desilting basin.
  - During construction activities in stream beds when the contributing drainage area is less than 5 ac.

- With plastic cover along the perimeter of vehicle and equipment fueling and maintenance areas or chemical storage areas.
- To capture and detain non-storm water flows until proper cleaning operations occur.
- When site conditions or construction sequencing require adjustments or relocation of the barrier to meet changing field conditions and needs during construction.
- To temporarily close or continue broken, damaged or incomplete curbs.

## Limitations

- Limit the drainage area upstream of the barrier to 5 ac.
- Degraded sandbags may rupture spilling sand.
- Installation can be labor intensive.
- Limited durability for long-term projects.
- When used to detain concentrated flows, maintenance requirements increase.

## Standards and Specifications

### **Materials**

- Sandbag Material: Sandbag shall be woven polypropylene, polyethylene or polyamide fabric, minimum unit weight four ounces per square yard, mullen burst strength exceeding 300 psi in conformance with the requirements in ASTM designation D3786, and ultraviolet stability exceeding 70% in conformance with the requirements in ASTM designation D4355. Use of burlap is not acceptable.
- Sandbag Size: Each sand-filled bag shall have a length of 18 in., width of 12 in., thickness of 3 in., and mass of approximately 33 lb. Bag dimensions are nominal, and may vary based on locally available materials. Alternative bag sizes shall be submitted to the Engineer for approval prior to deployment.
- Fill Material: All sandbag fill material shall be non-cohesive, Class 1 or Class 2 permeable material free from clay and deleterious material. Fill material is subject to approval by the Engineer.

### **Installation**

- When used as a linear sediment control:
  - Install along a level contour.
  - Turn ends of sandbag row up slope to prevent flow around the ends.
  - Generally, sandbag barriers shall be used in conjunction with temporary soil stabilization controls up slope to provide effective erosion and sediment control.
  - Install as shown in Pages 4 and 5 of this BMP.



## Maintenance and Inspection

- Construct sandbag barriers with a set-back of at least 3 ft from the toe of a slope. Where a setback is determined to be not practical due to specific site conditions, the sandbag barrier may be constructed at the toe of the slope, but shall be constructed as far from the toe of the slope as practicable.
- Ensure that all perimeter controls are maintained and protected from activities that reduce their effectiveness.
- Inspect all sandbag barriers weekly and before and after every rainfall events. During extended rainfall events, inspect sandbag barriers at least once every 24 hours.
- Reshape or replace sandbags as needed, or as directed by the Engineer.
- Repair washouts or other damages as needed, or as directed by the Engineer.
- Inspect sandbag barriers for sediment accumulations and remove sediments when accumulation reaches one-third the barrier height. Removed sediment shall be incorporated in the project at locations designated by the Engineer or disposed of off the construction site in conformance with all applicable laws and regulations. If accumulated sediment is stored on site, it shall be in accordance with WM-3 Stockpile Management.
- Remove sandbags when no longer needed. Remove sediment accumulation, and clean, re-grade, and stabilized the area.

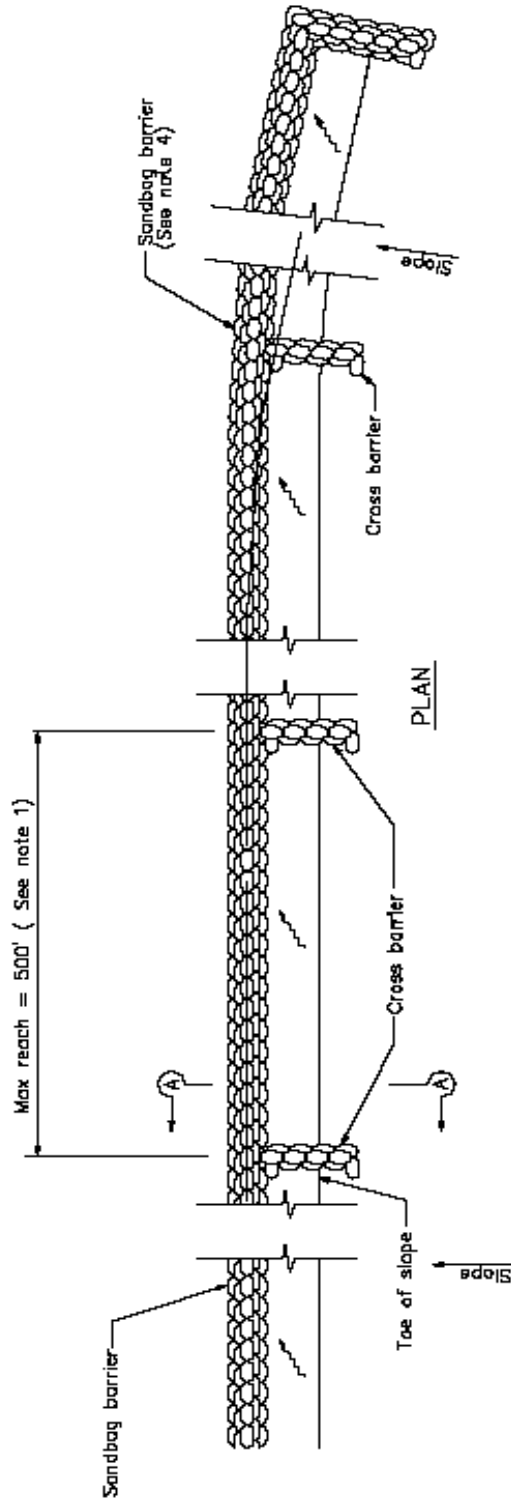

SANDBAG BARRIER

NOTES

1. Construct the length of each reach so that the change in base elevation along the reach does not exceed  $1/2$  the height of the linear barrier. In no case shall the reach length exceed 500'.
2. Place sandbags tightly.
3. Dimensions may vary to fit field condition.
4. Sandbag barrier shall be a minimum of 3 bags high.
5. The end of the barrier shall be turned up slope.
6. Cross barriers shall be a min of  $1/2$  and a max of  $2/3$  the height of the linear barrier.
7. Sandbag rows and layers shall be staggered to eliminate gaps.

# Sandbag Barrier

SC-8

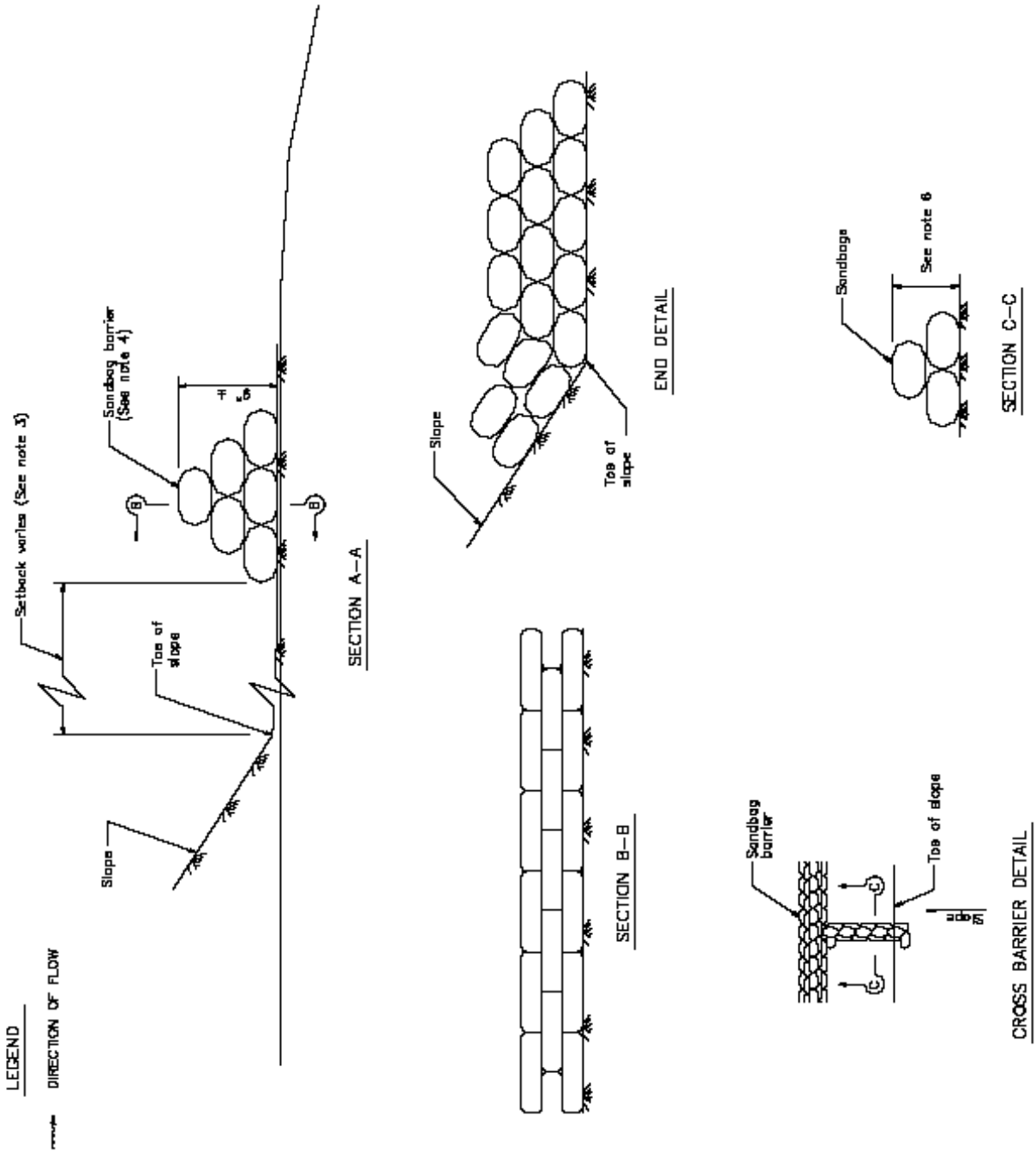

(This page left intentionally blank)

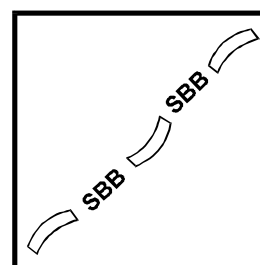
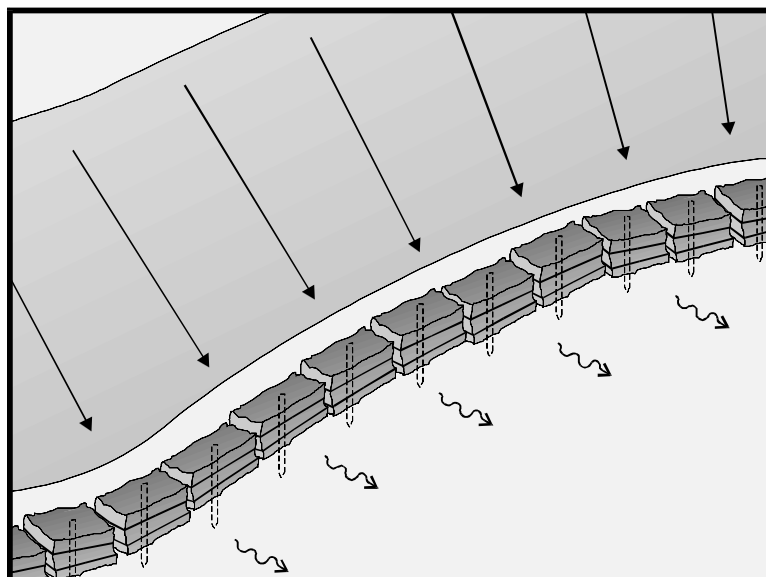

Standard Symbol

### BMP Objectives

- Soil Stabilization
- Sediment Control
- Tracking Control
- Wind Erosion Control
- Non-Storm Water Management
- Materials and Waste Management

**Definition and Purpose** A straw bale barrier is a temporary linear sediment barrier consisting of straw bales, designed to intercept and slow sediment-laden sheet flow runoff. Straw bale barriers allow sediment to settle from runoff before water leaves the construction site.

- Appropriate Applications**
- This BMP may be implemented on a project-by-project basis in addition to other BMPs when determined necessary and feasible by the Contractor or Engineer.
  - Along the perimeter of a site.
  - Along streams and channels.
  - Below the toe of exposed and erodible slopes.
  - Down slope of exposed soil areas.
  - Around stockpiles.
  - Across minor swales or ditches with small catchments.
  - Around above grade type temporary concrete washouts (See BMP WM-8, “Concrete Waste Management”).
  - Parallel to a roadway to keep sediment off paved areas.

- Limitations**
- Installation can be labor intensive.
  - Straw bale barriers are maintenance intensive.
  - Degraded straw bales may fall apart when removed or left in place for extended periods.
  - Shall not be used on paved surfaces.
  - Shall not to be used for drain inlet protection or in areas of concentrated flow.
  - May introduce undesirable non-native plants to the area or be an attractive food source for some animals (see Permits in Section 7-5 of the contract Special Provisions).

**Standards and Specifications**     **Materials**

- **Straw Bale Size:** Each straw bale shall be a minimum of 14 in. wide, 18 in. in height, 36 in. in length and shall have a minimum mass of 51 lb. The straw bale shall be composed entirely of vegetative matter, except for the binding material.
- **Bale Bindings:** Bales shall be bound by either steel wire, nylon or polypropylene string placed horizontally. Jute and cotton binding shall not be used. Baling wire shall be a minimum diameter of 14 gauge. Nylon or polypropylene string shall be approximately 12 gauge in diameter with a breaking strength of 80 lbs. force.
- **Stakes:** Wood stakes shall be commercial quality lumber of the size and shape shown on the plans. Each stake shall be free from decay, splits or cracks longer than the thickness of the stake, or other defects that would weaken the stakes and cause the stakes to be structurally unsuitable. Steel bar reinforcement shall be equal to a number four designation or greater. End protection shall be provided for any exposed bar reinforcement.

**Installation**

- Limit the drainage area upstream of the barrier to 0.25 ac/100ft of barrier.
- Limit the slope length draining to the straw bale barrier to 100 ft.
- Slopes of 2:100 (V:H) (2%) or flatter are preferred. If the slope exceeds 1:10 (V:H) (10%), the length of slope upstream of the barrier must be less than 50 ft.
- Install straw bale barriers along a level contour, with the last straw bale turned up slope.

- Straw bales must be installed in a trench and tightly abut adjacent bales.
- Install straw bale barriers with a set-back of at least 3 ft from the toe of a slope. Where it is determined to be not practical due to specific site conditions, the straw bale barrier may be constructed at the toe of the slope, but shall be constructed as far from the toe of the slope as practical.
- Install straw bale barriers per pages 4 and 5 of this BMP for installation detail.

## Maintenance and Inspection

- Ensure that all perimeter controls are maintained and protected from activities that reduce their effectiveness.
- Inspect all straw bale barriers weekly and before and after every rainfall events. During extended rainfall events, inspect straw bale barriers at least once every 24 hours.
- Inspect straw bale barriers for sediment accumulations and remove sediment when depth reaches one-third the barrier height. Removed sediment shall be incorporated in the project at locations designated by the Engineer or disposed of outside the right-of-way in conformance with all applicable laws and regulations.
- Replace or repair damage bales as needed or as directed by the Engineer.
- Repair washouts or other damages as needed or as directed by the Engineer.
- Remove straw bales when no longer needed. Remove sediment accumulation, and clean, re-grade, and stabilized the area.

# Straw Bale Barrier

SC-9

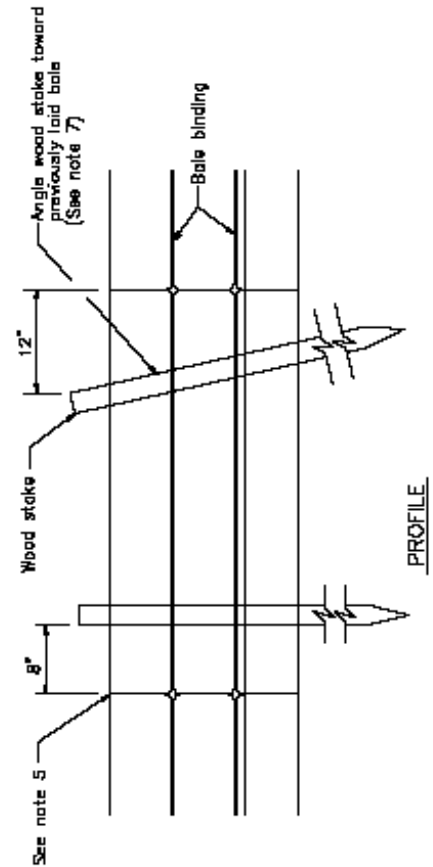
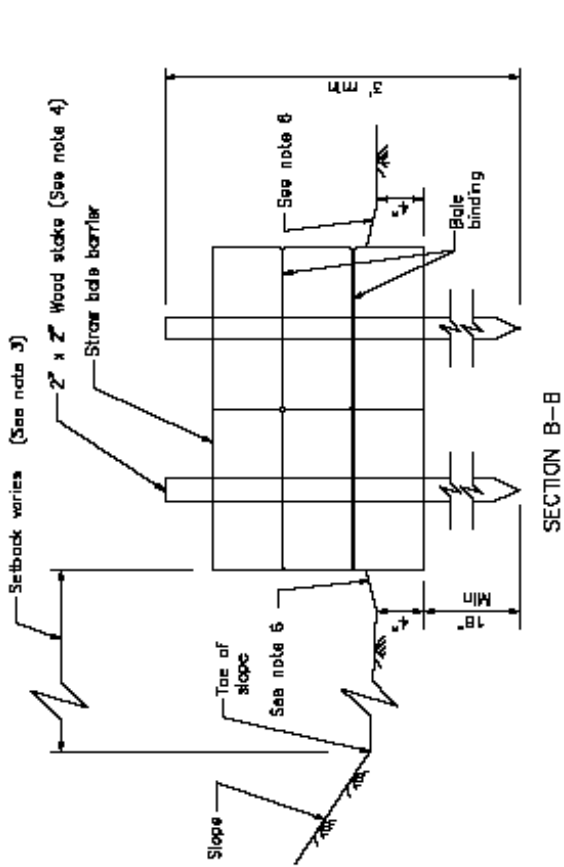

LEGEND  
DIRECTION OF FLOW

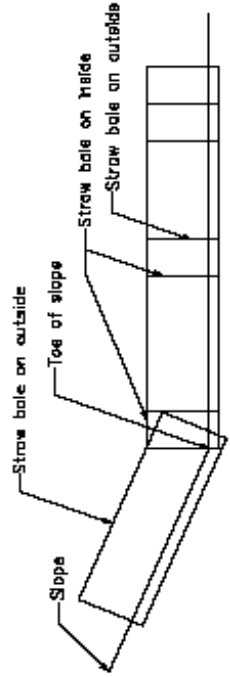

END DETAIL

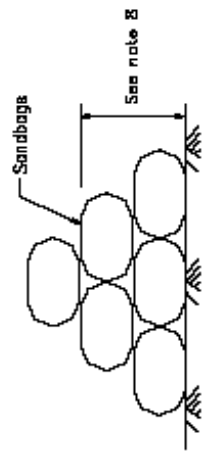

SANDBAG CROSS BARRIER





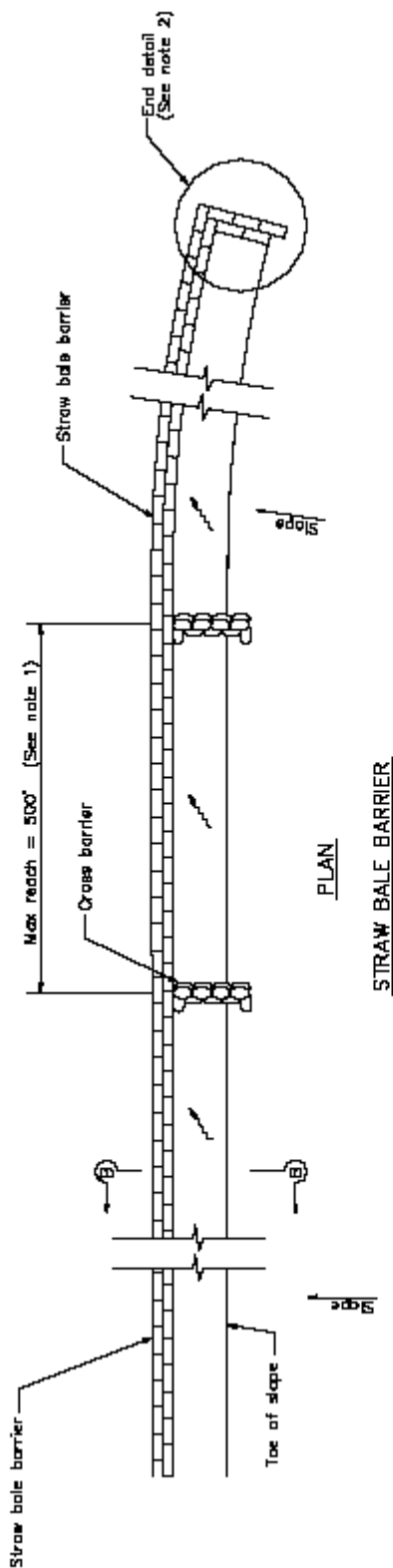

**NOTES**

1. Construct the length of each reach so that the change in base elevation along the reach does not exceed 1/2 the height of the linear barrier. In no case shall the reach length exceed 500'.
2. The end of barrier shall be turned up slope.
3. Dimension may vary to fit field condition.
4. Stake dimensions are nominal.
5. Place straw bales tightly together.
6. Tamp embedment spalls against sides of installed bales.
7. Drive angled wood stake before vertical stake to ensure tight abutment to adjacent bale.
8. Sandbag cross barriers should be a min of 1/2 and a max of 2/3 the height of the linear barrier.
9. Sandbag rows and layers should be offset to eliminate gaps.

**LEGEND**

-----> DIRECTION OF FLOW

(This page left intentionally blank)

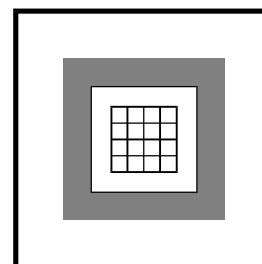
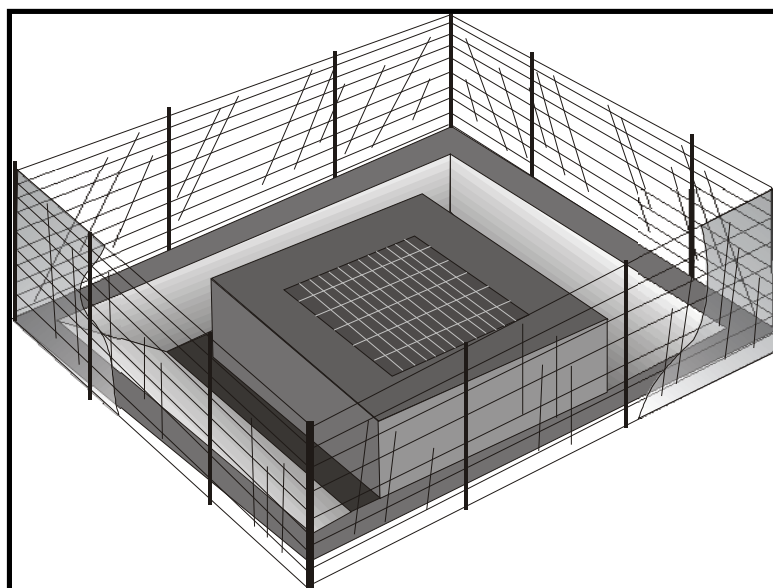

Standard Symbol

- BMP Objectives**

  - Soil Stabilization
  - Sediment Control
  - Tracking Control
  - Wind Erosion Control
  - Non-Storm Water Management
  - Materials and Waste Management

**Definition and Purpose** Storm drain inlet protection includes devices used at storm drain inlets that are subject to runoff from construction activities to detain and/or filter sediment-laden runoff to allow sediment to settle and/or to filter sediment prior to discharge into storm drainage systems or watercourses.

- Appropriate Applications**
- Where ponding will not encroach into roadway traffic.
  - Where sediment laden surface runoff may enter an inlet.
  - Where disturbed drainage areas have not yet been permanently stabilized.
  - Required to be implemented on a year around basis.

- Limitations**
- Not a stand-alone BMP. Storm Drain Inlet Protection shall always be implemented with other erosion and sediment controls upgradient.
  - Requires an adequate area for water to pond without encroaching upon traveled way and shall not be an obstacle to oncoming traffic.
  - Other methods of temporary protection are required to prevent non-storm water discharges from entering the storm drain system.
  - Sediment removal may be difficult in high flow conditions or if runoff is heavily sediment laden. If high flow conditions are expected, use other on-site sediment trapping techniques (e.g. check dams) in conjunction with inlet protection.
  - For drainage areas larger than 1 ac, runoff shall be routed to a sediment trapping device designed for larger flows. See BMPs SC-2, “Sediment/Desilting Basin,” and SC-3 “Sediment Trap.”
  - Filter fabric fence inlet protection is appropriate in open areas that are subject to sheet flow and for flows not exceeding 0.5 cfs.

- Gravel bag barriers for inlet protection are applicable when sheet flows or concentrated flows exceed 0.5 cfs, and it is necessary to allow for overtopping to prevent flooding.
- Fiber rolls and foam barriers are not appropriate for locations where they cannot be properly anchored to the surface.
- Excavated drop inlet sediment traps are appropriate where relatively heavy flows are expected and overflow capability is needed.

**Standards and Specifications** Identify existing and/or planned storm drain inlets that have the potential to receive sediment-laden surface runoff. Determine which method to use.

### **Methods and Installation**

- **DI Protection Type 1 - Filter Fabric Fence** - The filter fabric fence (Type 1) protection is illustrated on Page 5. It is similar to constructing a silt fence. See BMP SC-1, "Silt Fence." Do not place filter fabric underneath the inlet grate since the collected sediment may fall into the drain inlet when the fabric is removed or replaced.
- **DI Protection Type 2 - Excavated Drop Inlet Sediment Trap** - The excavated drop inlet sediment trap (Type 2) is illustrated in Page 6. It is similar to constructing a temporary silt fence, See BMP SC-1, "Silt Fence." Size excavated trap to provide a minimum storage capacity calculated at the rate of 67 yd<sup>3</sup>/ac of drainage area.
- **DI Protection Type 3 – Gravel bag** - The gravel bag barrier (Type 3) is illustrated in Page 7. Flow from a severe storm shall not flow over the curb. In areas of high clay and silts, use filter fabric and gravel as additional filter media. Construct gravel bags in accordance with BMP SC-6, "Gravel Bag Berm." Gravel bags shall be used due to their high permeability.
- **DI Protection Type 4 – Block and Gravel Filter – The block and gravel filter** (Type 4) is placed around the inlet as illustrated in Page 8. Block and gravel filters are suitable for curb inlets commonly used in residential, commercial, and industrial construction. Engineer approval is required.
- **DI Protection Type 5 – Foam Barriers and Fiber Rolls** – Foam barrier or fiber roll (Type 5) is placed around the inlet and keyed and anchored to the surface. Foam barriers and fiber rolls are intended for use as inlet protection where the area around the inlet is unpaved and the foam barrier or fiber roll can be secured to the surface. Engineer approval is required.

**Maintenance and Inspection** **General**

- Inspect all inlet protection devices weekly and before and after every rainfall events. During extended rainfall events, inspect inlet protection devices at least once every 24 hours.

- Ensure that all storm drain inlets are maintained and protected from activities that reduce their effectiveness.
- Remove all inlet protection devices within thirty days after the site is stabilized, or when the inlet protection is no longer needed.
  - Bring the disturbed area to final grade and smooth and compact it. Appropriately stabilize all bare areas around the inlet.
  - Clean and re-grade area around the inlet and clean the inside of the storm drain inlet as it must be free of sediment and debris.

## **Requirements by Method**

### ■ ***Type 1 - Filter Fabric Fence***

This method shall be used for drain inlets requiring protection in areas where finished grade is established and erosion control seeding has been applied or is pending.

- Make sure the stakes are securely driven in the ground and are structurally sound (i.e., not bent, cracked, or splintered, and are reasonably perpendicular to the ground). Replace damaged stakes.
- Replace or clean the fabric when the fabric becomes clogged with sediment. Make sure the fabric does not have any holes or tears. Repair or replace fabric as needed or as directed by the Engineer.
- At a minimum, remove the sediment behind the fabric fence when accumulation reaches one-third the height of the fence or barrier height. Removed sediment shall be incorporated in the project at locations designated by the Engineer or disposed of outside the right-of-way in conformance with all applicable laws and regulations.

### ■ ***Type 2 - Excavated Drop Inlet Sediment Trap***

This method may be used for drain inlets requiring protection in areas that have been cleared and grubbed, and where exposed soil areas are subject to grading.

- Remove sediment from basin when the volume of the basin has been reduced by one-third.

### ■ ***Type 3 - Gravel Bag Barrier***

This method may be used for drain inlets surrounded by AC or paved surfaces.

- Inspect bags for holes, gashes, and snags.
- Check gravel bags for proper arrangement and displacement. Remove the sediment behind the barrier when it reaches one-third the height of the barrier. Removed sediment shall be incorporated in the project at locations designated by the Engineer or disposed of in conformance with applicable laws and regulations.

## ■ *Type 4 -Block and Gravel Filter*

The block and gravel filter (Type 4) is shown in the figures. Block and gravel filters are suitable for curb inlets commonly used in residential, commercial, and industrial construction.

- Place hardware cloth or comparable wire mesh with 0.5 in. openings over the drop inlet so that the wire extends a minimum of 1 ft beyond each side of the inlet structure. If more than one strip is necessary, overlap the strips. Place filter fabric over the wire mesh.
- Place concrete blocks lengthwise on their sides in a single row around the perimeter of the inlet, so that the open ends face outward, not upward. The ends of adjacent blocks should abut. The height of the barrier can be varied, depending on design needs, by stacking combinations of blocks that are 4 in., 8 in., and 12 in. wide. The row of blocks should be at least 12 in. but no greater than 24 in. high.
- Place wire mesh over the outside vertical face (open end) of the concrete blocks to prevent stone from being washed through the blocks. Use hardware cloth or comparable wire mesh with 0.5 in. opening.
- Pile washed stone against the wire mesh to the top of the blocks. Use 0.75 to 3 in.

## ■ *Type 5 Foam Barriers and Fiber Rolls*

This method may be used for drain inlets requiring protection in areas that have been cleared and grubbed, and where exposed soil areas subject to grading. Engineer approval is required.

- Check foam barrier or fiber roll for proper arrangement and displacement. Remove the sediment behind the barrier when it reaches one-third the height of the barrier. Removed sediment shall be incorporated in the construction site at locations designated by the Engineer or disposed of in conformance with all applicable laws and regulations.

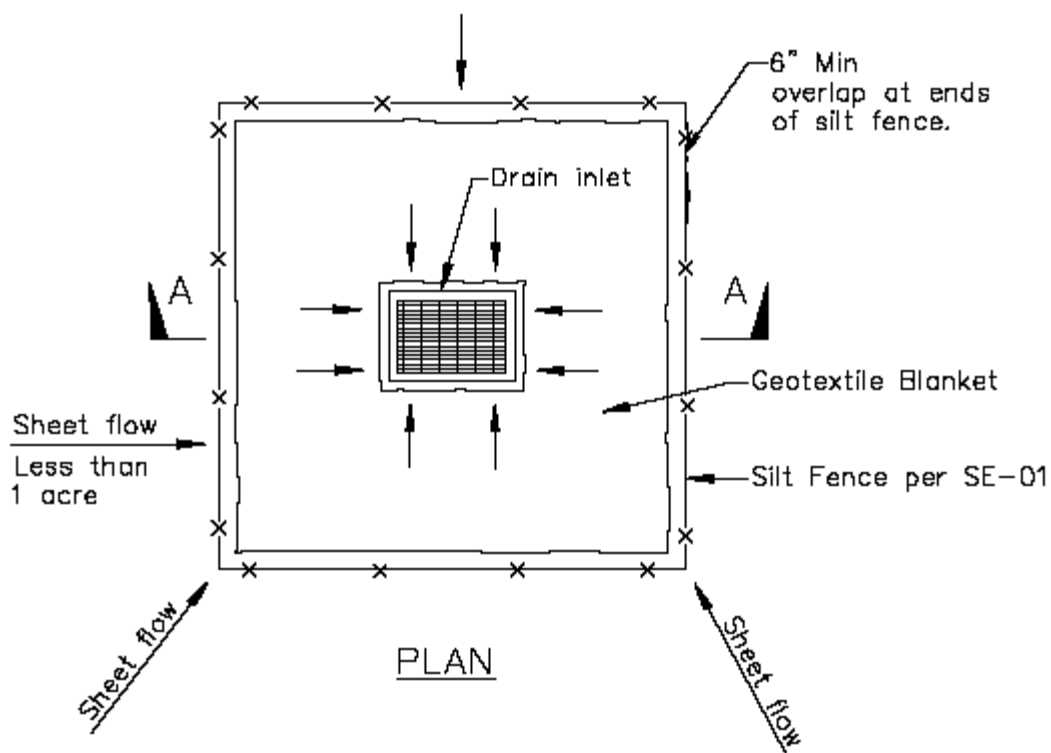
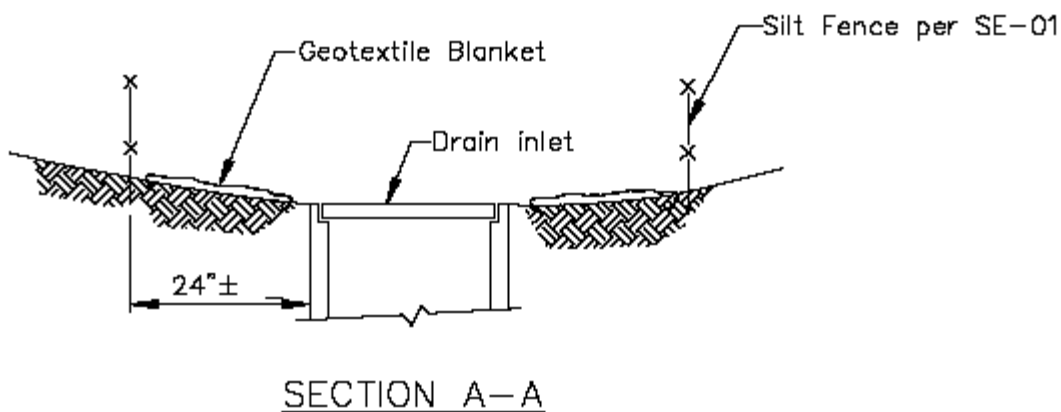

DI PROTECTION TYPE 1  
NOT TO SCALE

**NOTES:**

1. For use in areas where grading has been completed and final soil stabilization and seeding are pending.
2. Not applicable in paved areas.
3. Not applicable with concentrated flows.

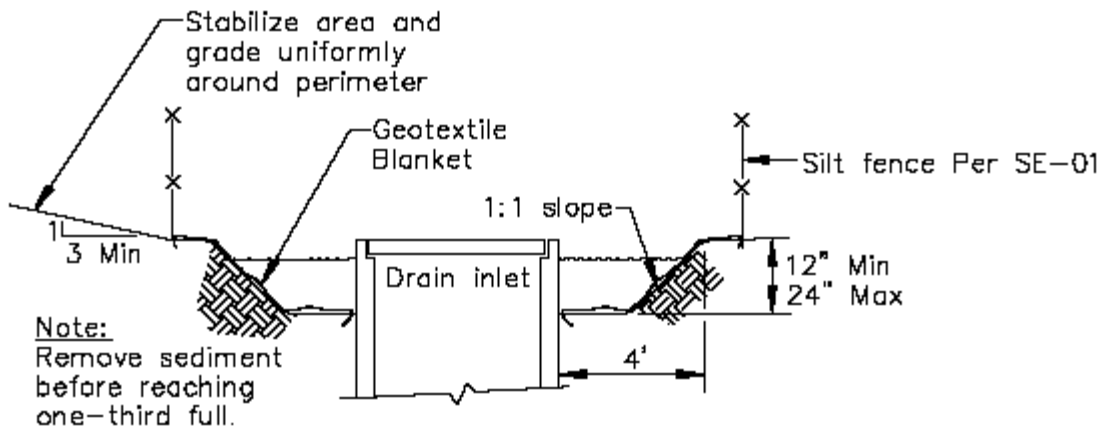

Section A-A

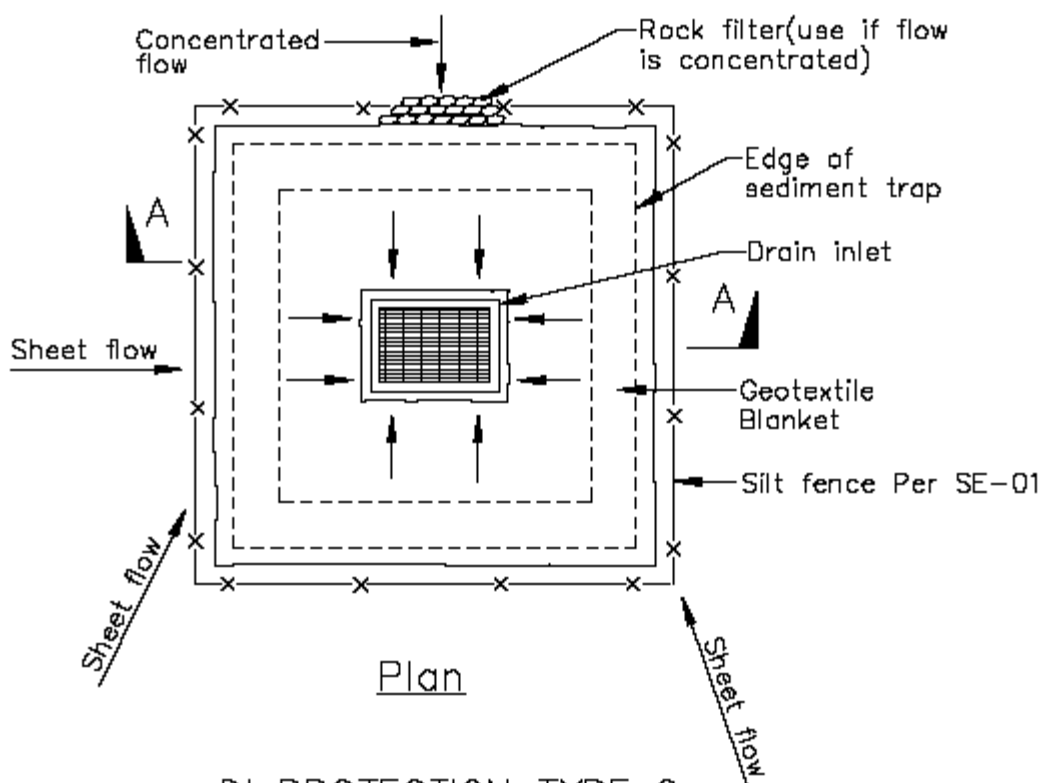

Plan

DI PROTECTION TYPE 2  
NOT TO SCALE

### Notes

1. For use in cleared and grubbed and in graded areas.
2. Shape basin so that longest inflow area faces longest length of trap.
3. For concentrated flows, shape basin in 2:1 ratio with length oriented towards direction of flow.



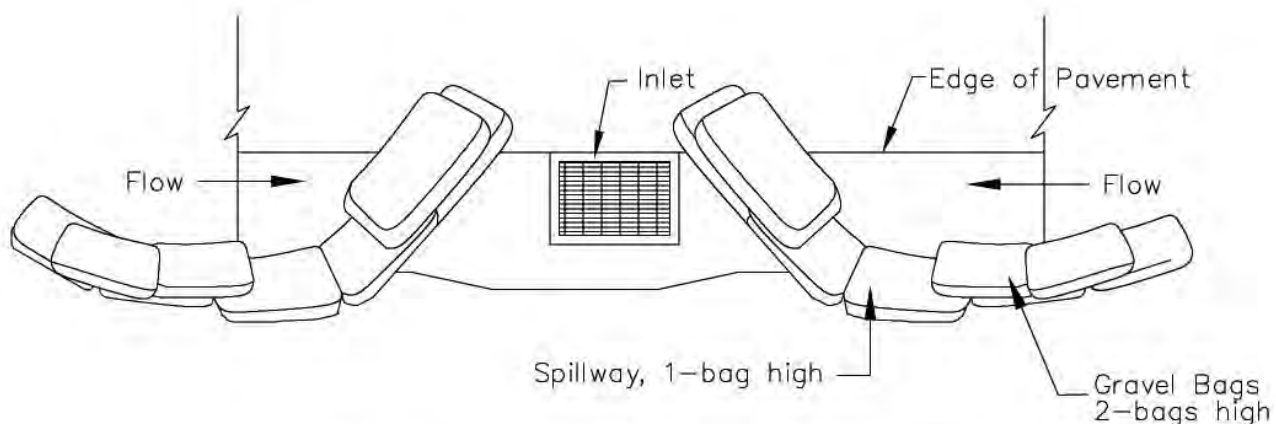

**TYPICAL PROTECTION FOR INLET WITH OPPOSING FLOW DIRECTIONS**

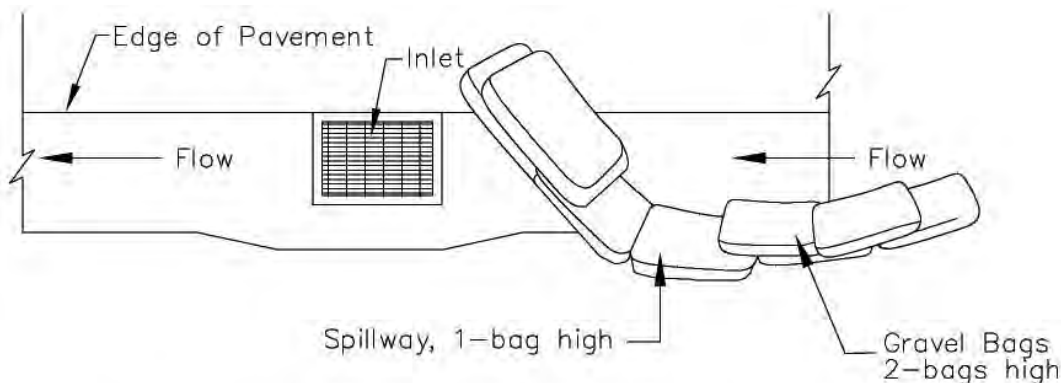

**TYPICAL PROTECTION FOR INLET WITH SINGLE FLOW DIRECTION**

**NOTES:**

1. Intended for short-term use.
2. Use to inhibit non-storm water flow.
3. Allow for proper maintenance and cleanup.
4. Bags must be removed after adjacent operation is completed
5. Not applicable in areas with high silts and clays without filter fabric.

**DI PROTECTION - TYPE 3**

**Not to scale**

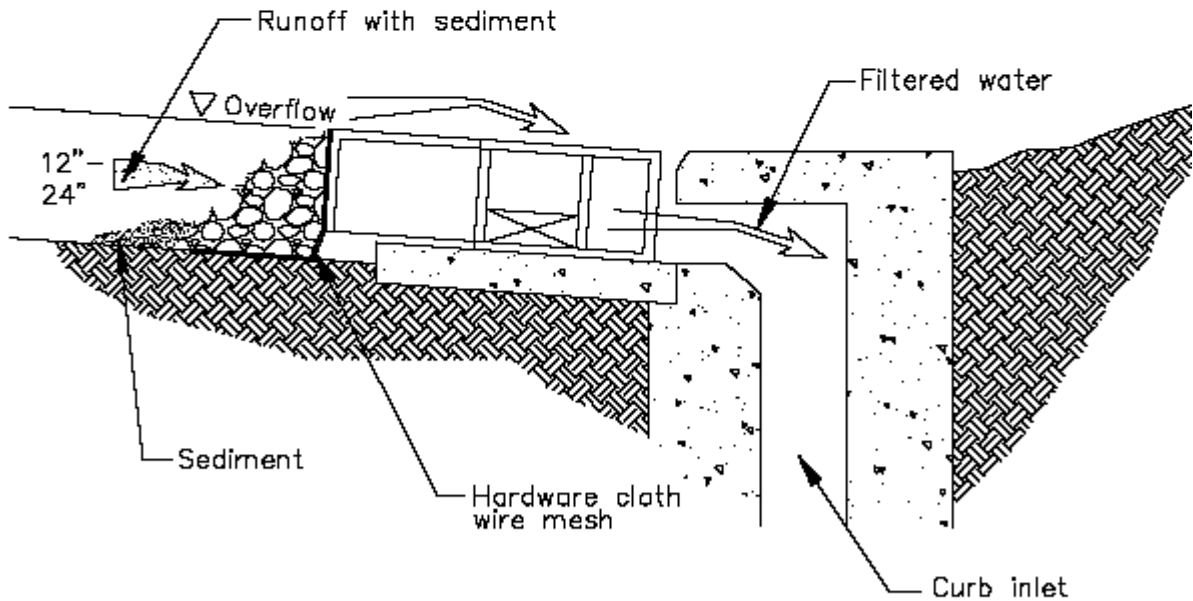
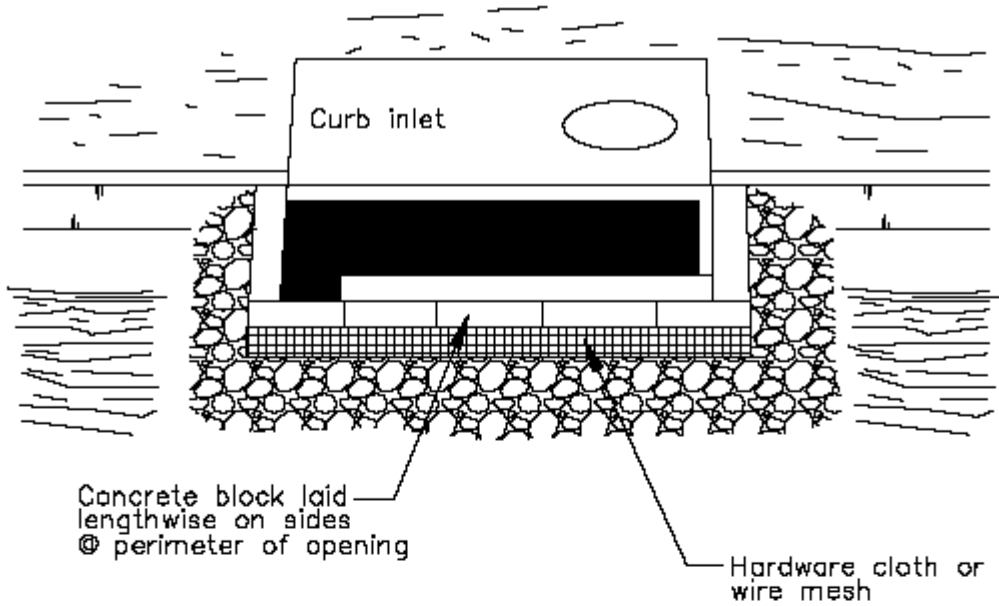

DI PROTECTION - TYPE 4  
NOT TO SCALE



## SECTION 5

### WIND EROSION CONTROL BMPs

Wind erosion control consists of applying water or dust palliatives, covering or other control method approved by the Engineer to prevent or alleviate wind erosion, dust nuisance and prevent sediment from leaving the construction site. It is recognized that soil stabilization BMPs are also effective as wind erosion control (i.e., hydromulch, hydroseeding, soil binders, straw mulch, geotextiles, plastic covers, wind erosion control blankets/mats, wood mulch). Implementation of effective wind erosion controls is required. Wind erosion control BMPs are shown on Table5-1.

<b>Table 5-1 Wind Erosion Control BMPs</b>	
<b>ID</b>	<b>BMP Name</b>
WE-1	Wind Erosion Control

(This page left intentionally blank)

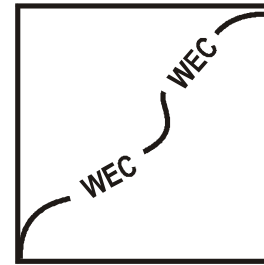
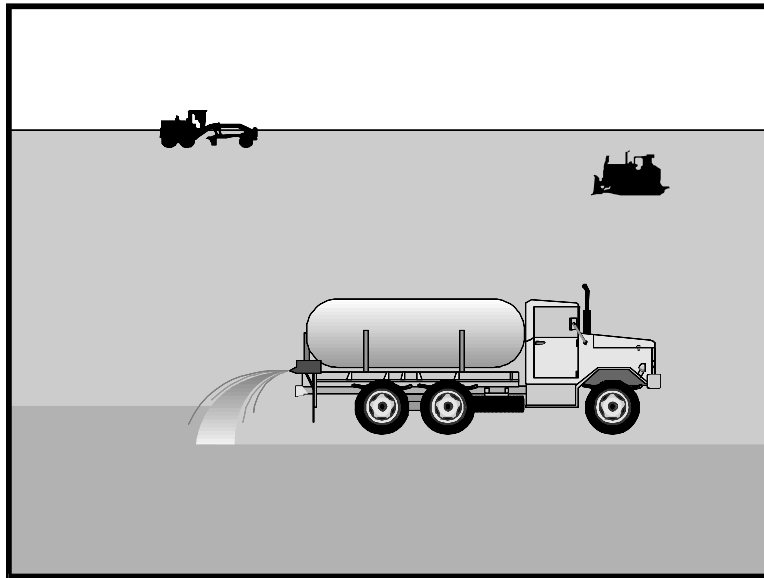

Standard Symbol

- BMP Objectives**

  - Soil Stabilization
  - Sediment Control
  - Tracking Control
  - Wind Erosion Control
  - Non-Storm Water Management
  - Materials and Waste Management

**Definition and Purpose** Wind erosion control consists of applying water and/or other dust palliatives as necessary to prevent or alleviate erosion by the forces of wind. Covering of all stockpiles is required year round.

**Appropriate Applications** This practice is implemented on all exposed soils subject to wind erosion.

- Standards and Specifications**
- Effective wind erosion control shall be implemented.
  - Implement good housekeeping measures on the construction site to control the air deposition of site materials and from site operations. Such particulates can include, but are not limited to, sediment, nutrients, trash, metals, bacteria, oil and grease and organics.
  - Water shall be applied by means of pressure-type distributors or pipelines equipped with a spray system or hoses and nozzles that will ensure even distribution.
  - All distribution equipment shall be equipped with a positive means of shutoff.
  - Unless water is applied by means of pipelines, at least one mobile unit shall be available at all times to apply water or dust palliative to the project.
  - If reclaimed water is used, the sources and discharge must meet California Department of Health Services water reclamation criteria and the Regional Water Quality Control Board requirements. Non-potable water shall not be conveyed in tanks or drain pipes that will be used to convey potable water and there shall be no connection between potable and non-potable supplies. Non-potable tanks, pipes and other conveyances shall be marked “NON-POTABLE WATER - DO NOT DRINK.”
  - Soil stabilization BMPs are also effective as wind erosion control (SS-3, SS-4, SS-5, SS-6, SS-7, and SS-8).

## Maintenance and Inspection

- Inspect wind erosion control measures daily and document weekly.
- Check areas that have been protected to ensure coverage and effectiveness of Wind erosion controls. If wind erosion or dust are observed, Contractor shall immediately reapply or implement additional wind erosion control BMPs.



# SECTION 6

## TRACKING CONTROL BMPs

Tracking control consists of preventing or reducing vehicle and equipment tracking of sediment and other debris onto paved surfaces and preventing sediment from entering the storm drain system or watercourses. Sediment control for Street Sweeping and Vacuuming is also recognized as a tracking control BMP. However, street sweeping and vacuuming is not allowed as a stand-alone BMP for tracking control. Tracking control BMPs are shown on Table 6-1.

<b>Table 6-1</b>	
<b>Tracking Control BMPs</b>	
<b>ID</b>	<b>BMP Name</b>
TC-1	Stabilized Construction Entrance/Exit
TC-2	Stabilized Construction Roadway
TC-3	Entrance/Outlet Tire Wash

(This page left intentionally blank)



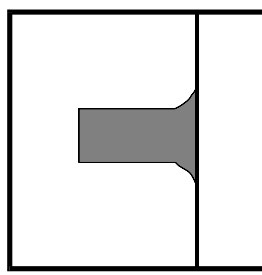
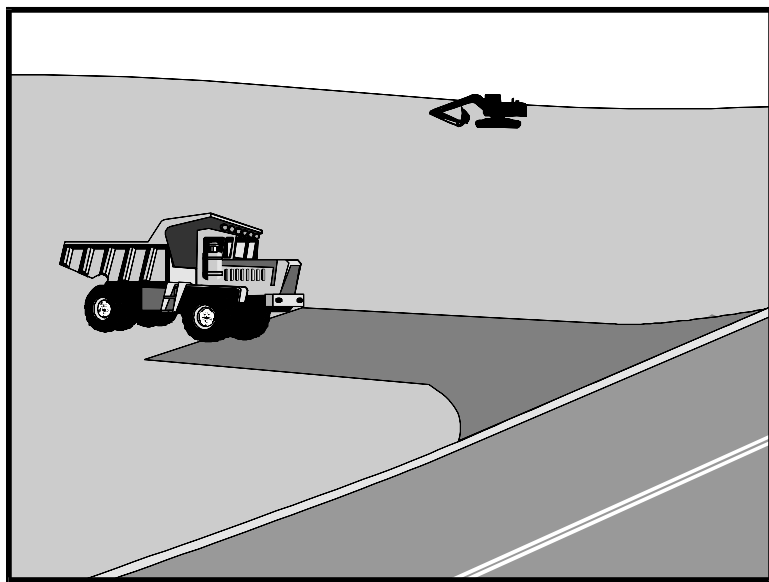

Standard Symbol

- BMP Objectives**

  - Soil Stabilization
  - Sediment Control
  - Tracking Control
  - Wind Erosion Control
  - Non-Storm Water Management
  - Materials and Waste Management

**Definition and Purpose** A stabilized construction access is defined by a point of entrance/exit to a construction site that is stabilized to reduce the tracking of mud and dirt onto all paved surfaces and paved private and public roads by construction vehicles.

- Appropriate Applications**
- Use at all construction sites:
    - Where dirt or mud can be tracked onto paved surfaces or paved private or public roads.
    - Adjacent to water bodies.
    - Where poor soils are encountered.
    - Where dust is a problem during dry weather conditions.
  - This BMP shall be implemented on all construction sites.

**Limitations** ■ None identified

- Standards and Specifications**
- Stabilize all construction entrances and exits to the construction site.
  - Ensure that construction activity traffic to and from the project is limited to entrances and exits that employ effective controls to prevent offsite tracking of sediment.
  - Prevent the off-site tracking of loose construction and landscape materials.
  - Limit speed of vehicles to control dust.
  - Properly grade each construction entrance/exit to prevent runoff from leaving the construction site.
  - Route runoff from stabilized entrances/exits through a sediment-trapping device before discharge.



- Design stabilized entrance/exit to support the heaviest vehicles and equipment that will use it.
- Select construction access stabilization (aggregate, asphaltic concrete, concrete) based on longevity, required performance, and site conditions. The use of asphalt concrete (AC) grindings for stabilized construction access/roadway is not allowed.
- Use of constructed/manufactured steel plates with ribs for entrance/exit access is allowed with written approval from the Engineer.
- Place crushed aggregate over geotextile fabric to at least 12 in. depth, or place aggregate to a depth recommended by the Engineer. Crushed aggregate greater than 3 inches and smaller than 6 inches shall be used.
- Designate combination or single purpose entrances and exits to the construction site.
- Implement BMP SC-7, “Street Sweeping and Vacuuming” as needed and as required.
- Require all employees, subcontractors, and suppliers to utilize the stabilized construction access.

## Maintenance and Inspection

- Ensure that all pollutant controls at entrances and exits are maintained and protected from activities that reduce their effectiveness.
- Inspect all entrances, exits, access roads daily and document weekly, and before and after every rainfall events. During extended rainfall events, inspect all entrances, exits, access roads at least once every 24 hours.
- Remove any sediment or other construction activity related materials that are deposited on the roads (by sweeping and vacuuming).
- Remove aggregate, separate and dispose of sediment if construction entrance/exit is clogged with sediment or as directed by the Engineer.

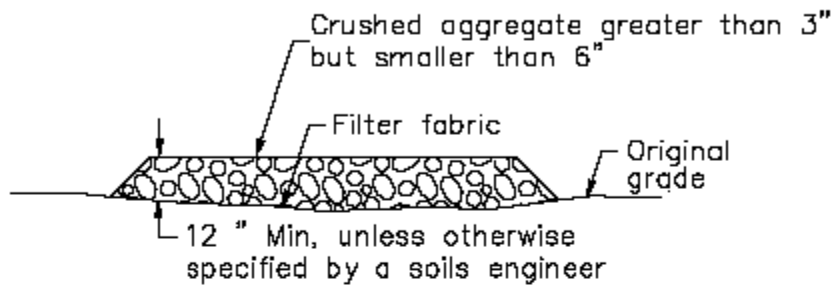

SECTION B-B  
NTS

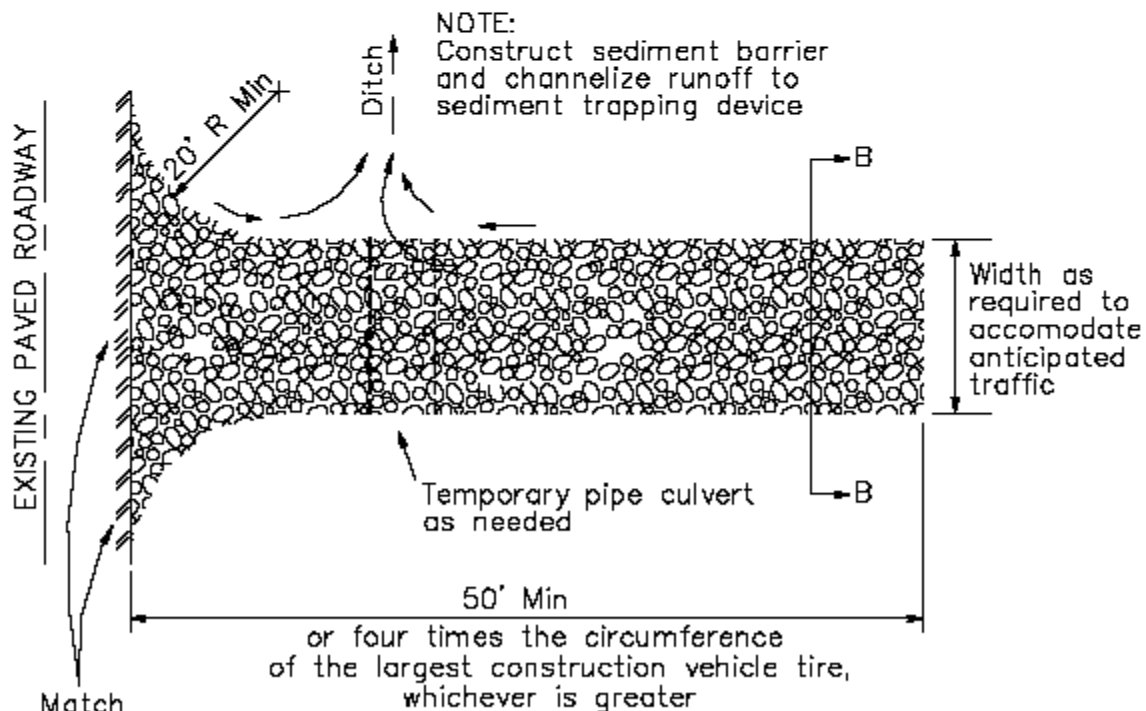

PLAN  
NTS

Stabilized Construction Entrance/Exit (Type 1)

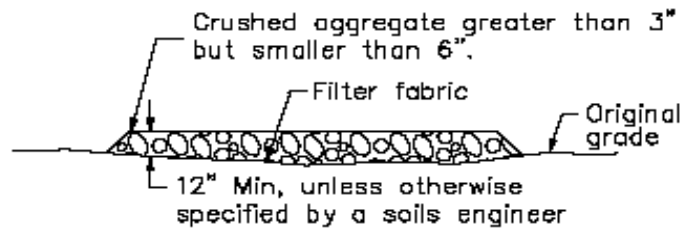

**SECTION B-B**  
NTS

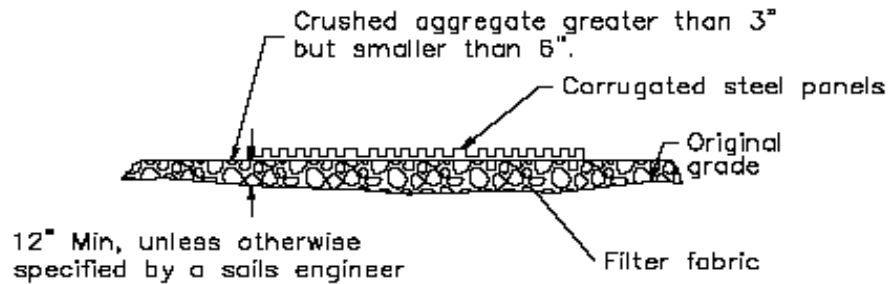

**SECTION A-A**  
NOT TO SCALE

NOTE:  
Construct sediment barrier and channelize runoff to sediment trapping device

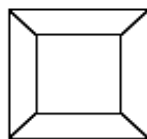

Sediment trapping device

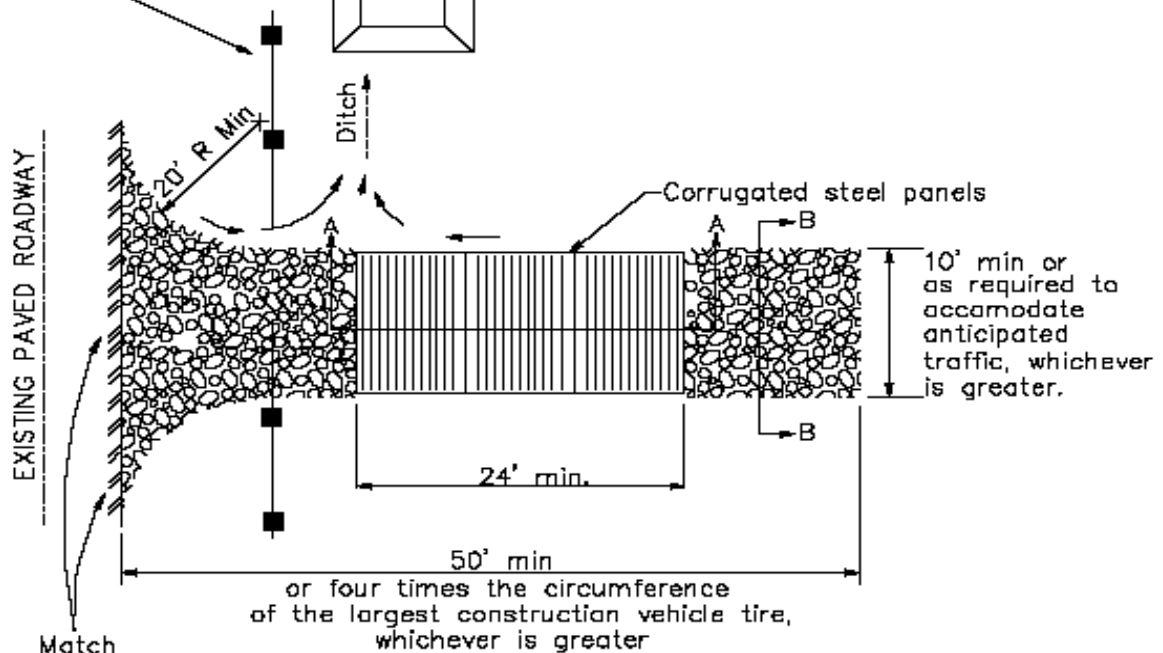

**PLAN**  
NTS

Stabilized Construction Entrance/Exit (Type 2)

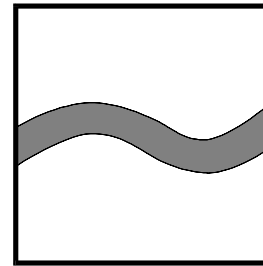
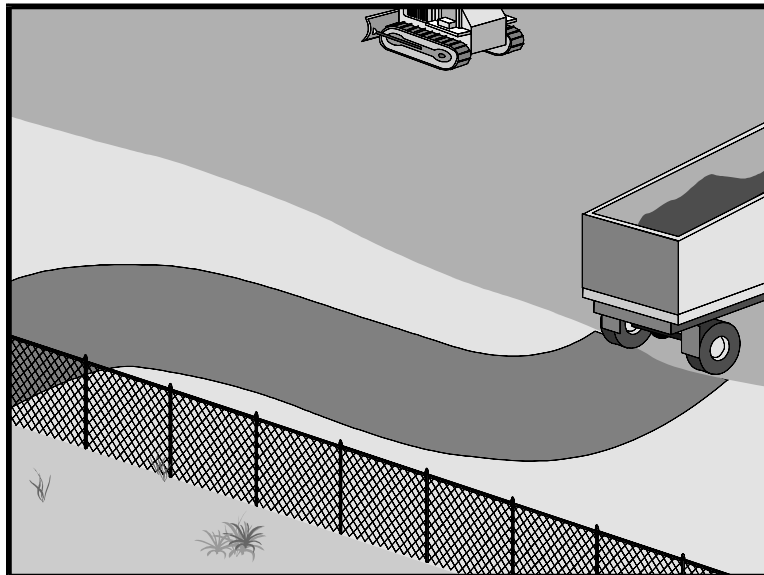

Standard Symbol

### BMP Objectives

- Soil Stabilization
- Sediment Control
- Tracking Control
- Wind Erosion Control
- Non-Storm Water Management
- Materials and Waste Management

**Definition and Purpose** A stabilized construction roadway is a temporary access road. It is designed for the control of dust and erosion created by vehicular tracking.

- Appropriate Applications**
- Construction roadways and short-term detour roads:
    - Where tracking is a problem.
    - Where dust is a problem.
    - Adjacent to water bodies.
    - Where poor soils are encountered.
    - Where there are steep grades and additional traction is needed.

**Limitations** None identified.

- Standards and Specifications**
- Properly grade roadway to prevent runoff from leaving the construction site.
  - Install NS-4 Temporary Stream Crossing as directed by the Engineer.
  - Design stabilized access to support the heaviest vehicles and equipment that will use it.
  - Stabilize roadway using aggregate, asphalt concrete, or concrete based on longevity, required performance, and site conditions. The use of cold mix asphalt or asphalt concrete (AC) grindings for stabilized construction roadway is not allowed.
  - If aggregate is selected, place crushed aggregate over geotextile fabric to at least 12 in. depth, or place aggregate to a depth recommended by the Engineer. Crushed aggregate greater than 3 inches and smaller than 6 inches shall be used.

## Maintenance and Inspection

- Properly grade roadway to prevent runoff from leaving the construction site.
- Limit speed of vehicles to control dust or as directed by the Engineer.
- Coordinate materials with those used for stabilized construction entrance/exit points.
- Inspect stabilized construction roadways weekly and before and after every rainfall events. During extended rainfall events, inspect stabilized construction roadways at least once every 24 hours.
- Keep all temporary roadway ditches clear.
- When no longer required, remove stabilized construction roadway and re-grade and repair slopes.

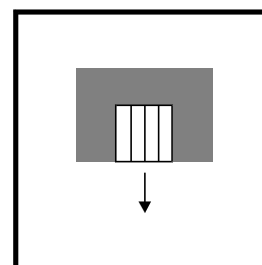

Standard Symbol

### BMP Objectives

- Soil Stabilization
- Sediment Control
- Tracking Control
- Wind Erosion Control
- Non-Storm Water Management
- Materials and Waste Management

- Definition and Purpose** A tire wash is an area located at stabilized construction access points to remove sediment tires and undercarriages, and to prevent sediment from being transported onto paved roadways.
- Appropriate Applications**
- Tire washes may be used on construction sites where dirt and mud tracking onto paved roads by construction vehicles may occur.
  - This BMP may be implemented on a project-by-project basis with other BMPs when determined necessary and feasible by the contract special provisions or Engineer.
- Limitations**
- Requires a supply of wash water.
  - The waste water shall not be disposed of onsite.
- Standards and Specifications**
- Incorporate with a stabilized construction entrance/exit. See BMP TC-1, “Stabilized Construction Entrance/Exit” and BMP SC-7, “Street Sweeping and Vacuuming”
  - Pre-constructed tire wash systems are available for purchase or lease.
  - Construct on level ground when possible, on a pad of coarse aggregate, greater than 3 inches and smaller than 6 inches. A geotextile fabric shall be placed below the aggregate.
  - The tire wash shall be designed and constructed/manufactured for anticipated traffic loads.
  - The tire wash shall be activated automatically upon vehicle’s approach.

- Tire Wash shall remove all dirt/mud and debris from the tires and tire-grooves, wheel wells and undercarriages of the vehicles.
- The water recycling system shall be capable of processing the water to sufficiently remove mud/silt and debris for re-use. The water shall be replaced as needed or as directed by the engineer.
- The tire wash shall perform so that no visible mud/silt or debris, dried or wet, is observed on the paved road after the tire wash.
- The tire wash shall perform so that no visible mud/silt and debris is observed on the truck tires or the undercarriage of the trucks after the tire wash
- Require all employees, subcontractors, and others that leave the site to use the wash facility.
- Implement BMP SC-7, "Street Sweeping and Vacuuming".

## Maintenance and Inspection

- Inspect tire wash weekly and before and after every rainfall events. During extended rainfall events, inspect tire wash at least once every 24 hours.
- Ensure that all pollutant controls at entrances and exits (e.g. tire wash off locations) are maintained and protected from activities that reduce their effectiveness.
- Remove accumulated sediment in wash rack and/or sediment trap to maintain system performance.



# Entrance/Outlet Tire Wash

**TC-3**

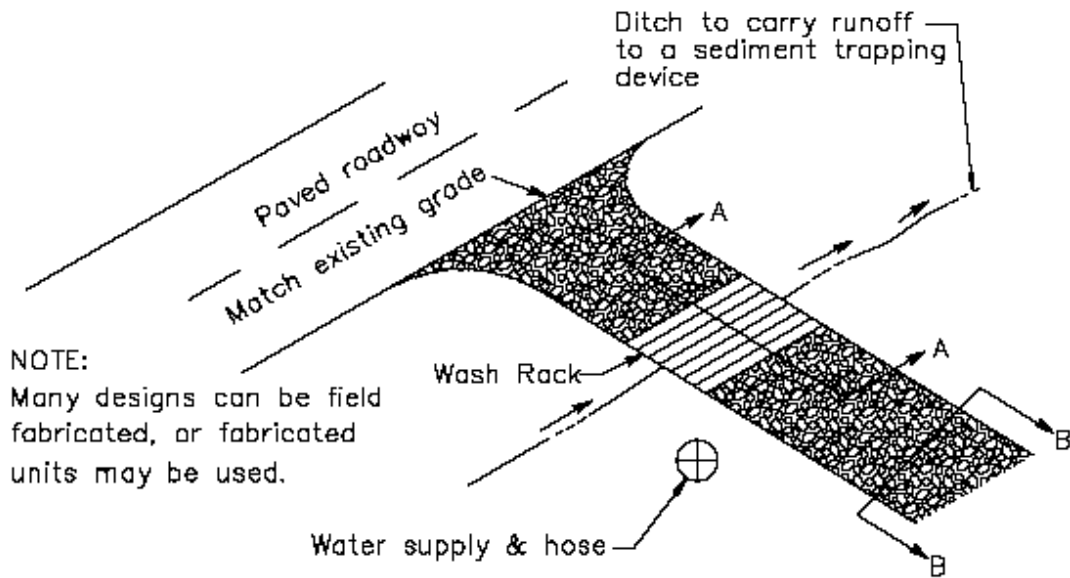
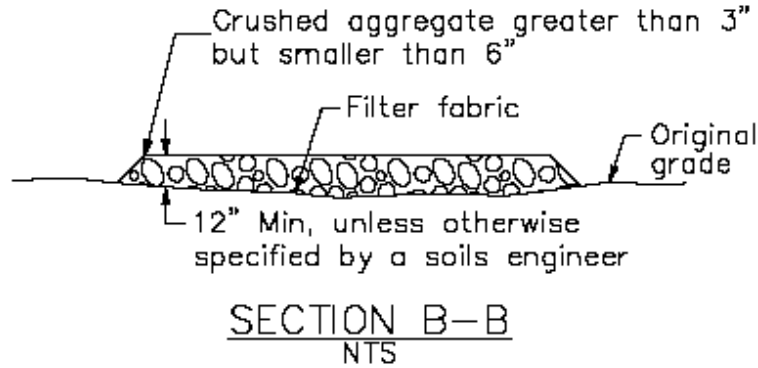
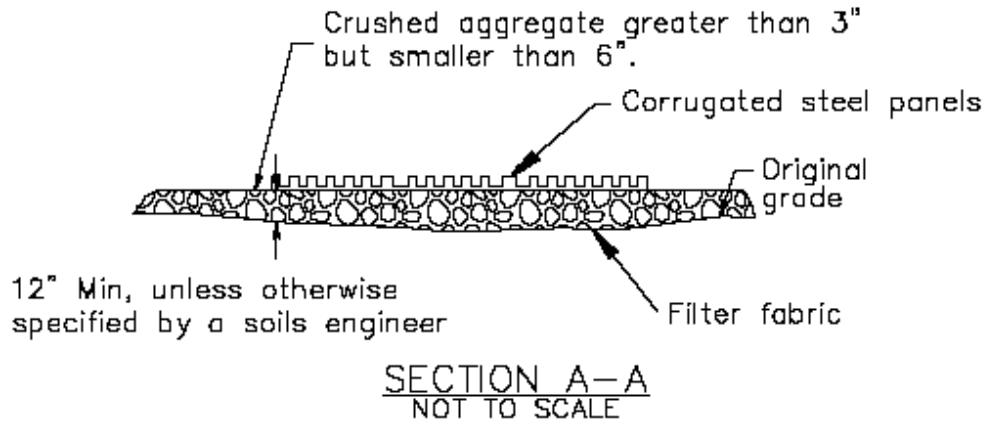

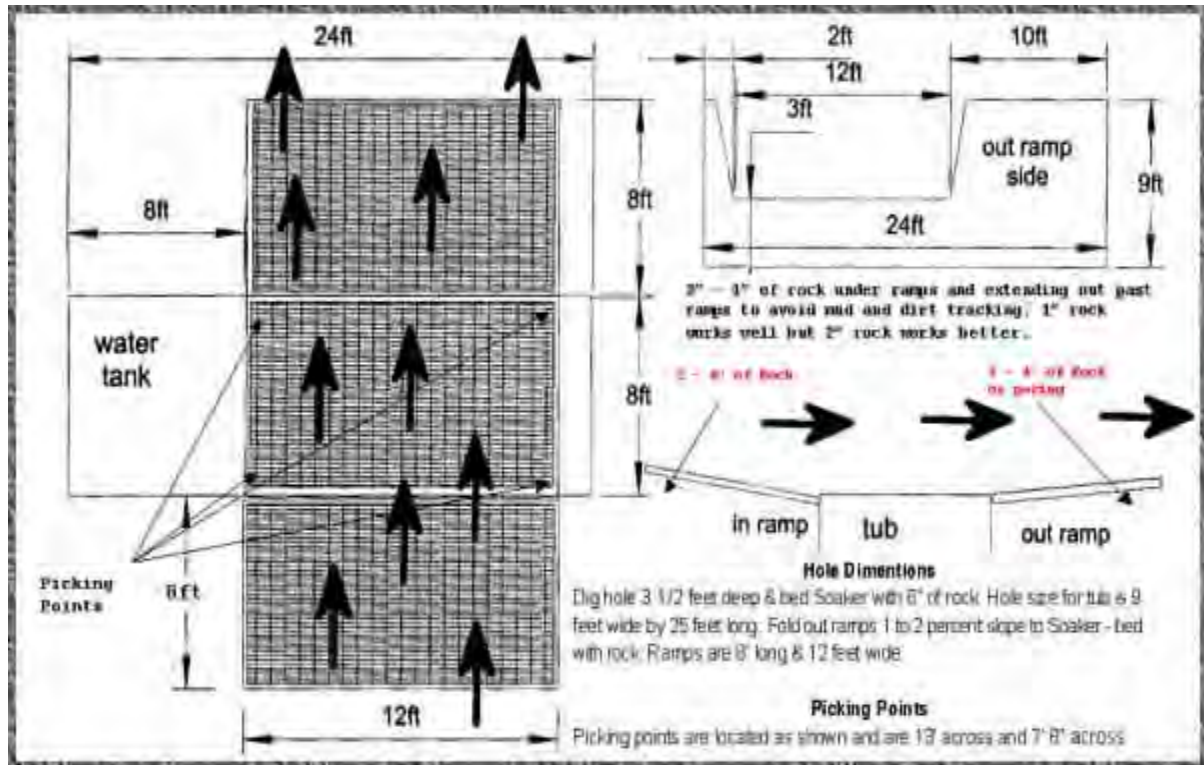

**Example Self-Contained Tire Washing System**

## SECTION 7

### NON-STORM WATER MANAGEMENT BMPs

The discharge of materials other than storm water and authorized non-storm water discharges are prohibited. Non-storm water management BMPs are source control BMPs that prevent pollution by limiting or preventing potential pollutants at the source, eliminating onsite and off-site discharge and discharge the ground. These non-storm water management BMPs are also referred to as “good housekeeping practices” which involve day-to-day operations of the construction site and contractor’s yard in order to maintain a clean, orderly, and safe construction site. Non-storm water management BMPs are shown on Table 7-1.

<b>ID</b>	<b>BMP Name</b>
NS-1	Water Conservation Practices
NS-2	Dewatering Operations (see Section 7.1 and 7.2)
NS-3	Paving and Grinding Operations
NS-4	Temporary Stream Crossing
NS-5	Clear Water Diversion
NS-6	Illicit Connection/Illegal Discharge Detection and Reporting
NS-7	Potable Water/Irrigation
NS-8	Vehicle and Equipment Cleaning
NS-9	Vehicle and Equipment Fueling
NS-10	Vehicle and Equipment Maintenance
NS-11	Pile Driving Operations
NS-12	Concrete Curing
NS-13	Material and Equipment Use Over Water
NS-14	Concrete Finishing
NS-15	Structure Demolition/Removal Over or Adjacent to Waters
NS-16	Temporary Batch Plant

#### 7.1 Construction Dewatering

All construction groundwater dewatering shall be in full compliance with the Monitoring and Reporting Program and Waste Discharge Requirements (WDR) of the NPDES permit included in the contract Special Provisions, if applicable. All Contractor operations shall be in full compliance with all applicable laws and regulations that govern water quality.

If groundwater is encountered on the construction site and the contract Special Provisions do **not** include provisions for construction dewatering **and** an NPDES permit from the RWQCB, the Contractor shall immediately notify the Engineer for direction. No groundwater shall be discharged to the sanitary sewer system, street/gutter, ground or any other location, whether contaminated, treated, or not, until approved by the Engineer. A construction dewatering plan in accordance with contract Special Provisions and NPDES Permit issued by the RWQCB, must be submitted to the Engineer for approval, prior to any dewatering discharge.

## 7.2 Accumulated Precipitation

Accumulated precipitation can be water from rain or snow melt. Accumulated precipitation on the construction site shall be managed in order to minimize the discharge of pollutants (mainly sediment) from entering the storm drain system.

The Contractor shall submit an Accumulated Precipitation Procedure (APP) detailing methods and procedures for management and discharge of accumulated precipitation on the construction site (contract Special Provisions 7-8.6). The APP shall include a description of: treatment technologies/BMPs, equipment, and discharge locations. The APP shall describe other pertinent information including: areas expected to accumulate precipitation, BMPs to protect accumulated precipitation from becoming sediment laden, inspection of accumulated precipitation prior to discharge, notification to the Engineer before any discharge of precipitation, options for not discharging precipitation, inspection, maintenance and repair procedures, and APP amendments.

If a SWPPP is required for the project per the contract Special Provisions (7-8.6.3), the APP shall be included in Attachment K of the SWPPP. If a SWPPP is not required per the contract Special Provisions, the Contractor shall prepare an APP and submit it to the Engineer separately in accordance with contract Special Provision Section 7-8.6.2.

The Contractor shall follow the procedures identified in NS-2 Dewatering Operations BMPs for the treatment of accumulated precipitation. The controls identified in BMP NS-2 Dewatering Operations are for sediment only. If the accumulated precipitation is determined or suspected to have come into contact with any pollutants other than sediment, the Contractor shall not discharge or immediately terminate discharge, and notify the Engineer for direction.

Accumulated precipitation that has been mixed with groundwater shall be managed as groundwater (see Section 7.1 Construction Dewatering). Accumulated precipitation, that has been mixed with non-storm water, shall be managed the same as the non-storm water in accordance with WM-10 Liquid Waste Management BMPs.

See the following example for a SWPPP project. After the example, see the required text for preparation of an APP for all projects.

**EXAMPLE: (for SWPPP Project)**

## Accumulated Precipitation Procedure (APP)

Project Name: \_\_\_\_\_

Project ID/ID Number: \_\_\_\_\_

 SWPPP required for this project       SWPPP not required for this project

This project may accumulate precipitation due to low lying areas, planned excavations or other construction-related water trapping equipment or materials. No accumulated water will be discharged without implementing this accumulated precipitation procedure (APP).

### Areas Expected to Trap Precipitation

The planned excavation areas for this project include the roadway areas, parking lots, alleys, sidewalks and roadway medians where the existing asphalt concrete will be removed and where the shoulder will be excavated for roadway widening. The project plans and water pollution control drawings (WPCDs) in the SWPPP show the areas that will be excavated. No other areas are expected to accumulate significant precipitation on the project when it rains. If other areas are observed to accumulate precipitation, they will be added by amending this APP.

### BMPs Selected to Protect Accumulated Precipitation

To keep accumulated rainwater in the excavated areas from becoming laden with sediment, the excavated areas will be protected with erosion and sediment control BMPs as described in Section 500.4.1 and 500.4.2 of the SWPPP. A sand bag barrier will be placed along the edge of the shoulder where the shoulder meets the existing vegetation that will be preserved during construction. The excavated areas will be provided with compacted base in accordance with the contract plans and specifications as much as possible 24 hours before a 50% or more chance of rain. Plastic sheeting will be kept on hand to further protect areas where compacted base cannot be placed prior to a rain event. At no time will more than an acre of exposed soil be allowed when there is a 50% chance of rain. If it begins raining, the remaining exposed soil will be covered with plastic to prevent erosion. The potential flows along the length of the roadway will be checked using check dams. The combination of compacted base, plastic sheeting, check dams and sandbag barriers should provide an effective erosion and sediment control prior to rainwater entering the storm drain system. Drain inlets will also be protected during construction using the storm drain inlet BMPs described in Section 500.4.2 of the SWPPP. In addition, during the roadway paving and removal of existing materials, drain inlets will be covered when rain is not expected using filter fabric and sand bags as described in Section 500.4.6 of the SWPPP, BMP NS-3 and as shown in WPCD 14 of the SWPPP (drain inlet cover detail). Note: SC-10 drain inlet protection is not adequate for non-storm water discharges such as paving.

### Option(s) for not Discharging Accumulated Precipitation

# EXAMPLE

If less than 3,000 gallons of water is accumulated (standard size of water truck tank), the water may be pumped into the water truck on site and used for dust control in accordance with BMP WE-1 as described in Section 500.4.4 of the SWPPP. The accumulated precipitation may be pumped to a tank if it is determined to be feasible by the contractor. The stored water will be used for dust control or will be disposed of properly offsite.

## **Inspection Prior to Discharge**

After a precipitation event, water that is trapped in the excavation may need to be discharged to continue construction. The water will be inspected to determine whether it has come into contact with any other pollutants (e.g., spilled fuel) prior to discharge. If other pollutants are suspected, the water will be handled in accordance with BMP WM-10 liquid waste management for disposal off site.

## **Discharge BMPs and Location(s)**

If sediment is the only potential pollutant, the water will be discharged through a gravity bag filter (See attached typical construction drawing and specifications). The accumulated rainwater will be pumped through a non-woven geotextile fabric that collects sand, silt and fines as described in BMP NS-2. The pump will be selected to match the flow capacity of the gravity bag filter in accordance with the manufacturer's specifications. The sediment particle size, the available pore sizes of the filter material and the expected flow rates will be considered when selecting the proper pump and filter bag. The bag may need to be cleaned frequently if there is clogging. The bag material (pore size) or pump may need to be changed to address clogs, bursts or other problems. The manufacturer's specifications are attached to this APP. The actual size of the gravity bag filter, and pump will be determined after the rain event and will coincide with the amount of water trapped.

The gravity bag filter will be located on a paved area as shown on WPCD 4 of the SWPPP, where the additional water will not result in erosion. The flow path from the gravity bag filter to the storm drain inlet will be inspected and cleaned as necessary to prevent transfer of pollutants to the storm drain system. The gravity bag filter will be placed on a bed of clean gravel 0.4 to 0.8 inch in diameter that will extend outside the bag at least 6 inches on all sides.

## **Notification**

The Engineer will be informed prior to each discharge of accumulated precipitation even though this procedure is followed.

## **Sampling and Analysis**

The discharge of accumulated precipitation will be sampled and analyzed in accordance with the sampling and analysis plan in the SWPPP Section 600.2.

**Inspection, Maintenance and Repair**

The gravity bag filter will be monitored hourly during discharge events. The flow, bag condition, bag capacity and secondary gravel barrier will be inspected for adequate function. If the discharge treatment system is not functioning adequately, the discharge will be stopped immediately. The gravity bag filter will be maintained and repaired as necessary for adequate function. If necessary the treatment method will be modified and a revised APP will be submitted to the Engineer for Approval prior to discharge.

*Joe Control*

September 26, 2007

---

Contractor's QSP or BMP Manager  
Signature

Date

Joe Control/ QSP

(800) 123-4567

---

Contractor's QSP or BMP Manager  
Name and Title

Telephone Number

# EXAMPLE



## Typical Construction:

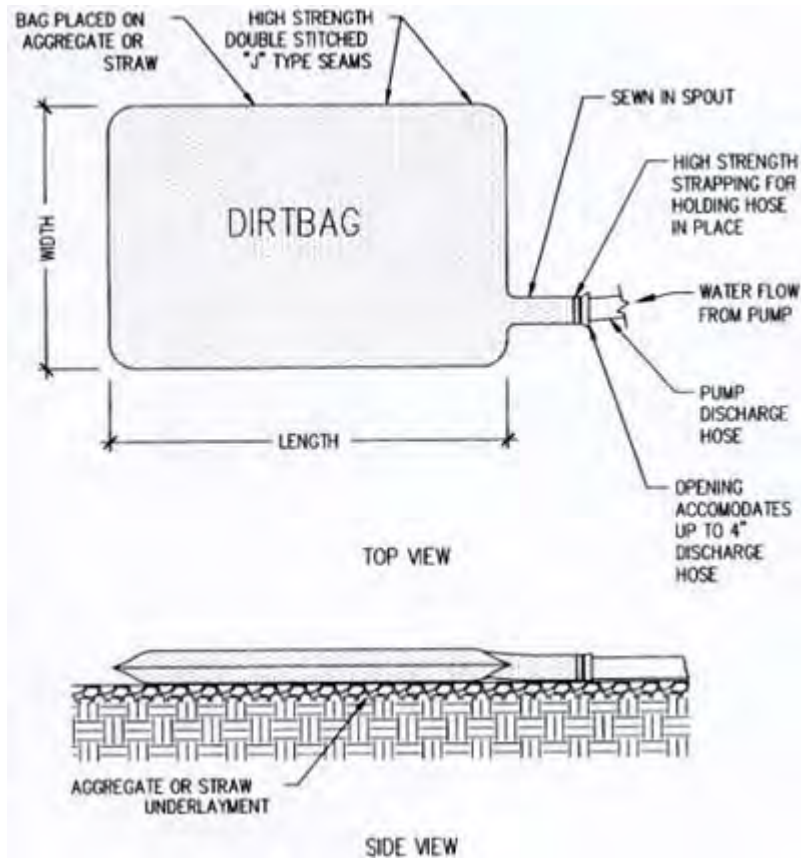

## Dirtbag® Specification:

Control of Sediment In Pumped Water

### 1.0 Description

1.1 This work shall consist of furnishing, placing and removing Dirtbag® pumped sediment control device as directed by the design engineer or as shown on the contract drawings. Dirtbag® pumped-silt control system is marketed by The BMP Store.

### 2.0 Materials

#### 2.1 Dirtbag®

2.1.1 Dirtbag® shall be manufactured using a polypropylene nonwoven geotextile from SI Geosolutions, then sewn into a bag with a double needle matching using a high strength thread.

2.1.2 Each standard Dirtbag® has a fill spout large enough to accommodate a 4" discharge hose. Straps are attached to secure the hose and prevent pumped water from escaping without being filtered.

2.1.3 Dirtbag® seams shall have an average wide width strength per ASTM D-4884 as follows:



# EXAMPLE

Dirtbag® Style	Test Method	Test Method		
Dirtbag® 53	ASTM D-4884	60 lbs./in		
Dirtbag® 55	ASTM D-4884	100 lbs./in		
Property	Test Method	Units	Test Results	
			Style 53	Style 55
Weight	ASTM D-3776	oz/yd	8	10
Grab Tensile	ASTM D-4632	lbs.	205	250
Puncture	ASTM D-4833	lbs.	110	150
Flow Rate	ASTM D-4491	gal/min/ft <sup>2</sup>	110	85
Permittivity	ASTM D-4491	sec. <sup>-1</sup>	1.5	1.2
Mullen Burst	ASTM D-3786	lbs. ft <sup>2</sup>	350	460
UV Resistant	ASTM D-4355	%	70	70
AOS % Retained	ASTM D-4751	US Sieve	80	100

All properties are Minimum Average Roll Value (MARV) except the weight of the fabric which is given for information only. Depending on soil conditions and filtration requirements, additional geotextile options are available. Please call our engineering staff for solutions.

### 3.0 Construction Sequence

3.1.1 To install Dirtbag® on a slope so incoming water flows downhill through Dirtbag® without creating more erosion. Strap the neck of Dirtbag® tightly to the discharge hose. To increase the efficiency of filtration, place the bag on an aggregate or haybale bed to maximize water flow through the surface area of the bag.

3.1.2 Dirtbag® is full when it no longer can efficiently filter sediment or allow water to pass at a reasonable rate. Flow rates will vary depending on the size of Dirtbag®, the type and amount of sediment discharged into Dirtbag®, the type of ground, rock or other substance under the bag and the degree of the slope on which the bag lies. Under most circumstances Dirtbag® will accommodate flow rates of 1100 gallons per minute. Use of excessive flow rates or overfilling Dirtbag® with sediment will cause the bag to rupture or failure of the hose attachment straps.

3.1.3 Dispose Dirtbag® as directed by the site engineer. If allowed, Dirtbag® may be cut open and the contents seeded after removing visible fabric. Dirtbag® is strong enough to be lifted with optional straps if it must be hauled away. Off-site disposal may be facilitated by placing Dirtbag® in the back of a dump truck or flatbed prior to use and allowing the water to drain from the bag while in place, thereby eliminating the need to lift Dirtbag®.

### 4.0 Basis of Payment

4.1 The payment for any Dirtbag® used during construction is to be included in the bid of overall erosion and sediment control plan unless a unit price is requested.

**REQUIRED TEXT: To be completed by Contractor for all projects if APP is required.**

## Accumulated Precipitation Procedure (APP)

Project Name: \_\_\_\_\_

Project ID/ID Number: \_\_\_\_\_

**[Check appropriate box below based on contract Special Provisions Section 7-8.6.]**

SWPPP required for this project

SWPPP not required for this project

This project may accumulate precipitation due to: **[Insert brief description of how precipitation may be trapped on site such as in low lying areas, planned excavations or other means where it may be necessary to discharge water to the storm drain system or water body.]** No accumulated water will be discharged without implementing this accumulated precipitation procedure (APP).

### **Areas Expected to Trap Precipitation**

**[Describe in detail the areas that are expected to trap rain water on the construction site.]**

### **BMPs Selected to Protect Accumulated Precipitation**

**[Describe BMPs that are selected for the project that will minimize sediment in accumulated precipitation, if any.]**

### **Option(s) for not Discharging Accumulated Precipitation**

**[Describe options for not discharging accumulated precipitation offsite such as storing the water on site, infiltration, using the water for dust control or other method approved by the Engineer.]**

### **Inspection Prior to Discharge**

After a precipitation event, water that is trapped in the excavation may need to be discharged to continue construction. The water will be inspected to determine whether it has come into contact with any other pollutants (e.g., spilled fuel) prior to discharge. If other pollutants are suspected, the water will be handled in accordance with BMP WM-10 liquid waste management for disposal off site.

### **Discharge BMPs and Location(s)**

If sediment is the only potential pollutant, the water will be **[Describe how NS-2 Dewatering Operations BMPs will be implemented including a description of the selected BMPs and equipment for minimizing sediment in the discharge. Describe the location of the BMPs and equipment to be used.]**  
**[Describe location(s) of the discharge such as to the gutter, drain inlet,**

**water body, etc. Include BMPs for erosion control and velocity dissipation at the discharge point where erosion could occur.]**

**Notification**

The Engineer will be informed prior to each discharge of accumulated precipitation even though this procedure is followed.

**Sampling and Analysis**

The discharge of accumulated precipitation will be sampled and analyzed in accordance with the sampling and analysis plan in the SWPPP Section 600.2. **[If the construction project does not require a SWPPP, delete this sampling and analysis section.]**

**Inspection, Maintenance and Repair**

The accumulated precipitation discharge and associated BMPs and equipment will be monitored hourly during discharge events. The flow, BMP conditions and potential for sediment in the flow path will be inspected. In the event the BMPs, equipment or flow path are not functioning adequately, the discharge will be stopped until the treatment system is maintained or repaired to function adequately. This may require a revision to this APP which will need to be approved by the Engineer.

\_\_\_\_\_  
Contractor's QSP or BMP Manager                      Date  
Signature

\_\_\_\_\_  
Contractor's QSP or BMP Manager                      Telephone Number  
Name and Title

(This page left intentionally blank)

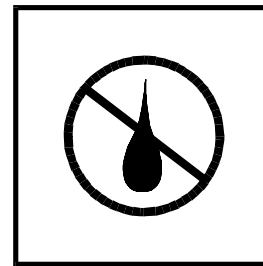
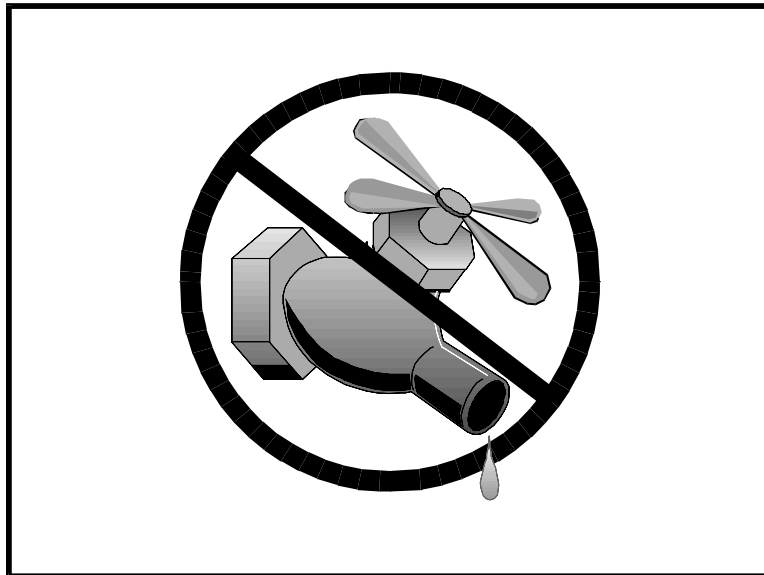

Standard Symbol

### BMP Objectives

- Soil Stabilization
- Sediment Control
- Tracking Control
- Wind Erosion Control
- Non-Storm Water Management
- Materials and Waste Management

**Definition and Purpose** Water conservation practices are activities that use water during the construction of a project in a manner that avoids discharge to the ground or discharge causing erosion and/or the transport of pollutants off site.

**Appropriate Applications**

- Water conservation practices are implemented on all construction sites and wherever water is used.
- Applies to all construction projects.

**Limitations** ■ None identified.

**Standards and Specifications**

- Keep water equipment in good working condition.
- Stabilize water truck filling area.
- Repair water leaks immediately.
- Do not allow water to flow offsite or into storm drain system.
- Vehicles and equipment washing on the construction site is discouraged.
- Avoid using water to clean construction areas. Do not use water to clean pavement. Paved areas shall be swept and vacuumed.
- Direct construction water runoff to areas where it can infiltrate into the ground.
- Apply water for wind erosion control in accordance with WE-1 BMPs.
- Report discharges to Engineer immediately.

- Maintenance and Inspection**
- Inspect water conservation practices weekly and before and after every rainfall events. During extended rainfall events, inspect water conservation practices at least once every 24 hours.
  
  - Repair water equipment as needed or as directed by the Engineer.



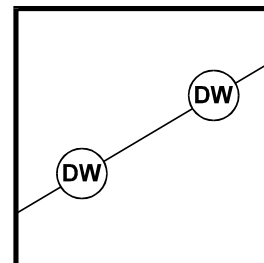

Standard Symbol

### BMP Objectives

- Soil Stabilization
- Sediment Control
- Tracking Control
- Wind Erosion Control
- Non-Storm Water Management
- Materials and Waste Management

**Definition and Purpose** Dewatering Operations are practices that manage the discharge of pollutants when non-storm water and accumulated precipitation (storm water) must be removed from a work location so that construction work may be accomplished.

- Appropriate Applications**
- These practices are implemented for discharges of non-storm water and storm water (accumulated rain water) from construction sites. Non-storm water includes, but is not limited to, dewatering of piles, water from cofferdams, water diversions, and water used during construction activities that must be removed from a work area.
  - Practices identified in this section are also appropriate for implementation when managing the removal of accumulated precipitation (storm water) from a construction site.
  - Storm water mixed with non-storm water shall be managed as non-storm water.

- Limitations**
- All construction groundwater dewatering shall be in full compliance with the contract special provisions and Monitoring and Reporting Program and Waste Discharge Requirements (WDR) of the NPDES permit included in the contract Special Provisions. All Contractor operations shall be in full compliance with all applicable laws and regulations that govern water quality.
  - If groundwater is encountered on the construction site and the contract Special Provisions do **not** include provisions for construction dewatering, the Contractor shall immediately notify the Engineer for direction. No groundwater shall be discharged to the sanitary sewer system, street/gutter, or any other location, whether contaminated, treated, or not, without prior approval by the Engineer.

## Standards and Specifications

- Dewatering for accumulated precipitation (storm water) shall follow this BMP in accordance with the approved Accumulated Precipitation Procedure (APP) and use treatment measures specified herein (See example in Section 7.2).
- The Contractor shall submit an APP as part of the SWPPP detailing methods and procedures for management and discharge of accumulated precipitation on the construction site, including treatment technologies/BMPs, equipment, discharge locations, and all other pertinent information. If a SWPPP is not required per the contract Special Provisions, the Contractor shall prepare an APP and submit it to the Engineer separately.
- Sediment control and other appropriate BMPs. Implement SS-10 “Outlet Protection/Velocity Dissipation Devices” to prevent erosion at the discharge point.
- Discharges must comply with regional and watershed-specific discharge requirements.
- The controls discussed in this BMP address sediment only. If the presence of other pollutants is identified in the contract Special Provisions, the Contractor shall implement dewatering pollution controls as required by the contract Special Provisions.
- If other pollutants are identified or suspected in the water to be removed by dewatering, and are not identified in the contract Special Provisions, the contractor shall not discharge the water and immediately notify the Engineer.
- Reuse water on-site (such as dust control, compaction, etc) if approved by the Engineer.
- Treatment system shall be fenced to prevent unauthorized entry
- Additional permits or permissions from other agencies may be required for dewatering cofferdams or diversions.

## Maintenance and Inspection

- Inspect dewatering operations daily and document weekly and before and after every rainfall events. During extended rainfall events, inspect paving and grinding operations at least once every 24 hours.
- Inspect all BMPs implemented to comply with permit requirements frequently and repair or replace BMPs to ensure they function as designed.
- Conduct water quality monitoring pursuant to the permit requirements of the contract Special Provisions. Documentation must be included in the SWPPP.
- Accumulated sediment that is commingled with other pollutants must be disposed of in accordance with all applicable laws and regulations and as approved by the Engineer.



## Sediment Treatment

A variety of methods can be used to treat water during dewatering operations from the construction site. Several devices are presented in this section that provide options to achieve sediment removal. The size of particles present in the sediment and Permit or receiving water limitations on sediment are key considerations for selecting sediment treatment option(s); in some cases, the use of multiple devices may be appropriate. If a selected method or device does not adequately remove sediment, a different or additional method shall be implemented.

### Category 1: Constructed Settling Technologies

The devices discussed in this category are to be used exclusively for dewatering operations only.

#### Sediment/Desilting Basin (SC-2)

A sediment/desilting basin is a temporary basin with a controlled release structure that is formed by excavation and/or construction of an embankment to detain sediment-laden runoff and allow sediment to settle out before discharging.

Appropriate Applications:

- Effective for the removal of trash, gravel, sand, and silt and some metals that settle out with the sediment.

Maintenance:

- Maintenance is required for safety fencing, vegetation, embankment, inlet and outfall structures, as well as other features.
- Removal of sediment is required when the storage volume is reduced by one-third.

#### Sediment Trap (SC-3)

A sediment trap is a temporary basin formed by excavation and/or construction of an earthen embankment across a waterway or low drainage area to detain sediment-laden runoff and allow sediment to settle out before discharging.

Appropriate Applications:

- Effective for the removal of large and medium sized particles (sand and gravel) and some metals that settle out with the sediment.

Maintenance:

- Maintenance is required for vegetation, embankment, inlet and outfall structures, as well as other features.
- Removal of sediment is required when the storage volume is reduced by one-third.

## Category 2: Mobile Settling Technologies

The devices discussed in this category are typical of tanks that can be used for sediment treatment of dewatering operations. A variety of vendors are available who supply these tanks.

### Weir Tank

A weir tank separates water and waste by using weirs. The configuration of the weirs (over and under weirs) maximizes the residence time in the tank and determines the waste to be removed from the water, such as oil, grease, and sediments.

#### Appropriate Applications:

- The tank removes trash, some settleable solids (gravel, sand, and silt), some visible oil and grease, and some metals (removed with sediment). To achieve high levels of flow, multiple tanks can be used in parallel. If additional treatment is desired, the tanks can be placed in series or as pre-treatment for other methods.

#### Implementation:

- Tanks are delivered to the site by the vendor, who can provide assistance with set-up and operation.
- Tank size will depend on flow volume, constituents of concern, and residency period required. Vendors shall be consulted to appropriately size tank.

#### Maintenance:

- Periodic cleaning is required based on visual inspection or reduced flow.
- Oil and grease disposal must be by licensed waste disposal company in accordance with WM-6.

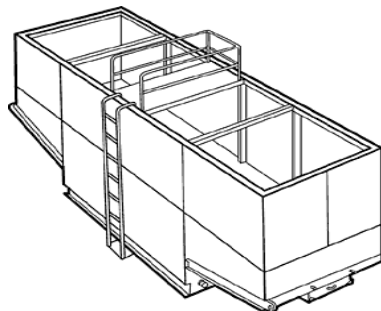

**Weir Tank**

## Dewatering Tank

A dewatering tank removes debris and sediment. Flow enters the tank through the top, passes through a fabric filter, and is discharged through the bottom of the tank. The filter separates the solids from the liquids.

### Appropriate Applications:

- The tank removes trash, gravel, sand, and silt, some visible oil and grease, and some metals (removed with sediment). To achieve high levels of flow, multiple tanks can be used in parallel. If additional treatment is desired, the tanks can be placed in series or as pre-treatment for other methods.

### Implementation:

- Tanks are delivered to the site by the vendor, who can provide assistance with set-up and operation.
- Tank size will depend on flow volume, constituents of concern, and residency period required. Vendors shall be consulted to appropriately size tank.

### Maintenance:

- Periodic cleaning is required based on visual inspection or reduced flow.
- Oil and grease disposal must be by licensed waste disposal company in accordance with WM-6..



Dewatering Tanks

## Category 3: Basic Filtration Technologies

### Gravity Bag Filter

A gravity bag filter, also referred to as a dewatering bag, is a square or rectangular bag made of non-woven geotextile fabric that collects sand, silt, and fines.

#### Appropriate Applications:

- Effective for the removal of sediments (gravel, sand, and silt). Some metals are removed with the sediment.

#### Implementation:

- Water is pumped into one side of the bag and seeps through the bottom and sides of the bag.
- A secondary barrier, such as a rock filter bed or gravel bag barrier, is placed beneath and beyond the edges of the bag to capture sediments that escape the bag.

#### Maintenance:

- Inspection of the flow conditions, bag condition, bag capacity, and the secondary barrier is required.
- Replace the bag when it no longer filters sediment or passes water at a reasonable rate.
- The bag is disposed off-site, or on-site as directed by the Engineer.

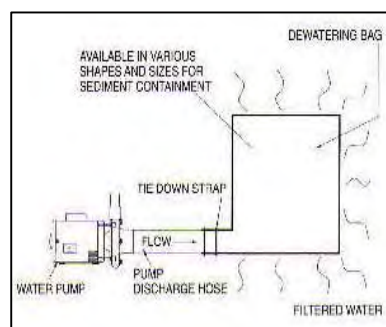

**Gravity Bag Filter**

## Category 4: Advanced Filtration Technologies

### Sand Media Particulate Filter

Water is treated by passing it through canisters filled with sand media. Generally, sand filters provide a final level of treatment. They are often used as a secondary or higher level of treatment after a significant amount of sediment and other pollutants have been removed.

Appropriate Applications:

- Effective for the removal of trash, gravel, sand, and silt and some metals, as well as the reduction of biochemical oxygen demand (BOD) and turbidity.
- Sand filters can be used for standalone treatment or in conjunction with bag and cartridge filtration if further treatment is required.
- Sand filters can also be used to provide additional treatment to water treated via settling or basic filtration.

Implementation:

- The filters require delivery to the site and initial set up. The vendor can provide assistance with installation and operation.

Maintenance:

- The filters require monthly service to monitor and maintain the sand media.



**Sand Media Particulate Filters**

## Pressurized Bag Filter

A pressurized bag filter is a unit composed of single filter bags made from polyester felt material. The water filters through the unit and is discharged through a header, allowing for the discharge of flow in series to an additional treatment unit. Vendors provide pressurized bag filters in a variety of configurations. Some units include a combination of bag filters and cartridge filters for enhanced contaminant removal.

### Appropriate Applications:

- Effective for the removal of sediment (sand and silt) and some metals, as well as the reduction of BOD, turbidity, and hydrocarbons. Oil absorbent bags are available for hydrocarbon removal.
- Filters can be used to provide secondary treatment to water treated via settling or basic filtration.

### Implementation:

- The filters require delivery to the site and initial set up. The vendor can provide assistance with installation and operation.

### Maintenance:

- The filter bags require replacement when the pressure differential exceeds the manufacturer's recommendation.



**Pressurized Bag Filter**

## Cartridge Filter

Cartridge filters provide a high degree of pollutant removal by utilizing a number of individual cartridges as part of a larger filtering unit. They are often used as a secondary or higher (polishing) level of treatment after a significant amount of sediment and other pollutants are removed. Units come with various cartridge configurations (for use in series with pressurized bag filters) or with a larger single cartridge filtration unit (with multiple filters within).

### Appropriate Applications:

- Effective for the removal of sediment (sand, silt, and some clays) and metals, as well as the reduction of BOD, turbidity, and hydrocarbons. Hydrocarbons can effectively be removed with special resin cartridges.
- Filters can be used to provide secondary treatment to water treated via settling or basic filtration.

### Implementation:

- The filters require delivery to the site and initial set up. The vendor can provide assistance.

### Maintenance:

- The cartridges require replacement when the pressure differential exceeds the manufacturer's recommendation.



**Cartridge Filter**

(This page left intentionally blank)



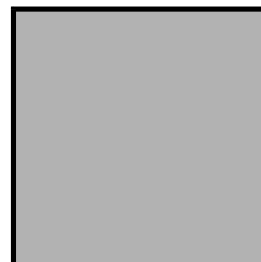
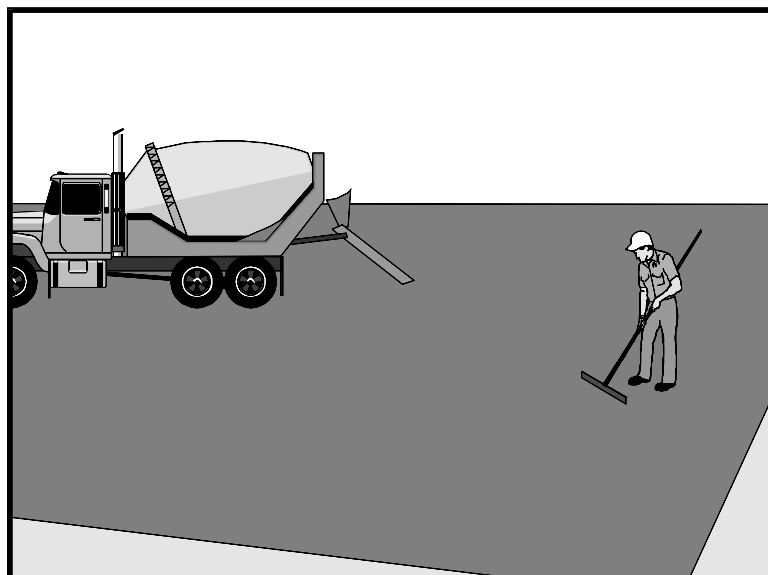

Standard Symbol

### BMP Objectives

- Soil Stabilization
- Sediment Control
- Tracking Control
- Wind Erosion Control
- Non-Storm Water Management
- Materials and Waste Management

**Definition and Purpose** Procedures and practices for conducting paving, concrete slurry, cement or masonry, saw cutting, and grinding operations to minimize the transport of pollutants to the storm drain system or receiving water body.

**Appropriate Applications** These procedures are implemented where paving, surfacing, resurfacing, grinding, slurry, cement, mortar or sawcutting, may pollute storm water runoff or discharge to the storm drain system or watercourses.

**Limitations**

- Finer solids are not effectively removed by sediment control BMPs (SC-1 through SC-10) settling or filtration systems. SC-10 is not adequate for drain inlet protection from paving/concrete pollutants.

**Standards and Specifications**

- Substances used to coat asphalt transport trucks, asphalt trucks, and asphalt spreading equipment shall not contain soap and shall be non-foaming and non-toxic.
- Place plastic materials under asphaltic concrete (AC) paving equipment while not in use, to catch and/or contain drips and leaks. See also BMP WM-4, “Spill Prevention and Control.”
- When paving involves AC, the following steps shall be implemented to prevent the discharge of uncompacted or loose AC, tack coats, equipment cleaners, or other paving materials:
  - Minimize sand and gravel from new asphalt from getting into storm drains, streets, and creeks by sweeping.
  - Old, broken, or spilled asphalt shall be removed from the project site and recycled or disposed of as approved by the Engineer.
  - AC grindings, pieces, or chunks shall not be used in embankments or shoulder backing unless approved by the Engineer.

- Collect and remove all broken asphalt and recycle off-site or dispose of offsite in accordance with all applicable laws and regulations.
- During chip seal application and sweeping operations, petroleum or petroleum covered aggregate shall not be discharged to the ground surface, enter any storm drain or water courses. Filter fabrics or plastic must be used to cover inlets to prevent any discharge of sediment or water until installation is complete.
- Use only non-toxic substances to coat asphalt transport trucks and asphalt spreading equipment.
- Drainage inlet structures and manholes shall be covered with plastic during application of seal coat, tack coat, slurry seal, and/or fog seal, or any other paving/concrete, cement, slurry or mortar related pollutant to prevent any discharge to the storm drain system.
- Seal coat, tack coat, slurry seal, or fog seal shall not be applied if rainfall is predicted to occur during the application or curing period.
- Paving equipment parked onsite shall be parked over plastic to prevent discharge to the ground surface.
- No washing of asphalt equipment shall be conducted on-site. When cleaning dry, hardened asphalt from equipment, manage hardened asphalt debris as described in BMP WM-5, “Solid Waste Management.” Any cleaning onsite shall follow BMP NS-8, “Vehicle and Equipment Cleaning.”
- Do not wash sweepings from exposed aggregate concrete into a storm drain system. Collect and return to stockpile (WM-3), or dispose of properly.

### **Sawcutting**

- Do not conduct sawcutting during rain or when there is a 50% percent chance of measurable precipitation (0.01 inches or more).
- Use minimum sawcutting blade speed to reduce required amount of water needed.
- Vacuum up sawcutting waste as it is generated. Do not wait to complete sawcutting operation.
- After vacuuming, the fine slurry shall be swept up after it dries.
- Do not allow sawcutting waste slurry to get to storm drain inlet. SC-10 Storm Drain Inlet Protection and other sediment BMPs are not adequate to prevent discharge. Drain inlets shall be protected by impervious materials such as plastic. The impervious drain inlet protection shall be removed after the sawcutting operation is completed and all waste is cleaned up. The waste slurry must be completely contained in a concrete washout (WM-8) and/or shall be disposed of offsite without discharging

to permeable or impermeable surfaces.

## ***Pavement Grinding or Removal***

- Residue from PCC grinding operations shall be picked up by means of a vacuum attachment to the grinding machine, shall not be allowed to flow across the pavement, and shall not be left on the surface of the pavement. See also BMP WM-8, “Concrete Waste Management;” and BMP WM-10, “Liquid Waste Management.”
- Collect pavement digout material by mechanical or manual methods. This material may be recycled if approved by the Engineer for use as shoulder backing or base material at locations approved by the Engineer.
- If digout material cannot be recycled, transport the material to a storage site approved by the Engineer or offsite in accordance with all applicable laws and regulations. Digout activities shall not be conducted in the rain.
- When approved by the Engineer, stockpile material removed from roadways away from drain inlets, drainage ditches, and watercourses and stored consistent with BMP WM-3, “Stockpile Management.”
- Disposal or use of AC grindings shall be approved by the Engineer. See also BMP WM-8, “Concrete Waste Management.”
- No “kick-brooms” shall be used.

## ***Thermoplastic Striping***

- All thermoplastic striper and pre-heater equipment shutoff valves shall be inspected to ensure that they are working properly to prevent leaking thermoplastic from entering drain inlets, the storm water drainage system, or watercourses.
- The pre-heater shall be filled carefully to prevent splashing or spilling of hot thermoplastic. Leave six inches of space at the top of the pre-heater container when filling thermoplastic to allow room for material to move when the vehicle is deadheaded.
- Contractor shall not pre-heat, transfer, or load thermoplastic near drain inlets or watercourses.
- Clean truck beds daily of loose debris and melted thermoplastic. When possible recycle thermoplastic material. Thermoplastic waste shall be disposed of in accordance with all applicable laws and regulations.

## ***Raised/Recessed Pavement Marker Application and Removal***

- Do not transfer or load bituminous material near drain inlets, the storm water drainage system or watercourses.



## Maintenance and Inspection

- Melting tanks shall be loaded with care and not filled to beyond six inches from the top to leave room for splashing when vehicle is deadheaded.
- When servicing or filling melting tanks, ensure all pressure is released before removing lids to avoid spills.
- On large scale construction sites, use mechanical or manual methods to collect excess bituminous material from the roadway after removal of markers.
- Waste shall be disposed of in accordance with all applicable laws and regulations.
- Inspect paving and grinding operations weekly and before and after every rainfall events. During extended rainfall events, inspect paving and grinding operations at least once every 24 hours.
- Inspect sawcutting operation and ensure that all waste slurry is vacuumed up. Any residual shall be swept or scraped up if necessary to remove it.
- Ensure that employees and subcontractors are implementing appropriate measures during paving operations.

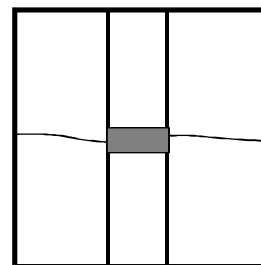
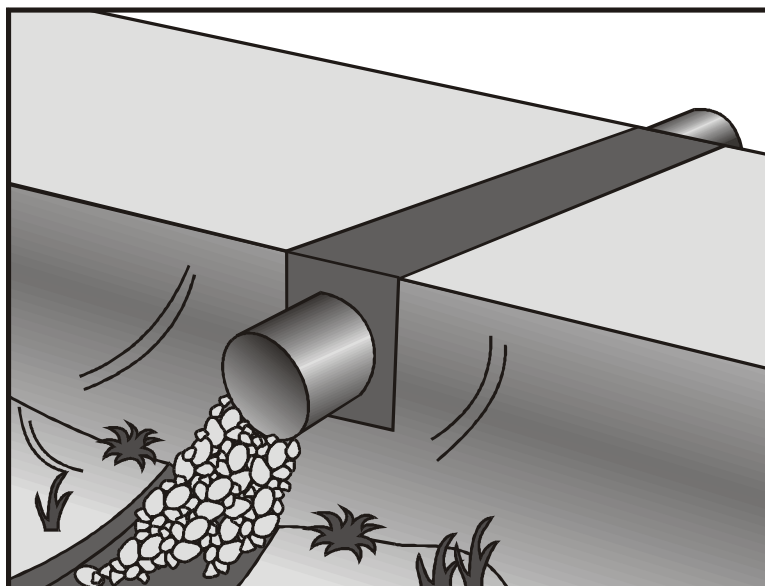

Standard Symbol

### BMP Objectives

- Soil Stabilization
- Sediment Control
- Tracking Control
- Wind Erosion Control
- Non-Storm Water Management
- Materials and Waste Management

**Definition and Purpose** A temporary stream crossing is a structure placed across a waterways, drainage swales or ditches that allows vehicles to cross the waterway during construction, minimizing, reducing, or managing erosion and downstream sedimentation caused by the vehicles.

**Appropriate Applications** Temporary stream crossings are installed at sites:

- Where construction equipment or vehicles need to cross a waterways drainage swales or ditches.

**Limitations**

- Fully comply with the specific permit requirements or mitigation measures identified in the contract Special Provisions and all regulatory permits, such as Regional Water Quality Control Board (RWQCB) 401 Certification, U.S. Army Corps of Engineers 404 permit, California Department of Fish and Game Streambed Alteration Agreement, and US Forest Service Permits. Comply with all water quality monitoring and numerical-based water quality standards identified in the contract Special Provisions and all regulatory permits.

- Appropriate erosion and sediment control BMPs shall be installed during construction and removal of stream crossing.

- May become a constriction in the waterway, which can obstruct flood flow and cause flow backups or washouts. If improperly designed, flow backups can increase the pollutant load through washouts and scouring.

- Dry Ford shall only be used in the non-rainy season and when no flows are present. The use of the Ford is contingent on a 5-day clear weather forecast.

- CCS should not be used in excessively high or fast flows. Use of natural or other gravel in the stream for construction of Cellular Confinement System (CCS) crossing will be contingent upon approval by fisheries agencies.

- Upon completion of construction activities, all stream crossing shall be removed and the area stabilized and restored to pre-construction conditions or as directed by the Engineer.

## Standards and Specifications

### **General Considerations**

- No stream crossing is allowed without prior approval by the Engineer and compliance with the contract Special Provisions, applicable permits, laws and regulations.
- Select site where erosion potential is low.

The following types of temporary stream crossings shall be considered:

- Culverts - Used on perennial and intermittent streams.
- Dry Fords - Appropriate during the dry season only. Used on dry washes, streams, and channels.
- Cellular Confinement System (CCS) crossing structures consist of clean, washed gravel and cellular confinement system blocks. Used on dry washes and ephemeral streams, and low flow perennial streams.
- Bridges - Appropriate for streams with high flow velocities, steep gradients and/or where temporary restrictions in the channel are not allowed.

Design and installation requires knowledge of stream flows and soil strength. Stream crossing shall be designed by a professional Engineer registered with the State of California. The Design details shall be included in the SWPPP or SWPPP amendment or approved by the Engineer prior to construction. Both hydraulic and construction loading requirements shall be considered with the following:

- Comply with all applicable requirements for culvert and bridge crossings, particularly if the temporary stream crossing will remain through the rainy season.
- Provide stability in the crossing and adjacent areas to withstand the design flow. The design flow and safety factor shall be selected based on careful evaluation of the risks due to over flowing, flow backups, or washout.
- Shall not use oil or other potentially hazardous materials for surface treatment.
- A Spill Prevention and Clean-up Plan shall be developed and included in the SWPPP, or submitted to the Engineer for approval prior to construction, for all potential spills from the crossing as a result of construction traffic or activities.

## ***Construction Requirements:***

- Stabilize construction roadways, adjacent work area and streambed against erosion.
- Construct during the non-rainy season and 5-day clear weather forecast to minimize stream disturbance and reduce costs.
- Construct at or near the natural elevation of the stream bed to prevent potential flooding upstream of the crossing.
- Install temporary sediment control BMPs to minimize erosion of embankment into flow lines. Install Sediment Controls along the perimeter (sides) of the crossing.
- Vehicles and equipment shall not be driven, operated, fueled, cleaned, maintained, or stored in the streambed.
- Temporary water body crossings and encroachments shall be constructed to minimize scour. Cobbles used for temporary water body crossings or encroachments shall be clean, rounded river cobble.
- The exterior of vehicles and equipment that will encroach on the water body within the project shall be maintained free of grease, oil, fuel, and residues.
- Any temporary artificial obstruction placed within flowing water shall only be built from material, such as clean gravel, that will cause little or no siltation.
- Drip pans shall be placed under all vehicles and equipment placed on docks, barges, or other structures over water bodies when the vehicle or equipment is planned to be idle for more than one hour.
- Conceptual temporary stream crossings are shown in figures at the end of this section.

## ***Specific Requirements:***

- Culverts are relatively easy to construct and able to support heavy equipment loads.
- Dry Fords are the least expensive of the crossings, with maximum load limits.
- CCS allow designers to use either angular or naturally-occurring, rounded gravel, because the cells provide the necessary structure and stability. In fact, natural gravel is optimal for this technique, because of the habitat improvement it will provide after removal of the CCS.
- A gravel depth of 6 to 12 inches for a CCS structure is sufficient to support most construction equipment.
- An advantage of a CCS crossing structure is that relatively little rock or gravel is needed, because the CCS provides the stability.

## Maintenance and Inspection

- Bridges are generally more expensive to design and construct, but provides the least disturbance of the stream bed and constriction of the waterway flows.
- Inspect streambed crossing weekly and before and after every rainfall events. During extended rainfall events, inspect streambed crossing at least once every 24 hours.
- Removal of debris behind fords, in culverts, and under bridges as directed by the Engineer.
- Replacement of lost protective aggregate from inlets and outlets of culverts.
- Checking for blockage in the channel, debris buildup in culverts or behind fords, and under bridges.
- Checking for erosion of abutments, channel scour, riprap displacement, or piping in the soil.
- Checking for structural weakening of the temporary crossing, such as cracks, and undermining of foundations and abutments.
- Removal of temporary crossing promptly when it is no longer needed or as directed by the Engineer.





# Temporary Stream Crossing

NS-4

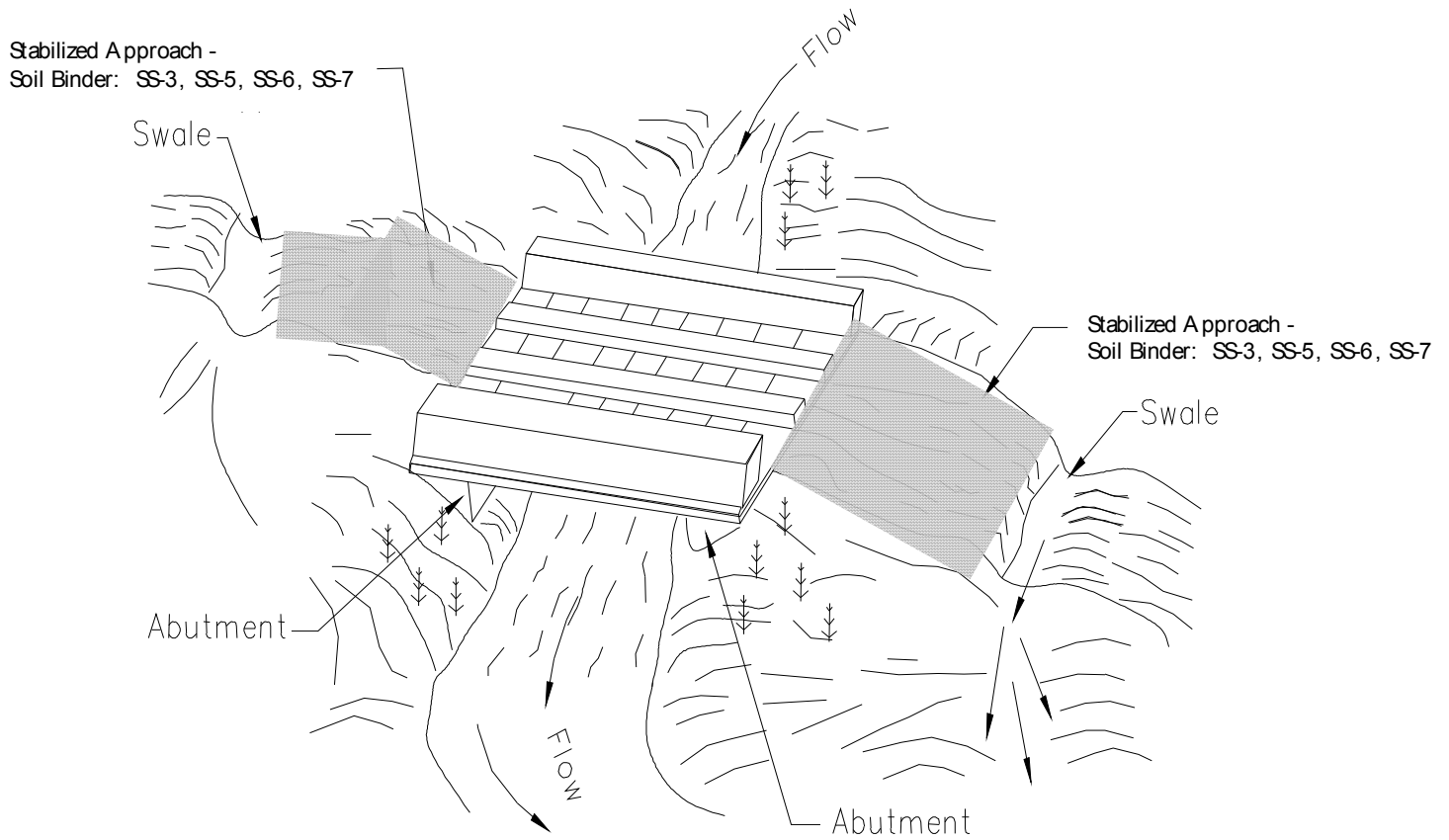

NOTE:  
Surface flow of road diverted  
by swale and/or dike.

TYPICAL BRIDGE CROSSING  
NOT TO SCALE



# Temporary Stream Crossing

**NS-4**

½ Diameter of pipe 12 inches, or as needed to support loads, whichever is greater

Coarse aggregate

Capacity of pipe culverts together = design flow + safety factor

Earth fill covered by large angular rock, upstream and downstream.

Engineering fabric

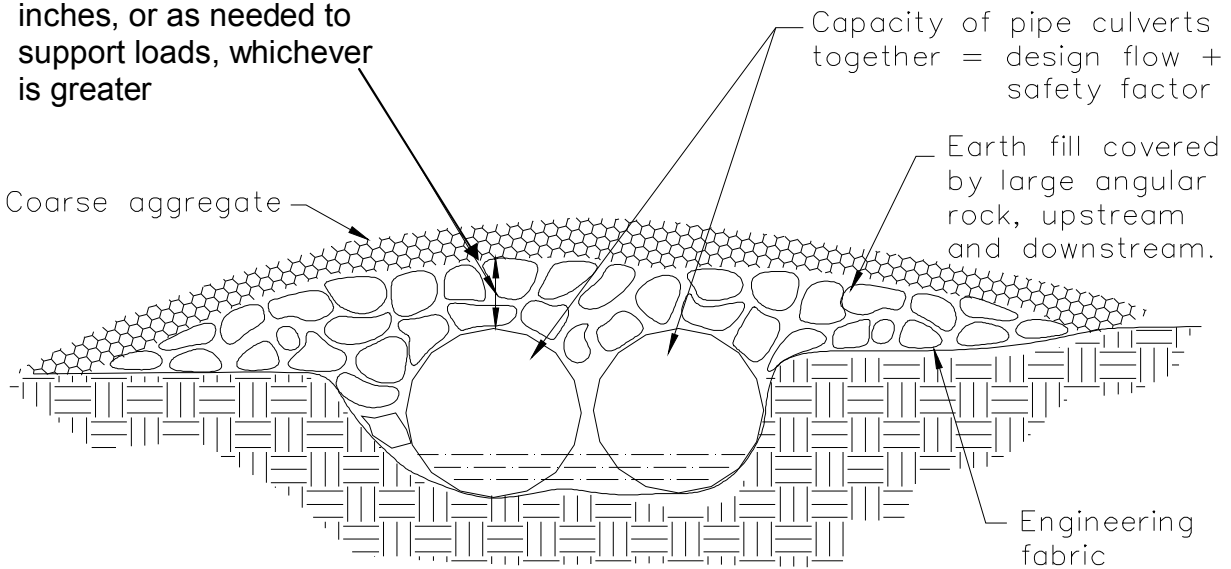

ELEVATION

Soil Binder: SS-3, SS-5, SS-6, SS-7

Approach stabilized with coarse aggregate

Approach stabilized with coarse aggregate

Large angular rock over earth fill, upstream & downstream.

Diversion and/or swale

Diversion and/or swale

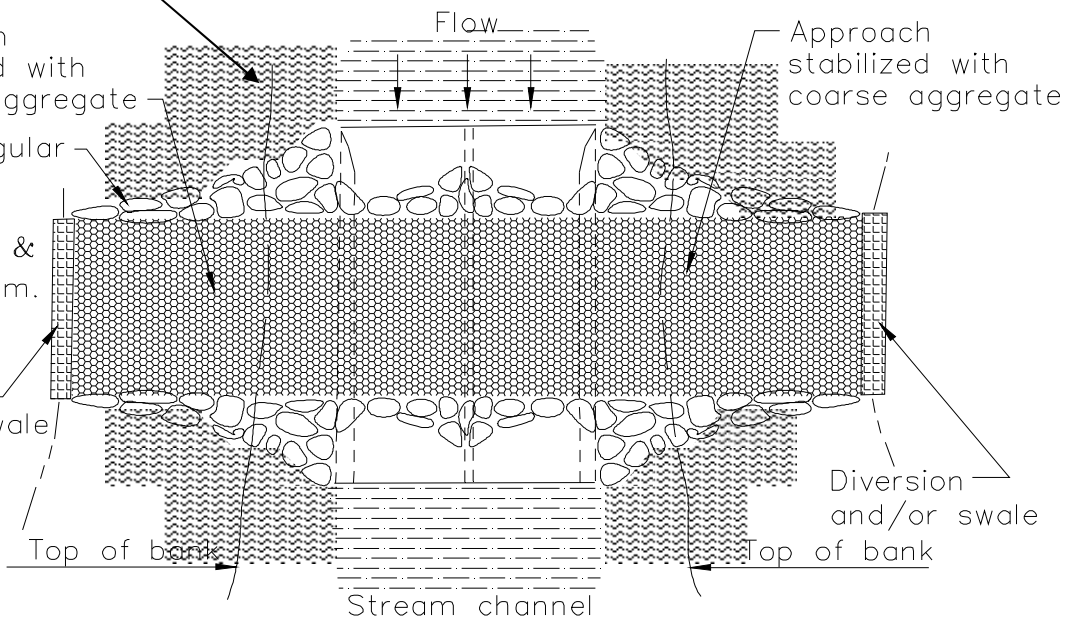

PLAN VIEW

TYPICAL CULVERT CROSSING  
NOT TO SCALE





CELLULAR CONFINEMENT SYSTEM

(This page left intentionally blank)

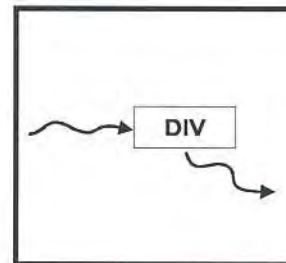
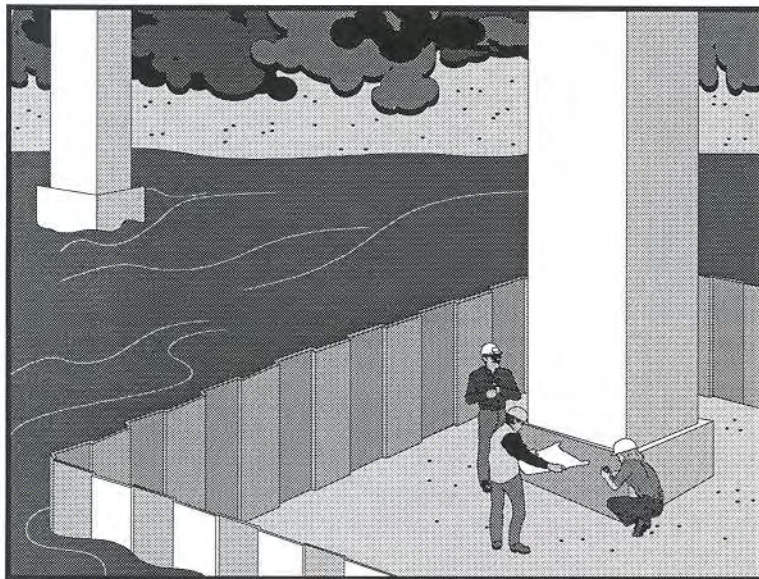

Standard Symbol

### BMP Objectives

- Soil Stabilization
- Sediment Control
- Tracking Control
- Wind Erosion Control
- Non-Storm Water Management
- Materials and Waste Management

**Definition and Purpose** Clear water diversion consists of a system of structures and measures that intercept clear surface water runoff upstream of a project site, transport it around the work area, and discharge it downstream with minimal water quality degradation for either the project construction operations or the construction of the diversion. Clear water diversions are used in a waterway or storm drain system to enclose a construction area and reduce sediment pollution from construction work occurring in or adjacent to water. Isolation techniques are methods that isolate near shore work from a waterbody. Structures commonly used as part of this system include diversion ditches, berms, dikes, slope drains, rock, gravel bags, wood, sheet piles, aqua barriers, cofferdams, filter fabric or turbidity curtains, drainage and interceptor swales, pipes, or flumes.

- Appropriate Applications**
- Clear water diversions are appropriate for isolating construction activities occurring within or near a water body such as streambank stabilization, or channel, culvert, bridge, piers or abutment repair or construction. They may also be used in combination with other methods, such as clear water bypasses and/or pumps.
  - Pumped diversions are suitable for intermittent and low flow streams. Excavation of a temporary bypass channel, or passing the flow through a pipe.
  - Fully comply with the specific permit requirements or mitigation measures identified in the contract Special Provisions and all regulatory permits, such as Regional Water Quality Control Board (RWQCB) 401 Certification, U.S. Army Corps of Engineers 404 permit, California Department of Fish and Game Streambed Alteration Agreement, and US Forest Service Permits. Comply with all water quality monitoring and numerical-based water quality standards identified in the contract Special Provisions and all regulatory permits.

- The Contractor is cautioned that the Project involves work within and requires removal of portions of streambed or an active flood control channel which is subject to flows of high and uncontrolled magnitude. Although such flows would most likely occur during the storm season, from October 15 to April 15, there is the possibility that such occurrences can take place at other times of the year. The Contractor shall assume all risks associated with working in an active streambed channel.
- The Contractor shall consult with the National Weather Service to determine the possibility of storms.
- The Contractor shall be responsible for providing for the passage of all flows through the Work site, maintaining water quality as required by the permits by implementation of BMPs, and the safety personnel, equipment, and materials under its jurisdiction.
- The Contractor shall provide for the flow of water from all sources, including nuisance water, through Work site at all times.

## Limitations

- Diversion/encroachment activities may constrict the waterway, which can obstruct flood flows and cause flooding or washouts. Diversion structures shall not be installed without identifying potential impacts to the stream channel.
- Between October 15<sup>th</sup> through April 15<sup>th</sup> the Contractor shall:
  - Maintain the capacity of the channel shall be maintained at 100% of design capacity.
  - Not conduct work, store materials/equipment, or operate equipment within the channel.
  - Completely remove all temporary surface water diversions structures from the channel.
- Diversion or isolation activities shall not completely dam stream flow.
- Dewatering and removal may require additional sediment control or water treatment (See NS-2, “Dewatering Operations”).

## Standards and Specifications

- The Contractor shall submit a Surface Water Diversion Plan per the contract Special Provisions for all working within a streambed or channel.
- If the contract Special Provisions do not contain requirements for a Surface Water Diversion Plan, then the Contractor shall prepare a Surface Water Diversion Plan, per this BMP, and submit it to the Engineer for approval prior to conducting any work over a watercourse.
- The Surface Water Diversion Plan shall be designed by a professional Engineer registered with the State of California. The Surface Water Diversion Plan shall be included in the SWPPP.

- The Contractor shall design, construct, maintain, and remove a temporary surface water diversion system as specified herein. The Surface Water Diversion Plan shall contain at a minimum the following information:
  - A written description of the Surface Water Diversion System.
  - A site plan (drawn to scale) and diagrammatic representation of the diversion of water system, showing the location of all BMPs, equipment within the project limits (including check dams, pumps, piping details, discharge and sampling locations, power source, etc.).
  - The Plan will also include equipment specifications and all other information, as requested by the Agency, for the complete understanding and operation of the dewatering plan.
- The contractor shall demonstrate to the satisfaction of the Engineer that all components of the temporary surface water diversion system are fully functional prior to initiation of any work in associated portion of the channel.
- The temporary surface water diversion system shall be water-tight. If any nuisance water leaks occur within the work area, the Contractor shall immediately contain and re-direct/remove the nuisance water away from the work areas.
- The Contractor shall strictly confine all work and storage of materials and equipment with the boundaries of the temporary surface water diversion system.
- During storms, obstructions such as equipment and materials shall be removed from the channel.
- All temporary improvements installed by the Contractor for the diversion of water, not specified as a permanent improvement as part of the contract, shall be removed and the site restored.
- The system shall be routinely cleaned of silt/sediment as directed by the Engineer and any required repaired made immediately. If during the progress of work, the Agency determines that the Plan or implementation of the Plan is inadequate, the Contractor shall, at his expense, furnish any equipment, labor, materials, and outside services necessary to perform the work satisfactory to the Agency.
- Excavation equipment buckets may reach out into the water for the purpose of removing or placing fill materials. Only the bucket of the crane/excavator/backhoe may operate in a water body. The main body of the crane/excavator/backhoe shall not enter the water body, except as necessary to cross the stream to access the work site.
- Implement guidelines presented in SS-12, Streambank Stabilization to minimize impacts to streambanks.

- All surrounding areas at the head wall and outfall structure shall be stabilized with SS-3, SS-4, SS-7, SS-12, or a combination of such if necessary.
- Stationary equipment such as motors and pumps, located within or adjacent to a water body, shall be positioned over drip pans.
- When any artificial obstruction is being constructed, maintained, or placed in operation, sufficient water shall, at all times, be allowed to pass downstream to maintain aquatic life downstream.
- The exterior of vehicles and equipment that will enter the streambed or channel shall be maintained free of grease, oil, fuel, and residues.
- Drip pans shall be placed under all vehicles and equipment, including vehicles or equipment will be idle for more than one hour.
- Where possible, avoid or minimize diversion/encroachment impacts by scheduling construction during periods of low flow or when the stream is dry. See also the contract Special Provisions for scheduling requirements. Scheduling shall also consider seasonal releases of water from dams, fish migration and spawning seasons, and water demands due to crop irrigation.
- Construct diversion structures with materials free of potential pollutants such as soil, silt, sand, clay, grease, or oil.

### ***Temporary Diversions/Encroachments***

- Construct diversion channels in accordance with BMP SS-9, “Earth Dikes/Drainage Swales, and Ditches.”
- In high flow velocity areas, stabilize slopes of embankments and diversion ditches using an appropriate liner, in accordance with BMP SS-7, “Geotextiles, Plastic Covers & Erosion Control Blankets/Mats”, or use rock slope protection.
- Where appropriate, use natural streambed materials such as large cobbles and boulders for temporary embankment/slope protection, or other temporary soil stabilization methods.
- Provide for velocity dissipation at transitions in the diversion, such as the point where the stream is diverted to the channel and the point where the diverted stream is returned to its natural channel. See also BMP SS-10, “Outlet Protection/Velocity Dissipation Devices.”

### ***Temporary Dry Construction Areas***

- When dewatering behind temporary structures to create a temporary dry construction area (such as coffer dams), pass pumped water through a sediment settling device, tank or settling basin, before returning water to the water body; see also BMP NS-2, “Dewatering Operations.”



- If pollutants (except sediment) are identified in the contract Special Provisions, the contractor shall fully comply with the contract Special Provisions. If pollutants (except sediment) are observed or identified, the contractor shall discharge any water and immediately notify the Engineer.
- Any substance used to assemble or maintain diversion structures, such as form oil, shall be non-toxic and non-hazardous.
- Any material used to minimize seepage underneath diversion structures, such as grout, shall be non-toxic, non-hazardous, and as close to a neutral pH as possible.

### ***Isolation Techniques:***

Isolation techniques are methods that isolate near shore work from a waterbody. Techniques include sheet pile enclosures, water-filled geotextile (Aqua Dam), gravel berm with impermeable membrane, gravel bags, coffer dams, and K-rail.

### ***Filter Fabric Isolation Technique***

A filter fabric isolation structure (See Figure 1D) is a temporary structure built into a waterway to enclose a construction area and reduce sediment pollution from construction work in or adjacent to water. This structure is composed of filter fabric, gravel bags, and steel t-posts.

### ***Appropriate Applications:***

- Filter fabric may be used for construction activities such as streambank stabilization, or culvert, bridge, pier or abutment installation. It may also be used in combination with other methods, such as clean water bypasses and/or pumps.
- This method involves placement of gravel bags or continuous berms to “key-in” the fabric, and subsequently staking the fabric in place.
- This is a method that should be used in relatively calm water, and can be used in smaller streams.

### ***Limitations***

- Do not use if the installation, maintenance and removal of the structures will disturb sensitive aquatic species of concern.
- Not appropriate for projects where dewatering is necessary.
- Not appropriate to completely dam streamflow.

### ***Standards and Specifications:***

- For the filter fabric isolation method, a non-woven or heavy-duty fabric is recommended over standard silt fence. Using rolled geotextiles allows non-standard widths to be used.

- Anchor filter fabric with gravel bags filled with clean, washed gravel. Do not use sand. If a bag should split open, the gravel can be left in the stream, where it can provide aquatic habitat benefits.
- Another anchor alternative is a continuous berm, made with the Continuous Berm Machine. This is a gravel-filled bag that can be made in very long segments. The length of the berms is usually limited to 20 ft for ease of handling.

### *Installation*

- Place the fabric on the bottom of the stream, and place either a bag of clean, washed gravel or a continuous berm over the bottom of the fabric, such that a bag-width of fabric lies on the stream bottom. The bag should be placed on what will be the outside of the isolation area.
- Pull the fabric up, and place a metal t-post immediately behind the fabric, on the inside of the isolation area; attach the fabric to the post with three diagonal nylon ties.
- Continue placing fabric as described above until the entire work area has been isolated, staking the fabric at least every 6 ft.

### *Maintenance and Inspection:*

- During construction and operation, inspect daily during the workweek.
- Schedule additional inspections during storm events.
- Immediately repair any gaps, holes or scour.
- Remove sediment buildup.
- Remove BMP upon completion of construction activity. Recycle or re-use if applicable.

### ***Turbidity Curtain Isolation Technique***

A turbidity curtain (refer to Figures 1A through 1D) is a fabric barrier used to isolate the near shore work area. The barriers are intended to confine the suspended sediment. The curtain is a floating barrier, and thus does not prevent water from entering the isolated area; rather, it prevents suspended sediment from getting out.

### *Appropriate applications:*

Turbidity curtains should be used where sediment discharge to a stream is unavoidable. They are used when construction activities adjoin quiescent waters, such as lakes, ponds, lagoons, bays, and slow flowing rivers. The curtains are designed to deflect and contain sediment within a limited area and provide sufficient retention time so that the soil particles will fall out of suspension.

## *Limitations:*

- Turbidity curtains shall not be used in flowing water; they are best suited for use in ponds, lakes, lagoons, bays, and very slow-moving rivers.
- Turbidity curtains should not be placed across the width of a channel.
- Removing sediment that has been deflected and settled out by the curtain may create a discharge problem through the re-suspension of particles and by accidental dumping by the removal equipment.

## *Standards and Specifications:*

- Turbidity curtains should be oriented parallel to the direction of flow.
- The curtain should extend the entire depth of the watercourse in calm-water situations.
- In wave conditions, the curtain should extend to within 1 ft of the bottom of the watercourse, such that the curtain does not stir up sediment by hitting the bottom repeatedly. If it is desirable for the curtain to reach the bottom in an active-water situation, a pervious filter fabric may be used for the bottom 1 ft.
- The top of the curtain should consist of flexible flotation buoys, and the bottom shall be held down by a load line incorporated into the curtain fabric. The fabric shall be a brightly colored impervious mesh.
- The curtain shall be held in place by anchors placed at least every 100 ft.
- First place the anchors, then tow the fabric out in a furled condition, and connect to the anchors. The anchors should be connected to the flotation devices, and not to the bottom of the curtain. Once in place, cut the furling lines, and allow the bottom of the curtain to sink.
- Sediment that has been deflected and settled out by the curtain may be removed if so directed by the Engineer. Consideration must be given to the probable outcome of the removal procedure. It must be asked if it will create more of a sediment problem through re-suspension of the particles or by accidental dumping of material during removal. It is recommended that the soil particles trapped by the turbidity curtain only be removed if there has been a significant change in the original contours of the affected area in the watercourse.
- Particles should always be allowed to settle for a minimum of 6 to 12 hours prior to their removal or prior to removal of the turbidity curtain.

## *Maintenance and Inspection:*

- The curtain shall be inspected daily for holes or other problems, and any repairs needed should be made promptly.

- Allow sediment to settle for 6 to 12 hours prior to removal of sediment or curtain. This means that after removing sediment, wait an additional 6 to 12 hours before removing the curtain.
- To remove, install furling lines along the curtain, detach from anchors, and tow out of the water.

## ***K-rail River Isolation***

This is temporary sediment control, or stream isolation method that uses K-rails (refer to Figure 2) to form the sediment deposition area, or to isolate the in-stream or near-bank construction area.

Barriers are placed end-to-end in a pre-designed configuration and gravel-filled bags are used at the toe of the barrier and also at their abutting ends to seal and prevent movement of sediment beneath or through the barrier walls.

### *Appropriate Applications:*

- The K-rail isolation can be used in streams with higher water velocities than many other isolation techniques.

### *Limitations:*

- The K-rail method does not allow for full dewatering.

### *Standards and Specifications:*

- To create a floor for the K-rail, move large rocks and obstructions. Place washed gravel and gravel-filled bags to create a level surface for K-rail to sit.
- Place the bottom two K-rails adjacent to each other, and parallel to the direction of flow; fill the center portion with gravel bags. Then place the third K-rail on top of the bottom two; there should be sufficient gravel bags between the bottom K-rails such that the top one is supported by the gravel. Place plastic sheeting around the K-rails, and secure at the bottom with gravel bags.
- Further support can be added by pinning and cabling the K-rails together. Also, large riprap and boulders can be used to support either side of the K-rail, especially where there is strong current.

### *Maintenance and Inspection:*

- The barrier shall be inspected at least once daily, and any damage, movement or other problems should be addressed immediately.
- Sediment should be allowed to settle for at least 6 to 12 hours prior to removal of sediment, and for 6 to 12 hours prior to removal of the barrier.

## ***Stream Diversions***

Stream diversions consist of a system of structures and measures that intercept an existing stream, upstream of the project, and transport it around the work area, and discharge it downstream (refer to Figure 3). The selection of which stream diversion technique to use depends upon the type of work involved, physical characteristics of the site, and the volume of water flowing through the project.

### ***Appropriate Applications:***

- Pumped diversions are appropriate in areas where de-watering is necessary.
- Dam-type diversions may serve as temporary access to the site.
- Where work areas require isolation from flows.

### ***Limitations:***

- Pumped diversions have limited flow capacity.
- Pumped diversions require frequent monitoring of pumps.
- Large flows during storm events can overtop dams.
- Flow diversion and re-direction with small dams involves in-stream disturbance and mobilization of sediment.

### ***Standards and Specifications:***

- Stream diversions shall be constructed only when there are no flowing or ponded water in the streambed.
- Installation guidelines will vary based on existing site conditions and type of diversion used.
- Diversions and pump capacity shall be sized to convey design flows rates.
- Adequate energy dissipation must be provided at the outlet to minimize erosion.
- Dam materials used to create dams upstream and downstream of diversion should be erosion resistant; materials such as steel plate, sheetpile, sandbags, continuous berms, inflatable water bladders, etc. would be acceptable.
- When constructing a diversion channel, begin excavation of the channel at the proposed downstream end, and work upstream. Once the watercourse to be diverted is reached, and the excavated channel is stable, breach the upstream end, and allow water to flow down the new channel. Once flow has been established in the diversion channel, install the diversion weir in the main channel; this will force all water to be diverted from the main channel.

### *Maintenance and Inspection:*

- Inspect diversion/encroachment structures before and after significant storms, and at least once per week while in service. Inspect daily during the construction.
- Pumped diversions require frequent monitoring of pumps.
- Inspect embankments and diversion channels before and after significant storms, and at least once per week while in service for damage to the linings, accumulating debris, sediment buildup, and adequacy of the slope protection. Remove debris and repair linings and slope protection as required. Repair holes, gaps, or scour.
- Upon completion of work, the diversion or isolation structure should be removed and flow should be re-directed through the new culvert or back into the original stream channel. Recycle or re-use if applicable.

BENEFITS/LIMITATIONS

- Allows full dewatering
- Relatively expensive
- Useful in large rivers, lakes, high velocity
- Not really appropriate for small streams
- Requires staging and heavy equipment access areas

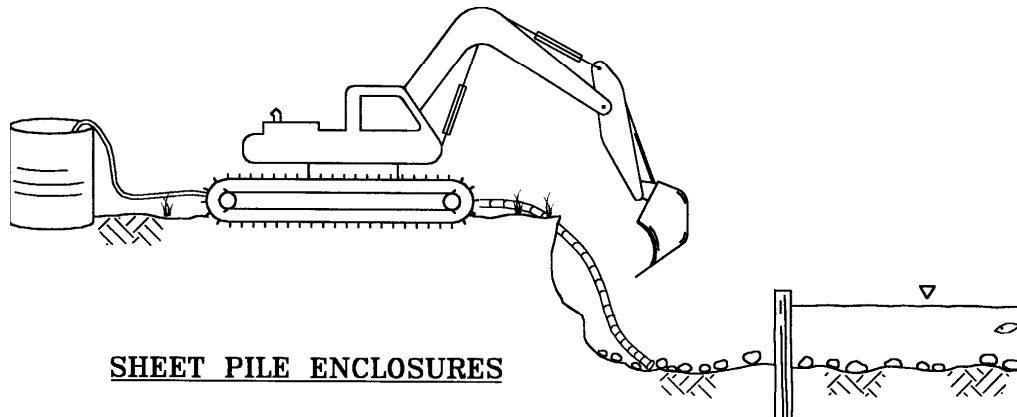

SHEET PILE ENCLOSURES

BENEFITS/LIMITATIONS

- Allows partial dewatering
- Moderately expensive
- Ease of installation and removal unknown
- Can be designed for small streams to large rivers

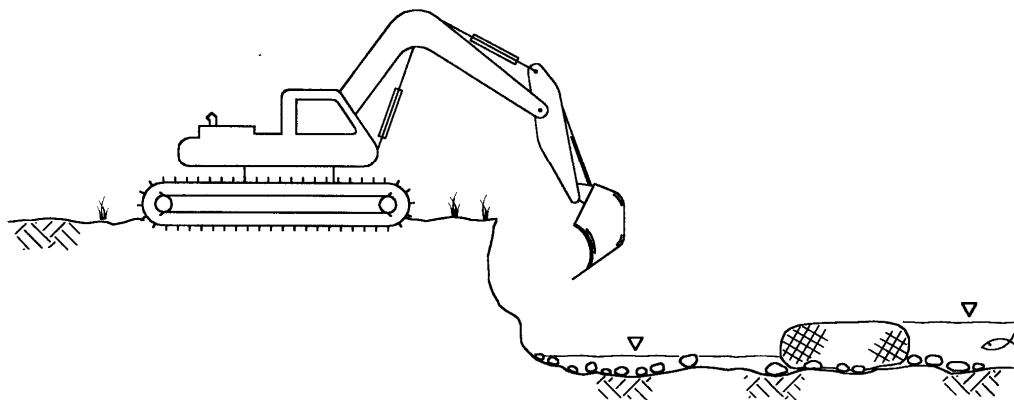

WATER-FILLED GEOTEXTILE (AQUA DAM)

**INSTREAM EROSION AND SEDIMENT CONTROL ISOLATION TECHNIQUES**

**Figure 1A**

### BENEFITS/LIMITATIONS

- Allows partial dewatering
- Relatively inexpensive
- Useful for small streams
- Minimal TSS when removed

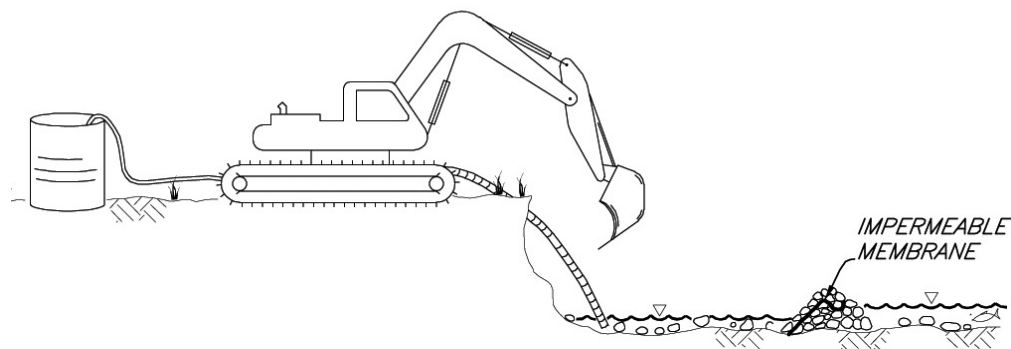

### NOTES:

- Step 1. Install clean gravel with impermeable membrane
- Step 2. Do work
- Step 3. Decommission berm by removing impermeable membrane
- Step 4. Pump work area. Head differential will cause water to flow into work area through gravel
- Step 5. Remove or spread gravel

### GRAVEL BERM WITH IMPERMEABLE MEMBRANE

INSTREAM EROSION AND SEDIMENT  
CONTROL ISOLATION TECHNIQUES

Figure 1B



### BENEFITS/LIMITATIONS

- .Difficult to dewater*
- .Inexpensive*
- .Labor intensive to install and remove*
- .Use clean gravel*

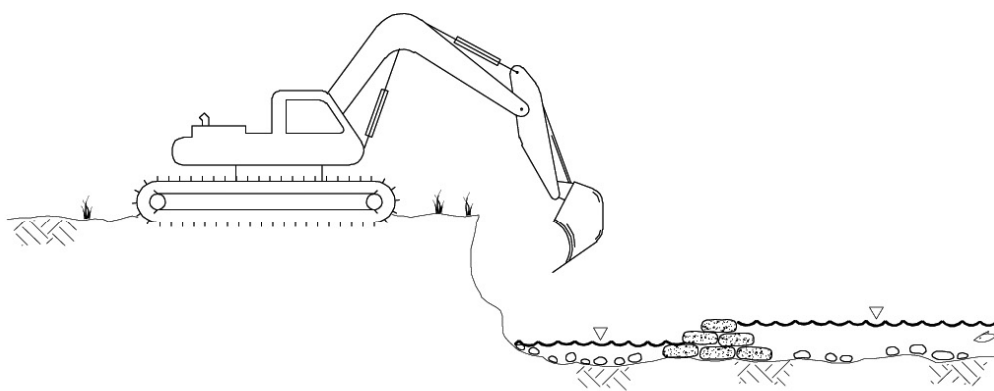

### GRAVEL BAG TECHNIQUE

INSTREAM EROSION AND SEDIMENT  
CONTROL ISOLATION TECHNIQUES

Figure 1C

### *BENEFITS/LIMITATIONS*

- Allows partial dewatering*
- Many different types available*
- Relatively expensive*
- Can be designed for large and small streams*
- Ease of installation and removal unknown*

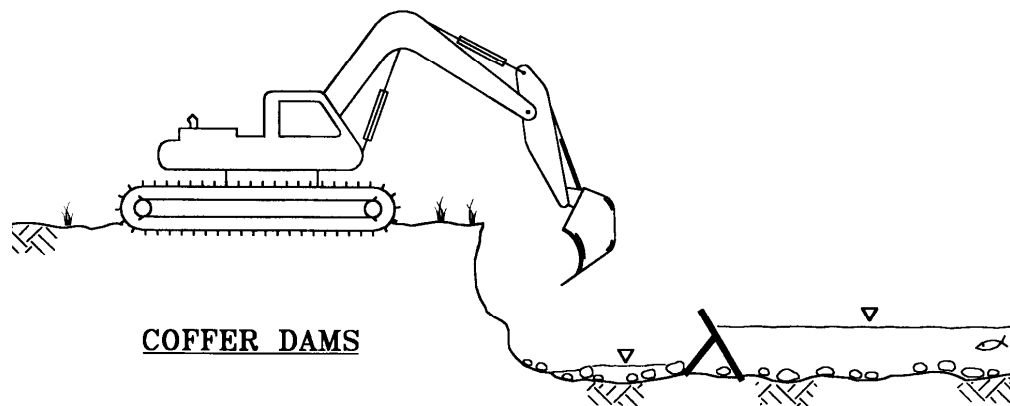

**COFFER DAMS**

### *BENEFITS/LIMITATIONS*

- Does not allow dewatering*
- Inexpensive*
- Used in slow water lakes only*
- Not very effective especially when removing*

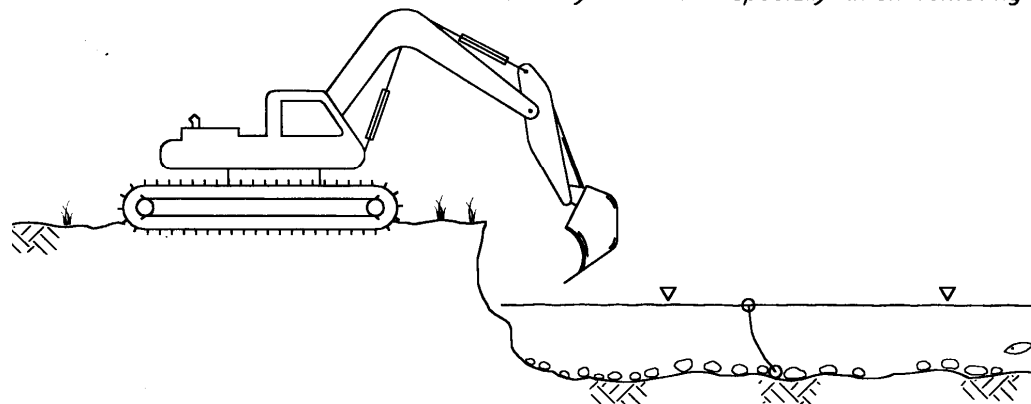

**GEOTEXTILES, SILT BARRIERS, CURTAINS**

## INSTREAM EROSION AND SEDIMENT CONTROL ISOLATION TECHNIQUES

**Figure 1D**

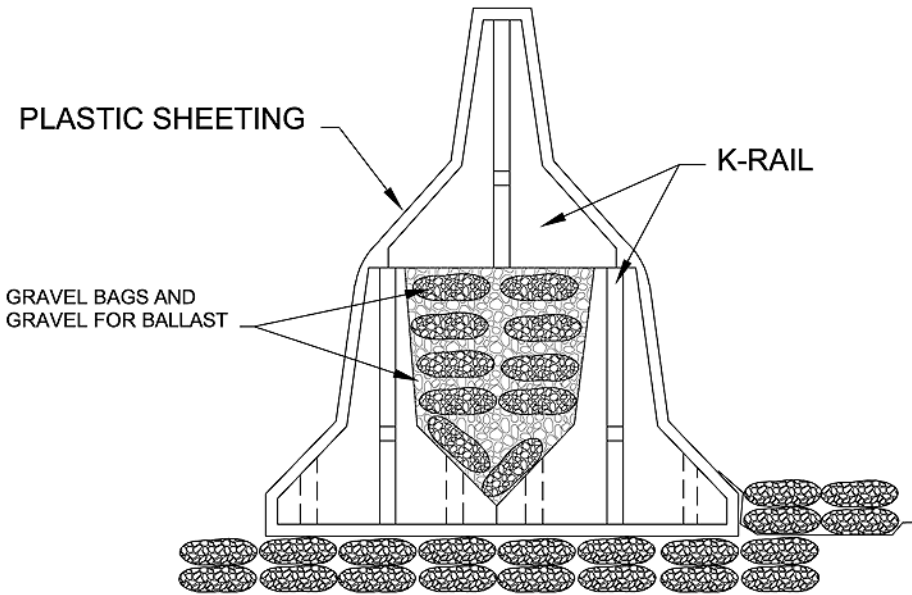

**K-Rail Isolation  
Figure 2**

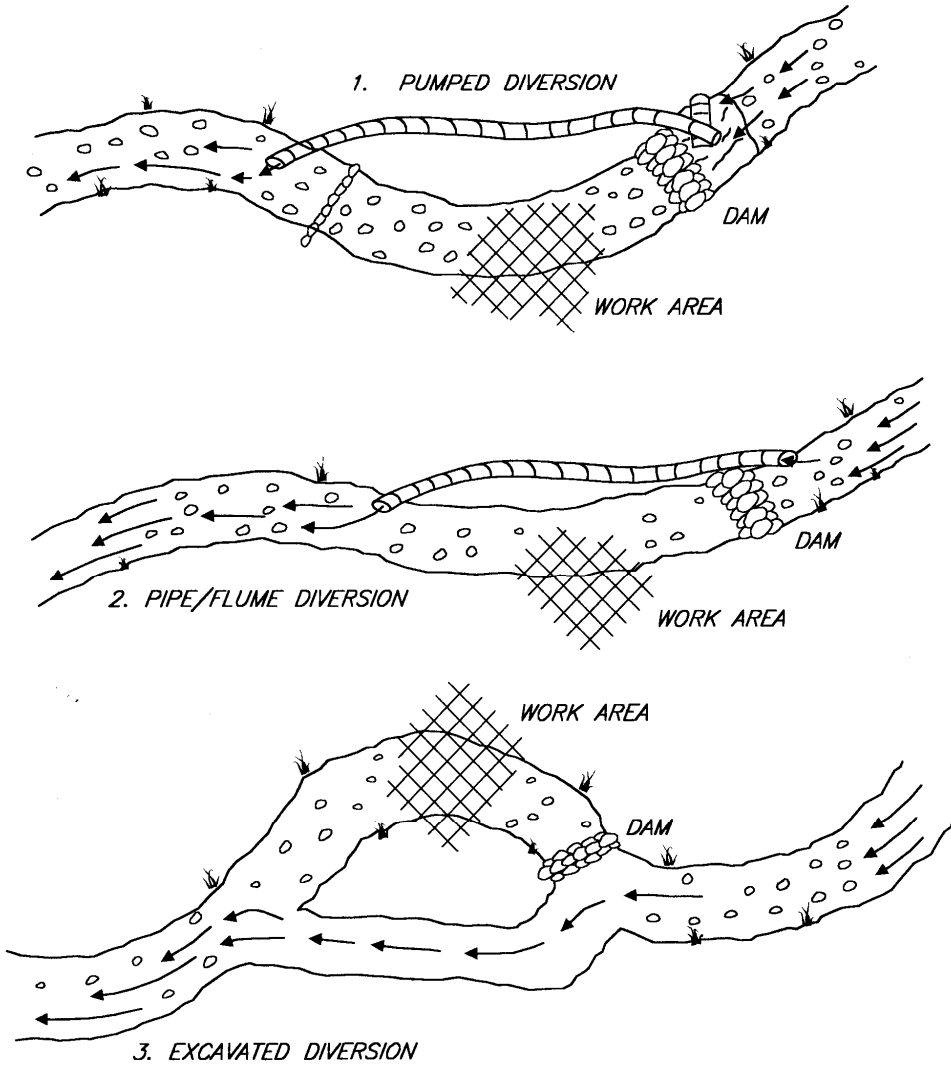

**TYPICAL STREAM  
DIVERSION TECHNIQUES**

**Figure 3**

# Illicit Connection/Illegal Discharge Detection and Reporting

NS-6

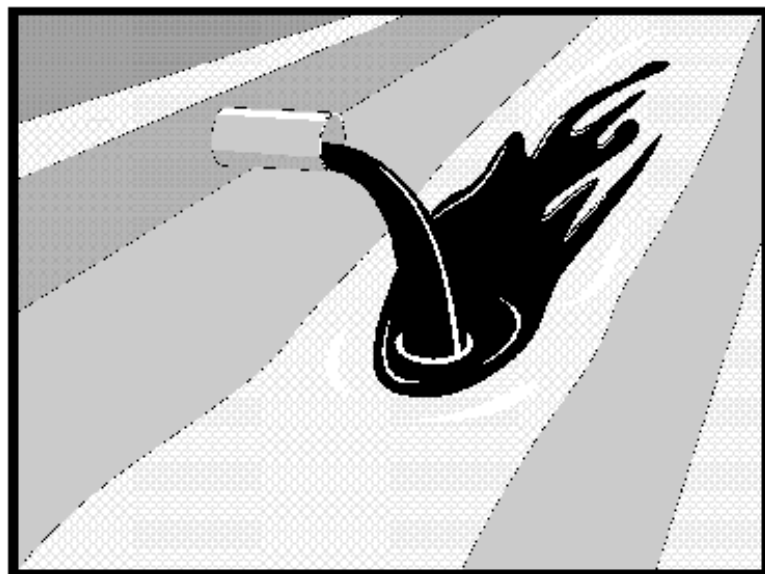

Standard Symbol

### BMP Objectives

- Soil Stabilization
- Sediment Control
- Tracking Control
- Wind Erosion Control
- Non-Storm Water Management
- Materials and Waste Management

**Definition and Purpose** Procedures and practices designed for construction contractors to recognize illicit connections or illegally dumped or discharged materials on a construction site and report incidents to the Engineer.

**Appropriate Applications** Illicit connection/illegal discharge detection and reporting is applicable for all project sites and anytime an illicit connection or discharge is discovered or illegally dumped material is found on the construction site.

Illicit connections and illegal discharges or dumping, for the purposes of this BMP, refer to discharges and dumping caused by parties other than the contractor.

**Limitations** None identified.

- Standards and Specifications**
- Procedures and practices presented in this BMP are general. Contractor shall use extreme caution, immediately notify the Engineer when illicit connections or illegal dumping or discharges are discovered, and take no further action unless directed by the Engineer.
  - If pre-existing hazardous materials or wastes are known to exist onsite, the contractor's responsibility will be detailed in the contract Special Provisions.
  - Inspect construction site before beginning the job for evidence of illicit connections or illegal dumping or discharges.
  - Secure the project site in order to prevent illicit connections or illegal dumping or discharges once construction begins.



# Illicit Connection/Illegal Discharge Detection and Reporting

---

NS-6

- Inspect construction site weekly during project execution for evidence of illicit connections or illegal dumping or discharges.
- Observe construction site perimeter for evidence or potential of illicitly discharged or illegally dumped material, which may enter the construction site.

## ***Identification of Illicit Connections and Illegal Dumping or Discharges***

- Unlabeled or non-identifiable material shall be assumed to be hazardous.
- Solids - Look for debris, or rubbish piles. Solid waste dumping often occurs on roadways with light traffic loads or in areas not easily visible to the public.
- Liquids – signs of illegal liquid dumping or discharge can include:
  - Visible signs of staining or unusual colors to the pavement or surrounding adjacent soils.
  - Pungent odors coming from the drainage systems.
  - Discoloration or oily substances in the water or stains and residues detained within ditches, channels or drain boxes.
  - Abnormal water flow during the dry weather season.
- Urban Areas - Evidence of illicit connections or illegal discharges is typically detected at storm drain outfall locations or at manholes. Signs of an illicit connection or illegal discharge can include:
  - Abnormal water flow during the dry weather season.
  - Unusual flows in subdrain systems used for dewatering.
  - Pungent odors coming from the drainage systems.
  - Discoloration or oily substances in the water or stains and residues detained within ditches, channels or drain boxes.
  - Excessive sediment deposits, particularly adjacent to or near other active construction sites.
- Rural Areas - Illicit connections or illegal discharges involving irrigation drainage ditches are detected by visual inspections. Signs of an illicit discharge can include:
  - Abnormal water flow during the dry weather season.
  - Non-standard junction structures.
  - Broken concrete or other disturbances at or near junction structures.



# Illicit Connection/Illegal Discharge Detection and Reporting

---

NS-6

## ***Reporting***

- Notify the Engineer of any illicit connections and illegal dumping or discharge incidents at the time of discovery.

**Cleanup and Removal** The Agency may direct contractor to clean up non-hazardous dumped or discharged material on the construction site.



(This page left intentionally blank)



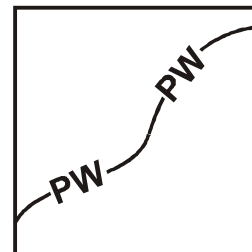
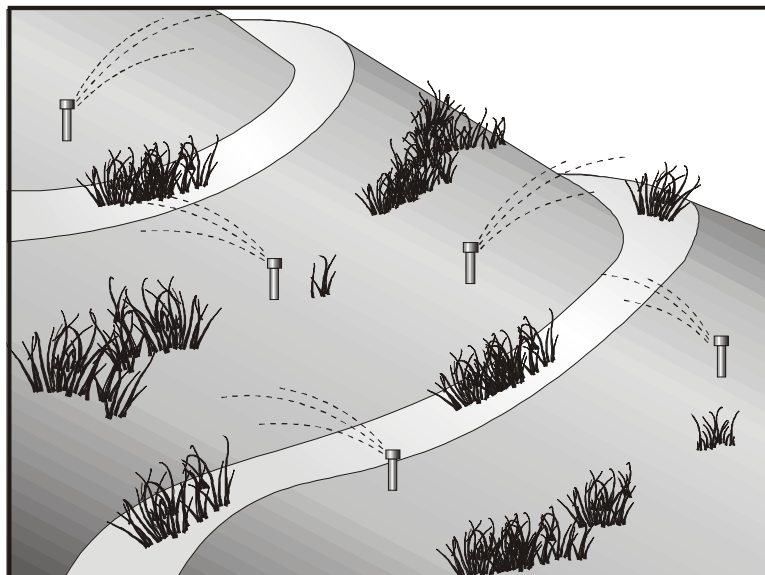

Standard Symbol

- BMP Objectives**

  - Soil Stabilization
  - Sediment Control
  - Tracking Control
  - Wind Erosion Control
  - Non-Storm Water Management
  - Materials and Waste Management

**Definition and Purpose** Potable Water/Irrigation management consists of practices and procedures to manage the discharge of potential pollutants generated during discharges from irrigation water lines, landscape irrigation, lawn or garden watering, planned and unplanned discharges from potable water sources, water line flushing, hydrant flushing and any other water.

**Appropriate Applications** Implement this BMP whenever the above activities or discharges occur or could occur at or enter or run-on to a construction site.

**Limitations** ■ None identified.

- Standards and Specifications**
- Do not allow potable water/irrigation activities to allow discharge to the storm drain system or receiving waters.
  - Engineer approval is required prior to commencing any washing activities that could discharge to a permeable or impermeable surface, the storm drain or receiving waterbody.
  - Shut off the water source to broken lines, sprinklers, or valves as soon as possible to prevent excess water flow.
  - Install appropriate BMPs to protect downstream storm water drainage systems and watercourses from water pumped or bailed from trenches excavated to repair water lines or other reason.
  - Dechlorinate all water lines with a properly neutralizing chemical such as sulfur dioxide, see Appendix B of the American Water Works Association (AWWA) C651. Disposal of heavily chlorinated water shall comply with all applicable law and requirements of Federal, State, County, or other local agencies.

## Maintenance and Inspection

- Inspect potable water and irrigation systems weekly, and before and after every rainfall events. During extended rainfall events, inspect all entrances, exits, access roads at least once every 24 hours.
- Repair broken water lines immediately or as directed by the Engineer.
- Inspect irrigated areas for signs of erosion and/or discharge. If erosion or discharge are observed, take corrective action to stop discharge and erosion immediately or as directed by the Engineer.
- Inspect irrigated areas within the construction limits for excess watering. Adjust watering times and schedules to ensure that the appropriate amount of water is being used and to minimize runoff. Consider factors such as soil structure, grade, time of year, and type of plant material in determining the proper amounts of water for a specific area.



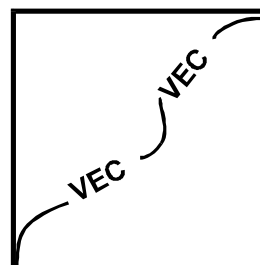
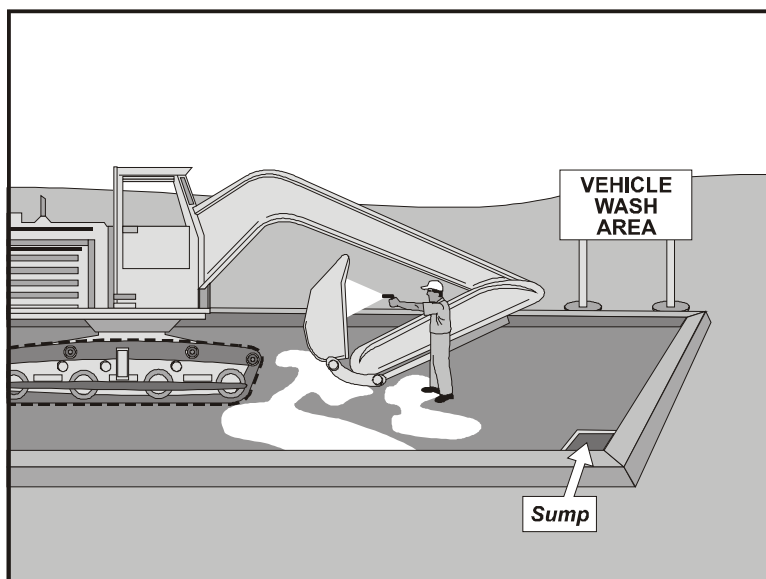

Standard Symbol

### BMP Objectives

- Soil Stabilization
- Sediment Control
- Tracking Control
- Wind Erosion Control
- Non-Storm Water Management
- Materials and Waste Management

**Definition and Purpose** Vehicle and equipment cleaning procedures and practices are used to minimize or eliminate the discharge of pollutants from vehicle and equipment cleaning operations to the ground, storm drain system or to watercourses.

**Appropriate Applications** These procedures are applied on all construction sites where vehicle and equipment cleaning is performed.

**Limitations** ■ Sediment control BMPs (SC-1 through SC-10) are not adequate to prevent the discharge of pollutants generated from vehicle and equipment cleaning.

- Standards and Specifications**
- On-site vehicle and equipment washing is discouraged.
  - Prevent disposal of any rinse or wash waters or materials onto impervious or pervious site surfaces or into the storm drain system or watercourses.
  - Cleaning of vehicles and equipment with soap, solvents or steam shall not occur on the project site unless the Engineer has been notified in advance and the resulting wastes are fully contained and disposed of offsite in conformance with all applicable laws and regulations. Resulting wastes and by-products shall not be discharged or buried and must be captured and recycled or disposed according to the requirements of WM-6, "Hazardous Waste Management," depending on the waste characteristics. Minimize use of solvents. The use of diesel for vehicle and equipment cleaning is prohibited.
  - Vehicle and equipment wash water shall be contained to prevent it from entering the storm drain inlets or watercourses and shall not be discharged on site. Protect drain inlets (SC-10 is not adequate) by covering with plastic to completely block the inlet and do not allow any discharge. Remove plastic after cleaning operations are completed and the water has been disposed of properly.

- All vehicles/equipment that regularly enter and leave the construction site shall be cleaned off-site.
  - Prevent oil, grease or fuel from leaking onto the ground (impervious or pervious site surfaces) or into the storm drains or surface waters.
  - Clean up leaks or spills immediately and dispose of properly in accordance with WM-4.
  - When vehicle/equipment washing/cleaning must occur onsite, cleaning area shall have the following characteristics, and shall be approved by the Engineer:
    - Located away from storm drain inlets, drainage facilities, or watercourses.
    - Paved with concrete or asphalt and bermed to contain wash waters and to prevent run-on and runoff.
    - Configured with a sump to allow collection and disposal of wash water.
    - Wash waters shall not be discharged to storm drains or watercourses.
    - Used only when necessary.
  - When cleaning vehicles/equipment with water:
    - Use as little water as possible. High pressure sprayers may use less water than a hose, and shall be considered.
    - Use positive shutoff valve to minimize water usage.
- Maintenance and Inspection**
- Inspect all entrances, exits, access roads daily and document weekly, and before and after every rainfall events. During extended rainfall events, inspect all entrances, exits, access roads at least once every 24 hours.
  - Monitor employees and subcontractors throughout the duration of the construction project to ensure appropriate practices are being implemented.
  - Remove liquids and sediment as needed or as directed by the Engineer.

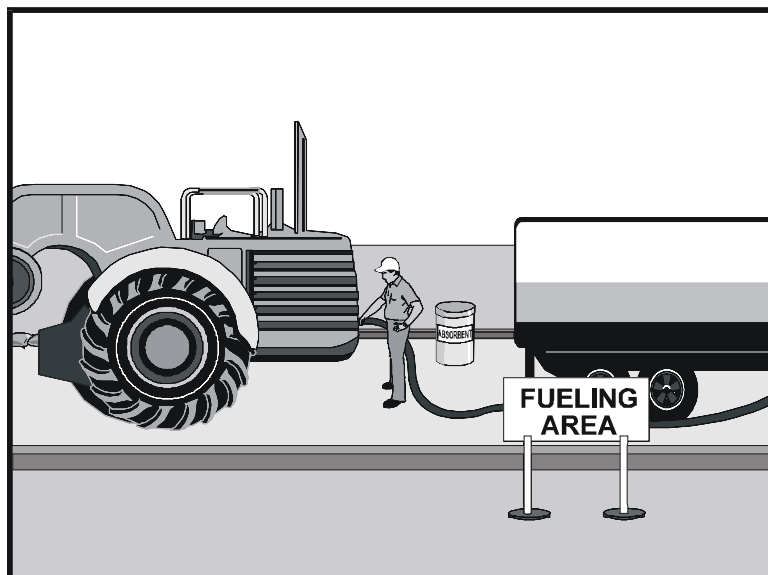

Standard Symbol

### BMP Objectives

- Soil Stabilization
- Sediment Control
- Tracking Control
- Wind Erosion Control
- Non-Storm Water Management
- Materials and Waste Management

**Definition and Purpose** Vehicle and equipment fueling procedures and practices are designed to minimize or eliminate the discharge of fuel spills and leaks onto the ground (impervious or pervious site surfaces) or into storm drain systems or to watercourses.

**Appropriate Applications** These procedures are applied on all construction sites where vehicle and equipment fueling takes place.

**Limitations**

- Onsite vehicle and equipment fueling shall only be used where it's impractical to send vehicles and equipment off-site for fueling.

**Standards and Specifications**

- The contractor shall select and designate an area to be used for fueling. The fueling area shall be identified in the SWPPP or approved by the Engineer for non-SWPPP projects.

- Prevent oil, grease, or fuel to leak in to the ground, offsite, storm drains, surface waters, or water courses.

- Absorbent spill clean-up materials and spill kits shall be available in fueling areas and on fueling trucks and shall be disposed of properly after use.

- Drip pans or absorbent pads shall be used during vehicle and equipment fueling.

- Dedicated fueling areas shall be protected with berms and/or dikes from storm water run-on and runoff, and shall be located at least 50 ft from downstream drainage facilities and watercourses. Fueling must be performed on level-grade areas.

- Nozzles used in vehicle and equipment fueling shall be equipped with an automatic shut-off to control drips and spills. Fueling operations shall not be left unattended.

- Comply with applicable local Air Quality Management District regulations with berms and/or dikes District's (AQMD) regulations. Ensure nozzles are secured upright when not in use.
- Fuel tanks shall not be "topped-off."
- Vehicles and equipment shall be inspected on each day of use for leaks. Leaks shall be repaired immediately or problem vehicles or equipment shall be removed from the project site.
- Absorbent spill clean-up materials shall be available in fueling and maintenance areas and used on small spills instead of hosing down or burying techniques. The spent absorbent material shall be removed promptly and disposed of properly.
- Federal, state, and local requirements shall be observed for any stationary above ground storage tanks. Refer to WM-1, "Material Delivery and Storage."
- Mobile fueling of construction equipment throughout the site shall be minimized. Whenever practical, equipment shall be transported to the designated fueling area.

## Maintenance and Inspection

- Inspect all fueling areas and operations daily and document weekly, and before and after every rainfall events. During extended rainfall events, inspect all entrances, exits, access roads at least once every 24 hours.
- Fueling areas and storage tanks shall be inspected regularly.
- Keep an ample supply of spill cleanup material on the site.
- Immediately cleanup spills and properly dispose of contaminated soil and cleanup materials in accordance with WM-4.

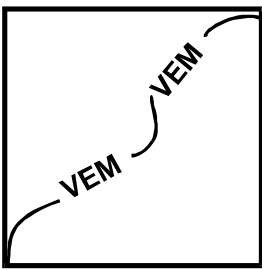
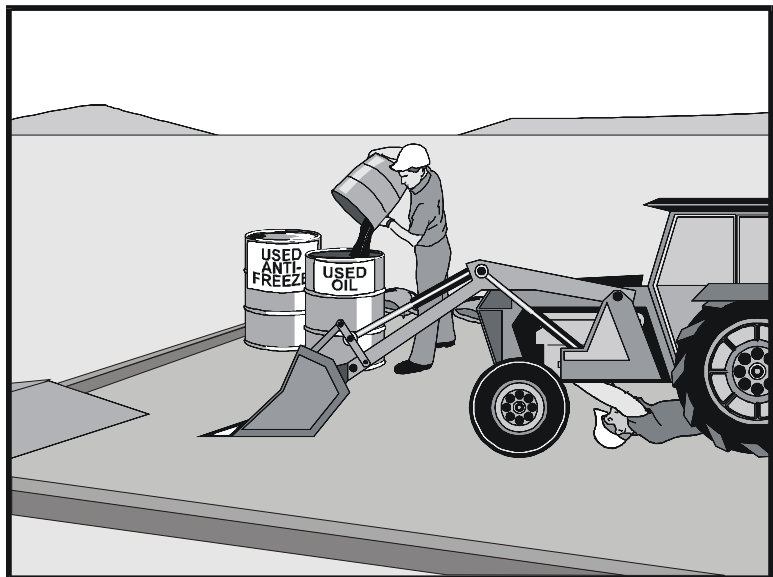

Standard Symbol

- BMP Objectives**
- Soil Stabilization
  - Sediment Control
  - Tracking Control
  - Wind Erosion Control
  - Non-Storm Water Management
  - Materials and Waste Management

**Definition and Purpose** Procedures and practices to minimize or eliminate the discharge of pollutants to the storm drain systems or to watercourses from vehicle and equipment operation, maintenance, and modification procedures.

**Appropriate Applications** These procedures are applied on all construction projects for storage, operation, and maintenance of heavy equipment and vehicles.

**Limitations** ■ None identified.

- Standards and Specifications**
- Place all vehicles or equipment to be maintained or stored in a designated and dedicated area.
  - Use off-site maintenance facilities whenever practical.
  - The vehicles or equipment maintenance and storage areas shall be identified in the SWPPP or approved by the Engineer for non-SWPPP projects.
  - Dedicated maintenance areas shall be protected from storm water run-on and runoff, and shall be located at least 50 ft from downstream drainage facilities and watercourses.
  - Prevent oil, grease, or fuel to leak in to ground (impervious or pervious site surfaces), storm drains, or watercourses.
  - Clean spills and leaks immediately and dispose of leaked materials and cleanup waste properly in accordance with WM-4.
  - Drip pans or absorbent pads shall be used during all vehicle and equipment maintenance work
  - All maintenance areas are required to have spill kits (see WM-4) and/or use other spill protection devices.



- Absorbent spill clean-up materials shall be available in maintenance areas and shall be disposed of properly after use.
- For long-term projects, consider constructing roofs or using portable tents over maintenance areas.
- Properly dispose of used oils, fluids, lubricants, and spill cleanup materials.
- Do not dump oil, fuels and lubricants onto the ground (impervious or pervious site surfaces), storm drain system, or watercourses.
- Properly dispose or recycle used batteries.
- Do not bury used tires.
- Repair fluid and oil leaks immediately.
- Provide spill containment dikes or secondary containment around stored oil and chemical drums per WM-1.

## Maintenance and Inspection

- Inspect all vehicle and equipment maintenance areas weekly, and before and after every rainfall events. During extended rainfall events, inspect all vehicle and equipment maintenance areas at least once every 24 hours.
- Maintain waste fluid containers in leak proof condition.
- Vehicles and equipment shall be inspected on each day of use. Leaks shall be repaired immediately or the problem vehicle(s) or equipment shall be removed from the project site. Spills shall be cleaned up in accordance with BMP WM-04 Spill Prevention and Control.
- Inspect equipment for damaged hoses and leaky gaskets routinely. Repair or replace as needed and clean up any spills or leaks immediately.
- Wastes generated from cleanups shall be disposed of in accordance with BMP WM-04 Spill Prevention and Control in compliance with all applicable laws and regulations.



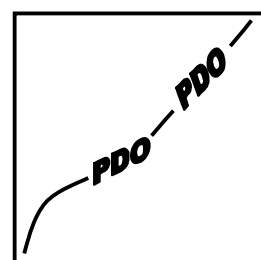
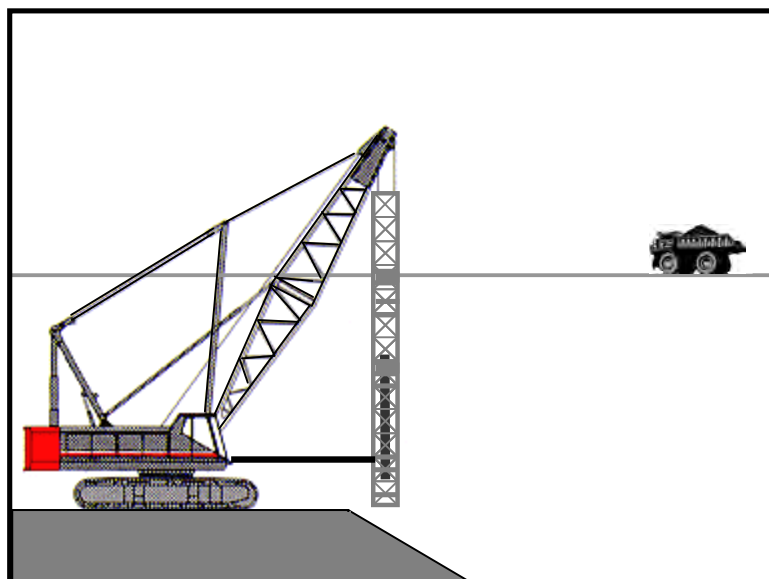

Standard Symbol

- BMP Objectives**

  - Soil Stabilization
  - Sediment Control
  - Tracking Control
  - Wind Erosion Control
  - Non-Storm Water Management
  - Materials and Waste Management

**Definition and Purpose** The construction and retrofit of bridges and retaining walls often include driving piles for foundation support and shoring operations. Driven piles are typically constructed of concrete, steel, or timber. Driven sheet piles are used for shoring and cofferdam construction. Proper control and use of equipment, materials, and waste products from pile driving operations will reduce the discharge of potential pollutants to the storm drain system or watercourses.

**Appropriate Applications** These procedures apply to all construction sites where permanent and temporary pile driving operations (impact and vibratory), including operations using pile shells for construction of cast-in-steel-shell and cast-in-drilled-hole piles.

**Limitations** ■ None identified.

- Standards and Specifications**
- Use drip pans or absorbent pads under all pile driving equipment during use or storage. Plastic sheeting is not a substitute for drip pans or absorbent pads. Refer to BMPs NS-9 “Vehicle and Equipment Fueling” and NS-10 “Vehicle and Equipment Maintenance.”
  - All hydraulic hose connections shall be “capped and bagged” when disconnected.
  - Have spill kits and cleanup materials available at all locations of pile driving. Refer to BMP WM-4 “Spill Prevention and Control.”
  - Implement other BMPs as applicable, such as WM-5 “Solid Waste Management,” WM-6 “Hazardous Waste Management,” and WM-10 “Liquid Waste Management.”
  - When not in use, store pile driving equipment away from concentrated flows of storm water, drainage courses, and inlets. Protect hammers and other hydraulic attachments from run-on by placing them on and covering them with plastic sheeting or a comparable material.

## Maintenance and Inspection

- Use less hazardous products, e.g. vegetable oil instead of hydraulic fluid, when practicable.
- Inspect all pile driving equipment daily and document weekly, and before and after every rainfall events. During extended rainfall events, inspect all pile driving equipment areas at least once every 24 hours.



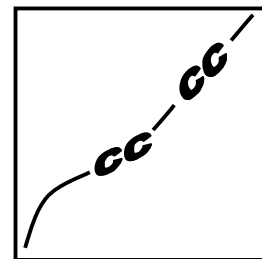
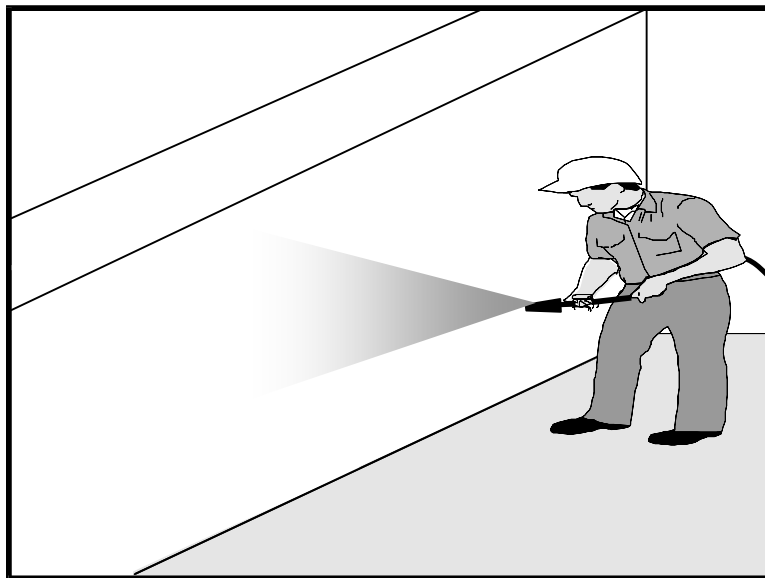

Standard Symbol

### BMP Objectives

- Soil Stabilization
- Sediment Control
- Tracking Control
- Wind Erosion Control
- Non-Storm Water Management
- Materials and Waste Management

**Definition and Purpose** Concrete curing is used in the construction of structures such as bridges, retaining walls, and pump houses. Concrete curing includes the use of both chemical and water methods. Proper procedures minimize pollution of runoff during concrete curing.

**Appropriate Applications** All concrete elements of a structure (e.g., footings, columns, abutments, stems, soffit, deck) are subject to curing requirements.

**Limitations** ■ None identified.

**Standards and Specifications** ***Chemical Curing***

- Prevent over-spray or drift of curing compounds by applying the curing compound close to the concrete surface. Apply an amount of compound that covers the surface, but does not allow any runoff of the compound.
- Use proper storage and handling techniques for concrete curing compounds. Refer to BMP WM-1, “Material Delivery and Storage.”
- Protect drain inlets prior to the application of curing compounds.
- Refer to WM-4, “Spill Prevention and Control.”
- Apply cure water in a manner that does not produce runoff or result in a non-storm-water discharge.
- Prevent cure water from discharging to the ground, storm drain system and watercourses to collection areas for removal as approved by the Engineer and in accordance with all applicable permits, laws and regulations.
- Utilize wet blankets or a similar method that maintains moisture while minimizing the use and possible discharge of water.

- Maintenance and Inspection**
- Inspect all concrete curing operations and equipment weekly, and before and after every rainfall events. During extended rainfall events, inspect all concrete curing operations and equipment at least once every 24 hours.
  - Ensure that employees and subcontractors implement appropriate measures for storage, handling, and use of curing compounds.
  - Inspect cure containers and spraying equipment for leaks. Repair leaks immediately.



# Material and Equipment Use Over Water

NS-13

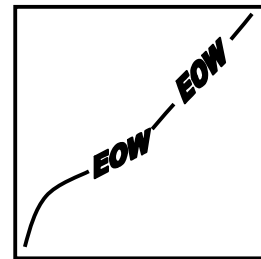
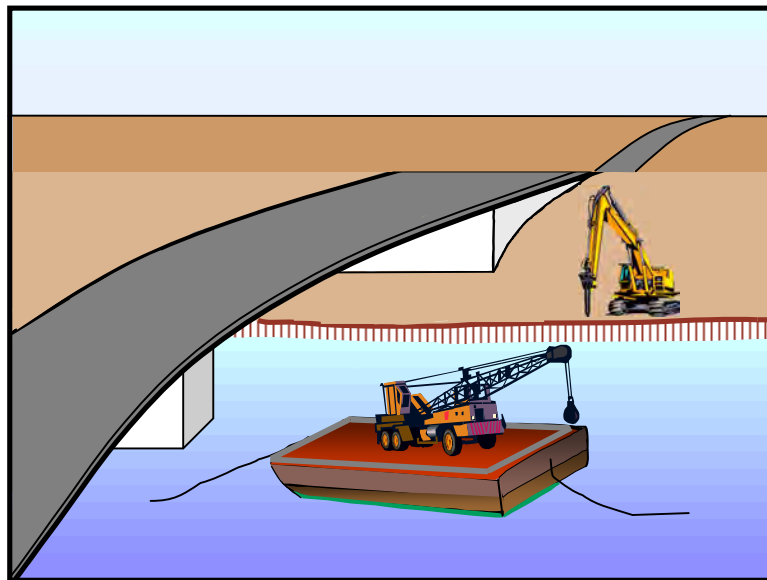

Standard Symbol

- BMP Objectives**
- Soil Stabilization
  - Sediment Control
  - Tracking Control
  - Wind Erosion Control
  - Non-Storm Water Management
  - Materials and Waste Management

**Definition and Purpose** Procedures for the proper use, storage, and disposal of materials and equipment on bridges, barges, boats, temporary construction pads, or similar locations that minimize or eliminate the discharge of potential pollutants to a watercourse.

**Appropriate Applications** These procedures shall be implemented for construction materials and wastes (solid and liquid) and any other materials that may be detrimental if released. Applies where materials and equipment are used on bridges, barges, boats, docks, and other platforms over or adjacent to a watercourse.

**Limitations**

- Fully comply with the specific permit requirements or mitigation measures identified in the contract Special Provisions and all regulatory permits, such as Regional Water Quality Control Board (RWQCB) 401 Certification, U.S. Army Corps of Engineers 404 permit, California Department of Fish and Game Streambed Alteration Agreement, and US Forest Service Permits. Comply with all water quality monitoring and numerical-based water quality standards identified in the contract Special Provisions and all regulatory permits.

**Standards and Specifications**

- The Contractor shall submit to the Engineer a Debris Containment and Collection Plan per the contract Special Provisions for debris produced when working over or adjacent to watercourses.
- If the contract Special Provisions do not contain requirements for a Debris Containment and Collection Plan, then the Contractor shall prepare a Debris Containment and Collection Plan, per this BMP, and submit it to the Engineer for approval prior to conducting any work over a watercourse.
- The Debris Containment and Collection Plan shall be designed by a professional Engineer registered with the State of California. The Debris Containment and Collection Plan shall be included in the SWPPP.



- The Debris Containment and Collection Plan shall contain at a minimum the following information:
  - Debris containment method
  - Diagrammatic Plans showing locations of equipment, drums/bins, and any other containment apparatus
  - Emergency Response and Spill Response Plan
  - Working drawings of any containment system
  - Loads applied to the existing bridge structure by any containment structure
  - Provisions for ventilation and air movement for visibility and worker safety
  - Manufacturers' instructions on the proper use of equipment.
- The debris containment method shall fully contain all water, debris, and visible dust produced. Including all water, debris, and visible dust produced from abrasive blasting or any other blast cleaning methods.
- The containment structure shall be supported with either rigid or flexible supports. The rigid or flexible containment materials on the containment structure shall retain airborne particles, but may allow air flow through the containment materials. Flexible materials shall be supported and fastened to prevent escape of abrasive and blast materials due to whipping from traffic or wind and to maintain the clearances.
- All joints shall be sealed. Sealing may be by overlapping of seams when using flexible materials or by using tape, caulking, or other sealing measures.
- If at any time during the execution of the work, the containment system fails to contain all water, debris, or dust, the Contractor shall immediately suspend all operations except those intended to minimize adverse impact to the environment. Operations shall not resume until modifications have been made to correct the cause of the failure.
- Debris produced when cleaning shall not be temporarily stored on the ground or pavement. Debris accumulated inside the containment system shall be removed before the end of each work shift. Debris shall be stored in approved, leak proof containers and shall be handled in such a manner that no spillage will occur. Do not allow demolished material to enter waterway.
- Drip pans shall be placed under all vehicles and equipment placed on bridges, docks, barges, or other structures over water bodies when the vehicle or equipment is expected to be idle for more than one hour. Ensure that an adequate supply of spill cleanup materials is available.

# Material and Equipment Use Over Water

---

NS-13

- Refer to BMPs WM-1, “Material Delivery and Storage” and WM-4, “Spill Prevention and Control.”
- Maintain equipment in accordance with BMP NS-10, “Vehicle and Equipment Maintenance.” If a leaking line cannot be repaired, remove equipment from over the water and the construction site.
- Provide watertight curbs or toe boards to contain spills and prevent materials, tools, and debris from leaving the bridges, barge, platform, dock, etc.
- Secure all materials to prevent discharges to receiving waters via wind.
- Identify types of spill control measures to be employed, including the storage of such materials and equipment. Ensure that staff are trained regarding the deployment and access of control measures and that measures are being used.
- Comply with all necessary permits required for construction within or near the watercourse, such as RWQCB, U.S. Army Corps of Engineers, Department of Fish and Game and other local permitting agencies.
- Discharges to waterways shall be reported to the Engineer immediately upon discovery. A written discharge notification must follow within 5 days.
- Refer to BMP NS-15, “Structure Demolition/Removal Over or Adjacent to Water.”

## Maintenance and Inspection

- Inspect materials and equipment and containment methods daily and document weekly and before and after rainfall events. During extended rainfall events, inspect materials and equipment and containment methods at least every 24 hours.
- Inspect equipment for leaks and spills on a daily basis. Repair leaks and clean up spills immediately.
- Ensure that employees and subcontractors implement appropriate measures for storage and use of materials and equipment.
- Inspect and maintain all associated BMPs and perimeter controls to ensure continuous protection of the watercourse.



(This page left intentionally blank)



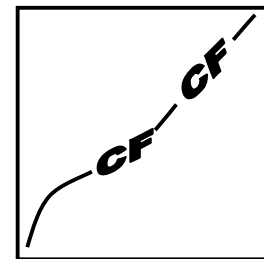
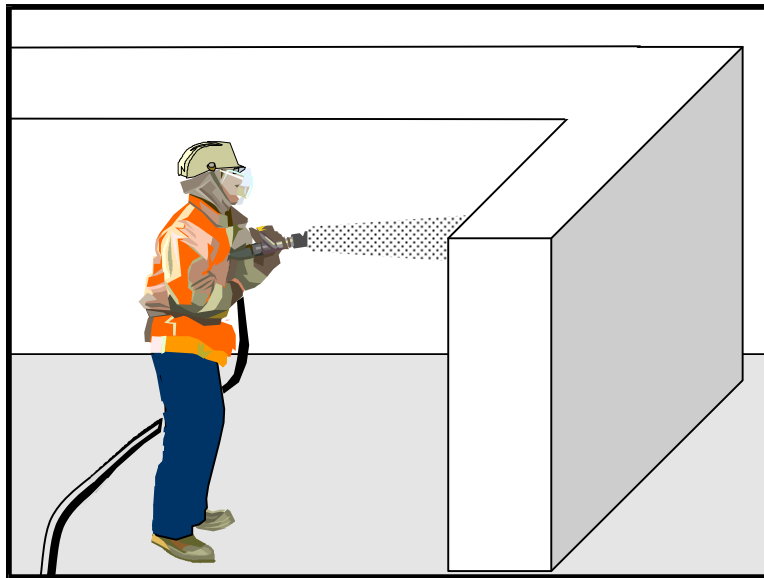

Standard Symbol

### BMP Objectives

- Soil Stabilization
- Sediment Control
- Tracking Control
- Wind Erosion Control
- Non-Storm Water Management
- Materials and Waste Management

**Definition and Purpose** Concrete finishing methods are used for bridge deck rehabilitation, paint removal, curing compound removal, final surface finish appearances, and other construction operations that remove or add to concrete surfaces. Methods include sand blasting, shot blasting, grinding, high pressure water blasting, or other method. Proper procedures minimize the impact that concrete finishing methods may have on runoff.

**Appropriate Applications** These procedures apply to all construction sites where concrete finishing operations are performed.

**Limitations** ■ None identified

- Standards and Specifications**
- If the contract Special Provisions do not contain requirements for a Debris Containment and Collection Plan, then the Contractor shall prepare a Debris Containment and Collection Plan, per this BMP, and submit it to the Engineer for approval prior to conducting any work over a watercourse.
  - Submit MSDS of all shot blasting material not previously disclosed in submittals to the Engineer for approval 7 days prior to operation.
  - Collect and properly dispose of water and solid waste from high-pressure water blasting operations in accordance with spill disposal procedures in WM-4.
  - Do not allow slag or other shot blasting material to contact the soil or surrounding areas. Protect all areas with plastic sheeting to prevent discharge to soil or surrounding areas.
  - Protect inlets during sandblasting operations by covering them with filter fabric during finishing operations.

- Refer to BMP WM-8, “Concrete Waste Management.”
- Minimize the drift of dust and blast material as much as possible by keeping the blasting nozzle close to the surface.
- When blast residue contains a potentially hazardous waste, refer to BMP WM-6, “Hazardous Waste Management.”
- Debris produced when cleaning shall not be temporarily stored on the ground or pavement. Debris accumulated inside the containment system shall be removed before the end of each work shift. Debris shall be stored in approved, leak proof containers and shall be handled in such a manner that no spillage will occur.
- The Contractor shall disposed of the debris generated at a facility equipped to recycle the debris, is subject to the following requirements:
  - An exclusively recyclable material (ERM) such as Copper slag abrasive blended by the supplier with a calcium silicate compound shall be used for blast cleaning.
  - If cleaning or finishing metal surfaces, the debris produced shall be tested by using Title 22 of the California Code of Regulations CAM Metals Method, and 40 CFR Part 268 Method. The Contractor to confirm that the Soluble Threshold Limit Concentrations (STLC), the Total Threshold Limit Concentrations (TTLC), and the Toxicity Characteristic Leaching Procedure (TCLP) of the heavy metals are below regulatory limits and the debris may be transported to the recycling facility as a non-hazardous waste.
  - The Contractor shall make all arrangements with the recycling facility and perform any testing required by the recycling facility operator, or in compliance with regulations.
  - The Contractor shall specify to the Agency, the name, location and Statement of Qualifications (SOQs) of the recycling facility for review and approval by the Agency.

## Maintenance and Inspection

- Inspect concrete finishing operations weekly and before and after rainfall events. During extended rainfall events, inspect concrete finishing operations at least every 24 hours.

# Structure Demolition/Removal Over or Adjacent to Water

NS-15

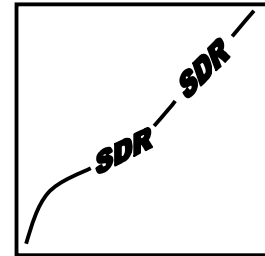
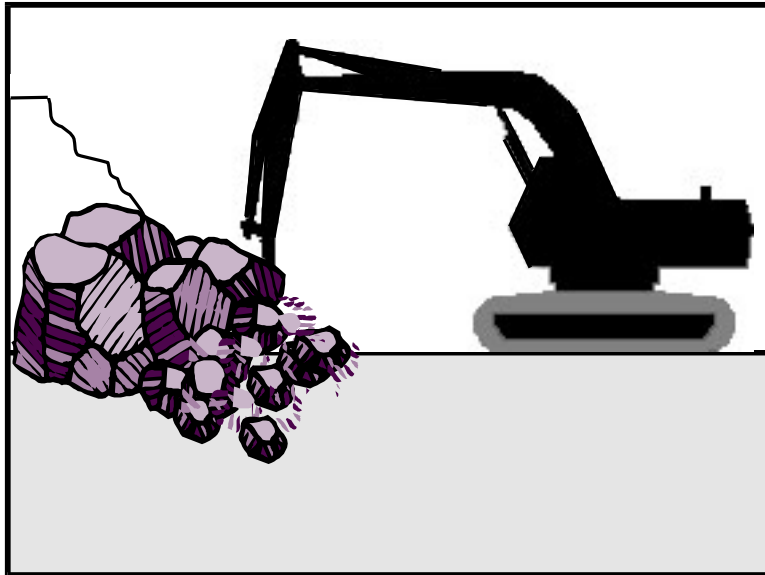

Standard Symbol

### BMP Objectives

- Soil Stabilization
- Sediment Control
- Tracking Control
- Wind Erosion Control
- Non-Storm Water Management
- Materials and Waste Management

**Definition and Purpose** Procedures to protect water bodies from debris and wastes associated with structure demolition or removal over or adjacent to watercourses.

**Appropriate Applications** Full bridge demolition and removal, partial bridge removal (e.g., barrier rail, edge of deck), concrete channel removal, outfall structure construction/repair, or any other structure removal that could potentially affect water quality.

**Limitations**

- Fully comply with the specific permit requirements or mitigation measures identified in the contract Special Provisions and all regulatory permits, such as Regional Water Quality Control Board (RWQCB) 401 Certification, U.S. Army Corps of Engineers 404 permit, California Department of Fish and Game Streambed Alteration Agreement, and US Forest Service Permits. Comply with all water quality monitoring and numerical-based water quality standards identified in the contract Special Provisions and all regulatory permits.

**Standards and Specifications**

- The Contractor shall submit to the Engineer a Debris Containment and Collection Plan per the contract Special Provisions for debris produced when working over or adjacent to watercourses.
- If the contract Special Provisions do not contain requirements for a Debris Containment and Collection Plan, then the Contractor shall prepare a Debris Containment and Collection Plan, per this BMP, and submit it to the Engineer for approval prior to conducting any work over a watercourse.
- The Debris Containment and Collection Plan shall be designed by a professional Engineer registered with the State of California. The Debris Containment and Collection Plan shall be included in the SWPPP.



# Structure Demolition/Removal Over or Adjacent to Water

---

NS-15

- The Debris Containment and Collection Plan shall contain at a minimum the following information:
  - Debris containment method
  - Diagrammatic Plans showing locations of equipment, drums/bins, and any other containment apparatus
  - Emergency Response and Spill Response Plan
  - Working drawings of any containment system
  - Loads applied to the existing bridge structure by any containment structure
  - Provisions for ventilation and air movement for visibility and worker safety
  - Manufacturers' instructions on the proper use of equipment.
- The debris containment method shall fully contain all water, debris, and visible dust produced. Including all water, debris, and visible dust produced from abrasive blasting or any other blast cleaning methods.
- The containment structure shall be supported with either rigid or flexible supports. The rigid or flexible containment materials on the containment structure shall retain airborne particles, but may allow air flow through the containment materials. Flexible materials shall be supported and fastened to prevent escape of abrasive and blast materials due to whipping from traffic or wind and to maintain the clearances.
- All joints shall be sealed. Sealing may be by overlapping of seams when using flexible materials or by using tape, caulking, or other sealing measures.
- If at any time during the execution of the work, the containment system fails to contain all water, debris, or dust, the Contractor shall immediately suspend all operations except those intended to minimize adverse impact to the environment. Operations shall not resume until modifications have been made to correct the cause of the failure.
- Debris produced when cleaning shall not be temporarily stored on the ground or pavement. Debris accumulated inside the containment system shall be removed before the end of each work shift. Debris shall be stored in approved, leak proof containers and shall be handled in such a manner that no spillage will occur. Do not allow demolished material to enter waterway.
- Refer to BMPs WM-1, "Material Delivery and Storage" and WM-4, "Spill Prevention and Control."
- Drip pans shall be placed under all vehicles and equipment placed on bridges, docks, barges, or other structures over water bodies when the vehicle or equipment is expected to be idle for more than one hour. Ensure that an adequate supply of spill cleanup materials is available.



# Structure Demolition/Removal Over or Adjacent to Water

---

NS-15

- Maintain equipment in accordance with BMP NS-10, “Vehicle and Equipment Maintenance.” If a leaking line cannot be repaired, remove equipment from over the water and the construction site.
- Refer to BMP NS-5, “Clear Water Diversion” to direct water away from work areas.
- Use attachments on construction equipment such as backhoes to catch debris from small demolition operations.
- Stockpile accumulated debris and waste generated during demolition away from watercourses and in accordance with BMP WM-3, “Stockpile Management.”
- Ensure safe passage of wildlife, as necessary.
- Discharges to waterways shall be reported to the Engineer immediately upon discovery. A written discharge notification must follow within 5 days.
- For structures containing hazardous materials (e.g., lead paint or asbestos) refer to BMP WM-6, “Hazardous Waste Management.” For demolition work involving soil excavation around lead-painted structures, refer to BMP WM-7, “Contaminated Soil Management.”

## ***Ventilated Containment Structure***

- Multiple flap overlapping door tarps shall be used at entry ways to the ventilated containment structure to prevent dust or debris from escaping.
- Baffles, louvers, flapper seals or ducts shall be used at make-up air entry points to the ventilated containment structure to prevent escape of abrasives and resulting surface preparation debris.
- The ventilation system in the ventilated containment structure shall be of the forced input air flow type with fans or blowers.
- Negative air pressure shall be employed within the ventilated containment structure and will be verified by visual methods by observing the concave nature of the containment materials while taking into account wind effects or by using non-hazardous smoke or other visible means to observe air flow. The input air flow shall be properly balanced with the exhaust capacity throughout the range of operations.
- The exhaust air flow of the ventilation system in the ventilated containment structure shall be forced into dust collectors (wet or dry) or bag houses with HEPA collection efficiency.



# Structure Demolition/Removal Over or Adjacent to Water

---

NS-15

- Maintenance and Inspection
- Inspect containment methods daily and document weekly and before and after rainfall events. During extended rainfall events, inspect containment methods at least every 24 hours.
  - Any debris-catching devices shall be emptied regularly. Collected debris shall be removed and stored away from the watercourse and protected from run-on and runoff.



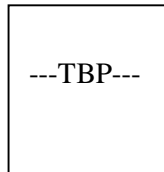

**Standard Symbol**

- B M P Objectives**
- Soil Stabilization
  - Sediment Control
  - Tracking Control
  - Wind Erosion Control
  - Non-Storm Water Management
  - Materials and Waste Management

**Definition and Purpose**

A temporary batch plant is often needed during the construction of roads, bridges, and other large structures in remote areas. Their purpose is for the manufacture of Portland Cement Concrete (PCC), asphalt concrete (AC), slurries, and grouts. These temporary facilities generally consist of fly ash, lime, and cement; heated tanks of liquid asphalt; sand and gravel material storage areas; mixing equipment; above ground storage tanks for concrete additives and water; and designated areas for sand and gravel truck unloading, concrete truck loading, and concrete truck washout. Proper control and use of equipment, materials, and waste will reduce the discharge of potential pollutants to the underlying ground or surrounding areas, offsite, to the storm drain system or watercourses, reduce air emissions, and mitigate noise impacts.

**Appropriate Applications**

These controls are required on construction sites where temporary batch plant facilities are employed.

**Limitations**

■

**Standards and Specifications**

**General Requirements**

- Temporary batch plants may be subject to the General Industrial NPDES Permit. Compliance with this permit requires the submittal of a Notice of Intent (NOI) to the State Water Resources Control Board (SWRCB).
- Proper planning, design, and construction of the facilities shall be implemented to minimize potential water quality, air quality, and noise impacts associated with the use of temporary batch plants.
- Temporary batch plant shall comply with all County or City ordinances, the Air Resources Board (ARB), Air Quality Management District (AQMD), and Regional Water Quality Control Board (RWQCB) may require alternative mitigation measures for temporary batch plants.
- Temporary batch plants shall be managed to comply with AQMD Portable Equipment Registration requirements, South Coast AQMD Rule 403.

## ***Location and Design***

- Temporary batch plants and access roads shall be properly located and designed to reduce water quality impacts to receiving water bodies. Batch plants shall be located a minimum of 50 feet from watercourses, drainage courses, and drain inlets. Batch plants shall be located to minimize the potential for storm water to run onto the site.
- Construct continuous interior AC or PCC berms around the batch plant equipment to facilitate proper run-on, containment and cleanup of releases. Rollover or flip top curb or dikes shall be placed at entrance and exit points.
- Direct runoff from the paved portion of the batch plants into a sump and pipe to a lined washout area or dewatering tank.
- Direct storm water and non-storm water runoff from unpaved portions of the batch plant facility to catchment ponds or tanks.
- Construct and remove concrete washout facilities in accordance with WM-8, Concrete Waste Management.
- A recommended layout of a typical batch plant and associated BMPs is located at the end of this BMP description sheet. If the layout planned is different than attached layout, a complete drawing shall be submitted to the engineer for approval.

## ***Operational Requirements***

- Washout of concrete trucks shall be conducted in a designated area, in accordance with WM-8, Concrete Waste Management.
- Do not dispose of concrete offsite or into drain inlets, the storm water drainage system, or watercourses. There shall be no discharge, spills or leaks of concrete waste into the underlying soil or onto surrounding areas.
- Equipment washing shall occur in a designated area in accordance with WM-8. Washing equipment, tools, or vehicles for removal of PCC shall be conducted in accordance with non-storm water management BMPs, NS-7, Potable Water/Irrigation, an NS-8, Vehicle and Equipment Cleaning.
- All dry material transfer points shall be ducted through a fabric or cartridge type filter unless there are no visible emissions from the transfer plant.
- Equip all bulk storage silos, including auxiliary bulk trailers, with a fabric or cartridge type filters.
- Maintain silo vent filters in proper operating condition.
- Equip silos and auxiliary bulk storage trailers with dust-tight service hatches.
- Fabric dust collectors (except for vent filters) shall be equipped with an operational pressure differential gauge to measure the pressure drop across





the filters.

- All transfer points shall be equipped with a wet suppression system to control fugitive particulate emissions unless there are no visible emissions.
- There shall be no visible emissions beyond the property line, while the equipment is being operated.
- Collect dust emissions from the loading of open-bodied trucks at the drip point of dry batch plants, or dust emissions from the drum feed for central mix plants.
- Equip silos and auxiliary bulk storage trailers with a visible and/or audible warning mechanism to warn operators that the silo or trailer is full.
- All open-bodied vehicles transporting material shall be loaded with a final layer of wet sand and the truck shall be covered with a tarp to reduce emissions.

### ***Tracking Controls***

- Related roads (batch truck and material delivery truck roads) and areas between stockpiles and conveyor hoppers shall be stabilized (TC-2, Stabilized Construction Roadway), or paved with a cohesive hard surface that can be repeatedly swept, maintained intact, and cleaned as necessary to control dust emissions.
- Trucks shall not track PCC from plants onto public roads. Use appropriate practices from TC-1 Stabilized Construction Entrance/Exit and/or TC-3 Entrance/Outlet Tire Wash, to prevent tracking of sediment from the site.

### ***Material Storage Controls***

- BMP WM-1, Material Delivery and Storage, shall be implemented at all batch plants using concrete components or compounds. Cover and contain materials as required by the contract Special Provisions.
- BMP WM-2, Material Use shall be conducted in a way to prevent the discharge of materials to the storm drain system or watercourses.
- Prevent finer materials from being dispersed into the air during operations, such as unloading of cement delivery trucks.
- Stockpiles shall be covered and bermed with perimeter sediment barriers per WM-3, Stockpile Management. Provide secondary containment for all liquid materials (as per WM-1). Handle solid and liquid waste in accordance with WM-5, Solid Waste Management, WM-10, Liquid Waste Management, and WM-8, Concrete Waste Management.
- Maintain adequate supplies of spill cleanup materials and train staff to respond to spills per WM-4, Spill Prevention and Control.

- Immediately clean up spilled cement and fly ash and contain or dampen so that dust or emissions from wind erosion or vehicle traffic are minimized.

### ***Equipment Maintenance BMPs***

- Equipment shall be maintained to prevent fluid leaks and spills per NS-9, Vehicle and Equipment Fueling, and NS-10, Vehicle and Equipment Maintenance.
- Incorporate other BMPs such as WM-5, Solid Waste Management, WM-6, Hazardous Waste Management, and WM-10, Liquid Waste Management.

### **Maintenance and Inspection**

- Inspect all components of the temporary batch plant operations and equipment weekly, and before and after every rainfall events. During extended rainfall events, inspect all components of the temporary batch plant operations and equipment at least once every 24 hours.
- Inspect and verify that controls are in place prior to the commencement of associated activities.
- Inspect and repair equipment, including damaged hoses, fittings, and gaskets.

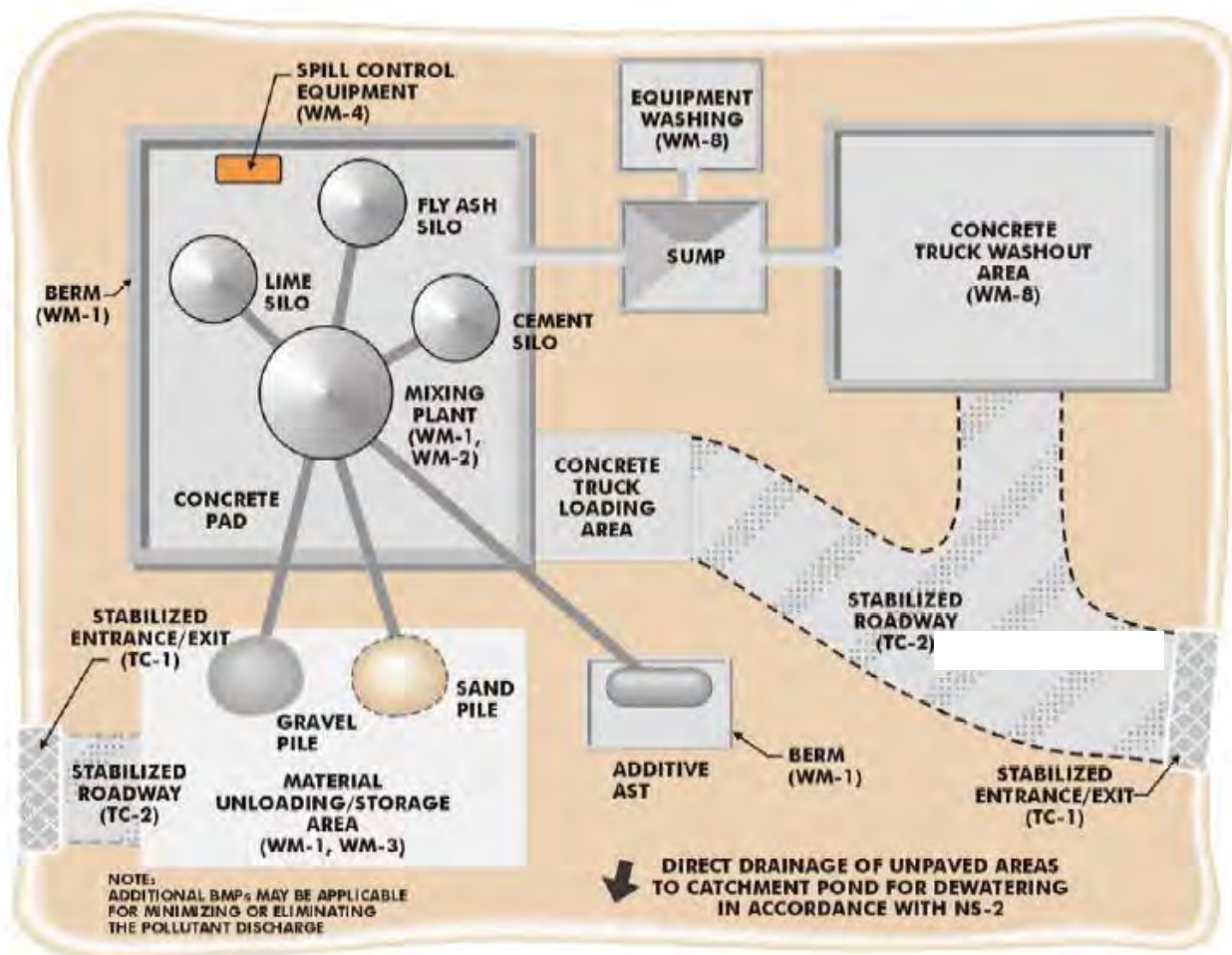

**Typical Temporary Batch**

(This page left intentionally blank)

# SECTION 8

## WASTE MANAGEMENT AND MATERIAL POLLUTION CONTROL BMPs

Waste management and material pollution control BMPs consist of source control measures to prevent non-storm water pollution by limiting or preventing potential pollutants at the source before they come into contact with storm water. These waste management and material pollution control BMPs are also referred to as “good housekeeping practices” which involve day-to-day operations of the construction site and contractor’s yard in order to maintain a clean, orderly, and safe construction site. Waste Management and Material Pollution Control BMPs are shown on Table 8-1.

<b>Table 8-1 Waste Management and Material Pollution Control BMPs</b>	
<b>ID</b>	<b>BMP Name</b>
<b>Material Pollution Control</b>	
WM-1	Material Delivery and Storage
WM-2	Material Use
WM-3	Stockpile Management
<b>Waste Management</b>	
WM-4	Spill Prevention and Control
WM-5	Solid Waste Management
WM-6	Hazardous Waste Management
WM-7	Contaminated Soil Management
WM-8	Concrete Waste Management
WM-9	Sanitary/Septic Waste Management
WM-10	Liquid Waste Management

### 8.1. Material Pollution Control BMPs

Material pollution control BMPs (also referred as materials handling) consist of implementing procedural and structural BMPs for the handling, storage, and use of construction material to prevent the discharge of those materials to the ground, paved surfaces, storm drain system or watercourses. The objective of material pollution control BMPs is to limit or prevent potential pollutants at the source before they come into contact with storm water and prevent contamination to the underlying soil.

### 8.2. Waste Management BMPs

Waste management BMPs consists of implementing procedural and structural BMPs for the handling, storage, and disposal of construction waste to prevent the release of those wastes to the storm drain system or watercourses. The objective of waste management BMPs is to limit or prevent potential pollutants at the source before they come into contact with storm water and prevent contamination to the underlying soil..

### **8.2.1 Hazardous Waste Management**

The handling, storage, and disposal of all hazardous waste or other waste that requires special handling shall be in full compliance with the contract Special Provisions. All Contractor operations shall be in full compliance with the all applicable laws and regulations that govern the management of hazardous and other waste.

If suspected hazardous waste or other waste that requires special handling is encountered on the construction site and the contract Special Provisions do **not** include provisions for the management of such waste, the Contractor shall immediately notify the Engineer for direction.

### **8.2.2 Contaminated Soil Management**

The handling, storage, and disposal of all contaminated soil shall be in full compliance with the contract Special Provisions. All Contractor operations shall be in full compliance with all applicable laws and regulations that govern the management of contaminated soil.

If suspected contaminated soil is encountered on the construction site and the contract Special Provisions do **not** include provisions for the management of contaminated soil, the Contractor shall immediately notify the Engineer for direction.

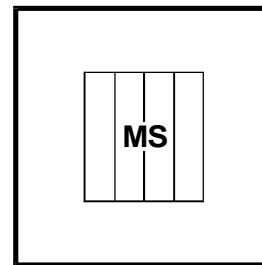
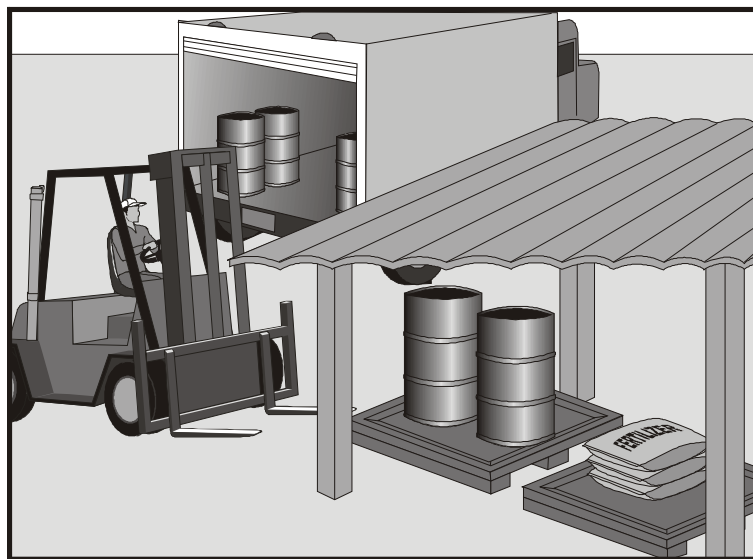

Standard Symbol

### BMP Objectives

- Soil Stabilization
- Sediment Control
- Tracking Control
- Wind Erosion Control
- Non-Storm Water Management
- Materials and Waste Management

**Definition and Purpose** Procedures and practices for the proper handling and storage of materials in a manner that minimizes or eliminates the discharge of these materials to the ground, storm drain system or to watercourses.

**Appropriate Applications** These procedures are implemented at all construction sites with delivery and storage of but not limited to the following:

- Hazardous chemicals such as:
  - Acids/limes
  - glues,
  - adhesives,
  - paints/solvents, and
  - curing compounds.
- Soil stabilizers and binders.
- Fertilizers.
- Detergents.
- Plaster.
- Petroleum products such as fuel, oil, and grease.
- Asphalt and concrete components.
- Pesticides and herbicides.
- Other materials that may be detrimental if released to the environment.

Limitations None identified.

Standards and Specifications

**General**

- Train employees and subcontractors on the proper material delivery and storage practices.
- Temporary storage areas shall be located away from vehicular traffic.
- Material Safety Data Sheets (MSDS) shall be supplied to the Engineer for all materials stored or used on the project.

**Material Storage Areas and Practices**

- Store chemicals in watertight containers (with appropriate secondary containment to prevent any spillage or leakage) or in a storage shed (completely enclosed).
- Minimize exposure of construction materials to precipitation.
- Liquids, petroleum products, and substances listed in 40 CFR Parts 110, 117, or 302 shall be stored in approved containers and drums and shall be placed in temporary containment facilities for storage.
- Each temporary containment facility shall have a permanent cover and side wind protection or be covered when not being used and prior to and during rain events.
- A temporary containment facility shall provide for a spill containment volume able to contain precipitation from a 24-hour, 25-year storm event, plus 110% of the capacity of the largest container within its boundary.
- A temporary containment facility shall be impervious to the materials stored therein for a minimum contact time of 72 hours.
- A temporary containment facility shall be maintained free of accumulated rainwater and spills. In the event of spills or leaks, accumulated rainwater and spills shall be collected and placed into drums. These liquids shall be handled as a hazardous waste unless testing determines them to be non-hazardous. All collected liquids or non-hazardous liquids shall be sent to an approved disposal site in accordance with WM-5 and WM-6.
- Sufficient separation shall be provided between stored containers to allow for spill cleanup and emergency response access.
- Incompatible materials, such as chlorine and ammonia, shall not be stored in the same temporary containment facility.
- Materials shall be stored in their original containers and the original product labels shall be maintained in place in a legible condition. Damaged or otherwise illegible labels shall be replaced immediately. Unlabeled containers





shall not be stored onsite and shall be disposed of immediately in accordance with WM-5 and WM-6.

- Bagged and boxed materials shall be stored on pallets and shall not be allowed on the ground. To provide protection from wind and rain, bagged and boxed materials shall be covered when not being actively used and prior to rain events. Broken boxes or bags shall be immediately contained or disposed of properly in accordance with WM-5 and WM-6.
- Stockpiles shall be protected in accordance with BMP WM-3, “Stockpile Management.”
- Minimize the material inventory stored on-site (e.g., only a few days supply).
- Have proper storage instructions posted at all times in an open and conspicuous location.
- Do not store hazardous chemicals, drums, or bagged materials directly on the ground. Dry items shall be placed on a pallet and covered. Liquids shall be placed in secondary containment and covered.
- Contain all fertilizers and other landscape materials when they are not actively being used.
- Stack erodible landscape material on pallets and cover stored landscaped materials when not being used or applied.
- Keep ample supply of appropriate spill clean up material near storage areas.

### ***Material Delivery Practices***

- Keep an accurate, up-to-date inventory of material delivered and stored on-site.
- Employees trained in emergency spill clean-up procedures shall be present when dangerous materials or liquid chemicals are unloaded.

### ***Spill Clean-up***

- Contain and clean up all liquid or dry spills or leaked material immediately and dispose of properly in accordance with WM-5 or WM-6.
- If residual materials are on the ground after construction is complete, properly remove and dispose any hazardous materials or contaminated soil in accordance with WM-5 and WM-6.
- Use BMP WM-4, “Spill Prevention and Control,” for cleanup procedures of spills of chemicals and/or hazardous materials.

- Maintenance and Inspection**
- Inspect all material delivery and storage areas weekly, and before and after every rainfall events. During extended rainfall events, inspect all material delivery and storage areas at least once every 24 hours.
  - Storage areas shall be kept clean, well organized, and equipped with ample clean-up supplies as appropriate for the materials being stored.
  - Perimeter controls, containment structures, covers, and liners shall be repaired or replaced as needed to maintain proper function.

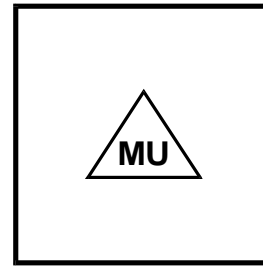
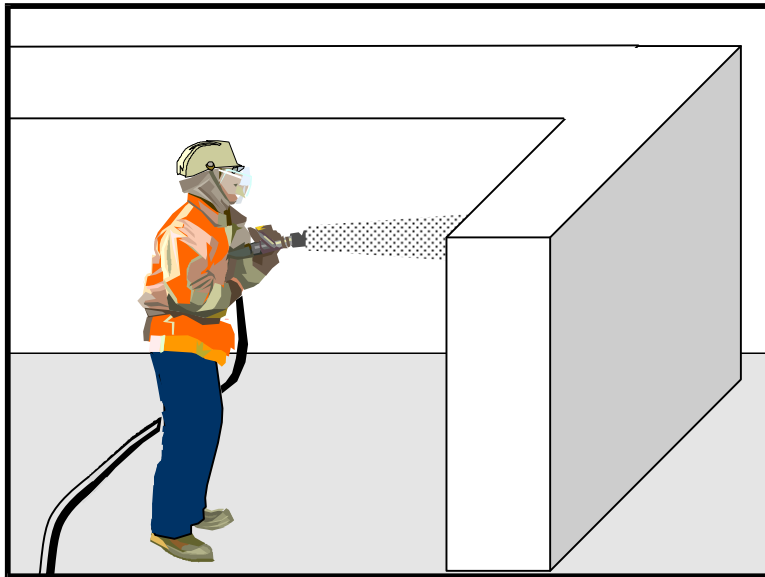

Standard Symbol

- BMP Objectives**
- Soil Stabilization
  - Sediment Control
  - Tracking Control
  - Wind Erosion Control
  - Non-Storm Water Management
  - Materials and Waste Management

**Definition and Purpose** These are procedures and practices for use of construction material in a manner that minimizes or eliminates the discharge of these materials to the ground, storm drain system or to watercourses.

**Appropriate Applications** This BMP applies to all construction sites. These procedures apply but are not limited to when the following materials are used or prepared on site:

- Hazardous chemicals such as:
  - Acids/lime,
  - glues,
  - adhesives,
  - paints/solvents, and
  - curing compounds.
- Soil stabilizers and binders.
- Fertilizers.
- Detergents.
- Plaster.
- Petroleum products such as fuel, oil, and grease.
- Asphalt and concrete components.
- Pesticides and herbicides.
- Other materials that may be detrimental if released to the environment.

- Limitations** ■ Safer alternative building and construction products may not be available or suitable in every instance.
- Standards and Specifications** ■ Material Safety Data Sheets (MSDS) shall be supplied to the Engineer for all materials stored or used on the project.
- Latex paint and paint cans, used brushes, rags, absorbent materials, and drop cloths, when thoroughly dry and are no longer hazardous, may be disposed of with other construction debris.
  - Do not remove the original product label, it contains important safety and disposal information. Use the entire product before disposing of the container.
  - Mix paint indoors, or in a containment area. Never clean paintbrushes or rinse paint containers into a street, gutter, storm drain or watercourse. Dispose of any paint thinners, residue and sludge(s), that cannot be recycled, as hazardous waste.
  - For water-based paint, clean brushes to the extent practical, and rinse to a drain leading to a sanitary sewer where permitted, or into a concrete washout pit. For oil-based paints, clean brushes to the extent practical and filter and reuse thinners and solvents.
  - Use recycled and less hazardous products when practical. Recycle residual paints, solvents, non-treated lumber, and other materials.
  - Use materials only where and when needed to complete the construction activity. Use safer alternative materials as much as possible. Reduce or eliminate use of hazardous materials on-site when practical.
  - Do not over-apply fertilizers and pesticides. Prepare only the amount needed. Strictly follow the recommended usage instructions. Apply surface dressings in smaller applications, as opposed to large applications, to allow time for it to work in and to avoid excess materials being carried off-site by runoff.
  - Discontinue the application of any erodible landscape material within 2 days before a forecasted rain event or during periods of precipitation.
  - Apply erodible landscape material at quantities and application rates according to manufacture recommendations or based on written specifications by knowledgeable and experienced field personnel.
  - Application of herbicides and pesticides shall be performed by a licensed applicator.
  - Contractors are required to complete the “Report of Chemical Spray Forms” when spraying herbicides and pesticides.
  - Keep an ample supply of spill clean up material near use areas. Train employees in spill clean up procedures.

- Avoid exposing applied materials to rainfall and runoff unless sufficient time has been allowed for them to dry.
- Maintenance and Inspections
- Inspect all material use areas weekly, and before and after every rainfall events. During extended rainfall events, inspect all material use areas at least once every 24 hours.

(This page left intentionally blank)

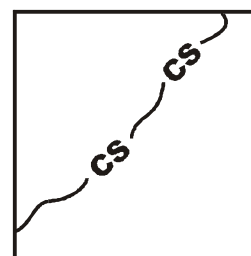

Standard Symbol

- BMP Objectives**

  - Soil Stabilization
  - Sediment Control
  - Tracking Control
  - Wind Erosion Control
  - Non-Storm Water Management
  - Materials and Waste Management

**Definition and Purpose** Stockpile management procedures and practices are designed to reduce or eliminate air and storm water pollution from stockpiles of soil, and paving materials such as portland cement concrete (PCC) rubble, asphalt concrete (AC), asphalt concrete rubble, aggregate base, aggregate subbase or pre-mixed aggregate, asphalt binder (so called “cold mix” asphalt), green waste and other materials and wastes.

**Appropriate Applications** Implemented in all projects that stockpile soil and other materials and wastes.

**Limitations** ■ None identified

- Standards and Specifications**
- Protection of stockpiles is a year-round requirement.
  - Locate stockpiles a minimum of 50 ft away from concentrated flows of storm water, drainage courses, and inlets.
  - Implement wind erosion control practices as appropriate on all stockpiled material. For specific information see BMP WE-1, “Wind Erosion Control”.
  - All stockpiles shall comply with AQMD Rule 403 requirements.
  - Contaminated soil shall not be stockpiled on the project site and be managed in accordance with BMP WM-7, “Contaminated Soil Management.”
  - Bagged materials should be placed on pallets and covered.
  - Do not stockpile pressure treated wood. Pressure treated wood shall be managed in accordance with the contact Special Provisions.

## ***Protection of Stockpiles not Actively Being Used***

- Cover and contain loose stockpiled construction materials that are not actively being used (i.e. soil, aggregate, base materials, green waste, etc.) at all times.

## **Protection of Active Stockpiles**

### ■ ***Soil stockpiles and waste stockpiles:***

- Soil stockpiles shall be covered and protected with a temporary perimeter sediment barrier.

### ■ ***Stockpiles of portland cement concrete rubble, asphalt concrete, asphalt concrete rubble, aggregate base, or aggregate subbase:***

- The stockpiles shall be covered and protected with a temporary perimeter sediment barrier.

### ■ ***Stockpiles of “cold mix”:***

- Cold mix stockpiles shall be placed on and covered with plastic or comparable material.

### ■ ***Stockpiles of green waste:***

- Green waste shall be covered and protected with a temporary perimeter sediment barrier.

Plastic materials shall be limited when more sustainable products exist. If plastic is used, materials more resistant to photo degradation shall be considered.

## **Inspection and Maintenance**

- Inspect all active and non-active stockpiles weekly, and before and after every rainfall events. During extended rainfall events, inspect all active and non-active stockpiles at least once every 24 hours.
- Repair and/or replace perimeter controls and covers as needed, or as directed by the Engineer, to keep them functioning properly. Sediment shall be removed when sediment accumulation reaches one-third (1/3) of the barrier height. Covers shall be repaired or replaced when they do not cover the entire stockpile or are no longer effective.



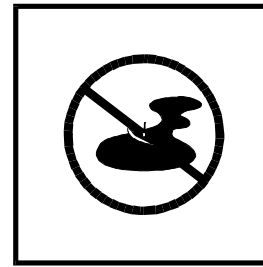
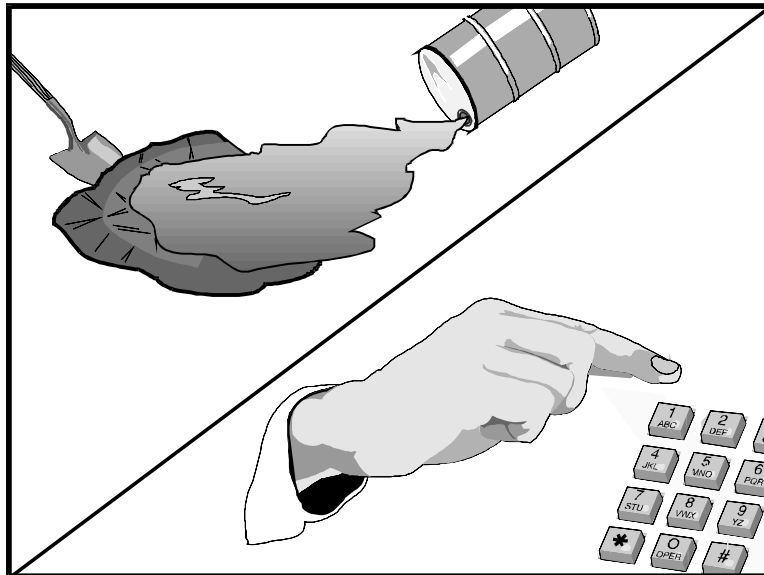

Standard Symbol

### BMP Objectives

- Soil Stabilization
- Sediment Control
- Tracking Control
- Wind Erosion Control
- Non-Storm Water Management
- Materials and Waste Management

**Definition and Purpose** These procedures and practices are implemented to prevent, control and clean-up spills in a manner that minimizes or prevents the discharge of spilled material to the permeable or impermeable ground surface, drainage system or watercourses.

**Appropriate Application** This best management practice (BMP) applies to all construction projects. Spill control procedures are implemented anytime liquids or dry materials or wastes (including chemicals, hazardous or non-hazardous substances) are stored or used onsite. Substances may include, but are not limited to:

- Soil stabilization products/binders.
- Dust Palliatives.
- Herbicides/Pesticides, Fertilizers
- Deicing/anti-icing chemicals.
- Sanitary wastes
- Fuels, Lubricants, Other petroleum distillates
- Paint solvents and thinners
- Vehicle fluids
- Asphalt and Portland Cement products

**Limitations** ■ Procedures and practices presented in this BMP are general. The Contractor shall identify appropriate practices for the specific materials or wastes used or stored on-site.

- Standards and Specifications**
- Spills of materials and wastes shall be contained and cleaned up immediately.
  - Spills identified during a rain event shall be covered and protected from storm water run-until they can be cleaned up.
  - Spills shall not be buried, or washed or cleaned up with water.
  - Water shall not be used to clean up spills. Dry methods such as rags and absorbents shall be used. Water used for decontaminating sampling equipment shall not be allowed to enter storm drains or watercourses and shall be collected.
  - All collected spill cleanup waste shall be disposed of in accordance with BMP WM-6, "Hazardous Waste Management."
  - Water overflow or minor water spillage shall be contained and shall not be allowed to discharge into drainage facilities or watercourses.
  - Proper storage, clean-up and spill reporting instruction for hazardous materials stored or used on the project site shall be posted at all times in an open, conspicuous and accessible location.
  - Waste storage areas shall be kept clean, well organized and equipped with ample clean-up supplies as appropriate for the materials being stored. Perimeter controls, containment structures, covers and liners shall be repaired or replaced as needed to maintain proper function.

### ***Education***

- Educate employees and subcontractors on what a "significant spill" is for each material they use, and what is the appropriate response for "significant" and "insignificant" spills.
- Educate employees and subcontractors on potential dangers to humans and the environment from spills and leaks.
- Hold regular meetings to discuss and reinforce appropriate disposal procedures (incorporate into regular safety meetings).
- Establish a continuing education program to train new employees.
- The Contractor shall oversee and enforce proper spill prevention and control measures and shall ensure appropriate personnel are assigned and trained for spill cleanup.

## ***Cleanup and Storage Procedures***

- Equipment and materials for cleanup of spills shall be available on site and spills and leaks shall be cleaned up immediately and disposed of properly.
- Sewage pipeline breaks or spills shall be handled in accordance with the contract special provisions, if applicable. The required plan for sewage spills shall be referenced and described in Section 500.4.6 of the SWPPP, if applicable.
- Minor Spills
  - Minor spills typically involve small quantities of oil, gasoline, paint, etc., which can be controlled by the first responder at the discovery of the spill.
  - Use absorbent materials on small spills. Water shall not be used to clean up spills. Do not bury the spill or spilled materials.
  - Remove the absorbent materials promptly and dispose of properly.
  - The practice commonly followed for a minor spill is:
    - Contain the spread of the spill.
    - Recover spilled materials.
    - Clean the contaminated area and/or properly dispose of contaminated materials.
- Semi-Significant Spills
  - Semi-significant spills still can be controlled by the first responder along with the aid of other personnel such as laborers and the foreman, etc. This response may require the cessation of all other activities.
  - Clean up spills immediately:
    - Notify the project foreman immediately. The foreman shall notify the Engineer.
    - Contain spread of the spill.
    - If the spill occurs on paved or impermeable surfaces, clean up using "dry" methods (absorbent materials, cat litter and/or rags). Contain the spill by encircling with absorbent materials and do not let the spill spread widely.
    - If the spill occurs in dirt areas, immediately contain the spill by constructing an earthen dike. Dig up and properly dispose of contaminated soil.
    - If the spill occurs during rain, cover spill with tarps or other material to prevent contaminating runoff.

## ■ Significant/Hazardous Spills

- For significant or hazardous spills that cannot be controlled by personnel in the immediate vicinity, the following steps shall be taken:
- Notify the Engineer immediately and follow up with a written report.
- Notify the local emergency response by dialing 911. In addition to 911, the contractor will notify the proper county officials. It is the contractor's responsibility to have all emergency phone numbers at the construction site. The Los Angeles County Fire Department Health Hazardous Material Division should be called at (323)890-4317 or after hours Call: 911 or (323)881-2455 (Health Haz Mat).
- For spills of federal reportable quantities, in conformance with the requirements in 40 CFR parts 117.3 and 302.4, the contractor shall notify the National Response Center at (800) 424-8802.
- The services of a spills contractor or a Haz-Mat team shall be obtained immediately. Construction personnel shall not attempt to clean up the spill until the appropriate and qualified staff has arrived at the job site.
- Other agencies which may need to be consulted include, but are not limited to, the Coast Guard, the Highway Patrol, the City/County Police Department, Department of Toxic Substances, California Division of Oil and Gas, Cal/OSHA, RWQCB, etc.

## ***Disposal Procedures***

- Proper disposal is disposal offsite in accordance with all applicable laws and regulations.
- Used clean up materials, contaminated materials, and recovered spill material that is no longer suitable for the intended purpose shall be stored and disposed of in accordance with WM-6, "Hazardous Waste Management" BMPs.
- Waste that is not hazardous and is not defined as waste that requires special handling under California Code of Regulations, Title 22 Division 4.5, Title 23, Division 3, Chapter 3, and Title 27, Division 2, Subdivision 1 shall be disposed of in accordance WM-5 Solid Waste Management.

## Maintenance and Inspection

- Inspect the project site for spills daily and document weekly, and before and after every rainfall events. During extended rainfall events, inspect project site for spills at least once every 24 hours.
- Verify that spill control clean-up materials are located near material storage, unloading, and use areas.
- Update spill prevention and control plan and stock appropriate clean-up materials whenever changes occur in the types of chemicals used or stored onsite.

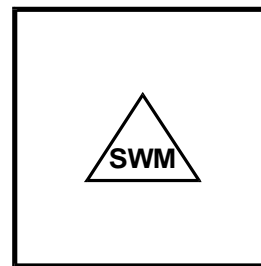
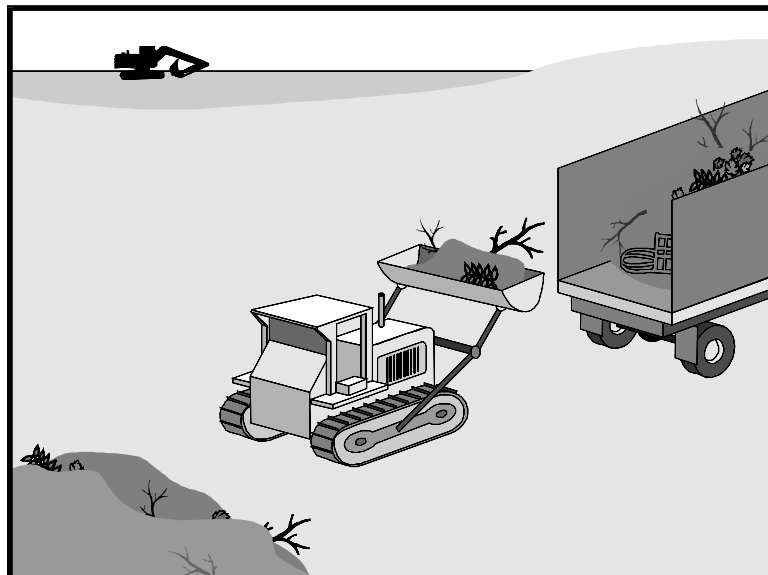

Standard Symbol

### BMP Objectives

- Soil Stabilization
- Sediment Control
- Tracking Control
- Wind Erosion Control
- Non-Storm Water Management
- Materials and Waste Management

**Definition and Purpose** Solid waste management procedures and practices are designed to minimize or eliminate the discharge of pollutants offsite, to the ground, drainage systems or watercourses.

**Appropriate Applications** Solid waste management procedures and practices are implemented on all construction sites that generate solid wastes.

Solid wastes include but are not limited to:

- Construction wastes including brick, dry mortar, timber, steel and metal scraps, sawdust, pipe and electrical cuttings, inert equipment parts, styrofoam and other materials used to transport and package construction materials.
- Planting wastes, including vegetative material, plant containers, and packaging materials.
- Litter and debris including food containers, beverage cans, coffee cups, paper bags, plastic wrappers, and smoking materials, including litter generated by the public and other contractors.

**Limitations** ■ Solid waste that requires special handling and disposal because of a potential hazard to human health, the environment, or water quality shall be handled and disposed of in accordance with WM-6.

**Standards and Specifications** **Education**

- The Contractor shall oversee and enforce proper solid waste procedures and practices.
- Educate employees and subcontractors on solid waste storage and disposal procedures. Hold regular meetings to discuss and reinforce disposal procedures (incorporate into regular safety meetings).

- Require that employees and subcontractors follow solid waste handling and storage procedures.
- Prohibit littering by employees, subcontractors, and visitors.
- Wherever possible, minimize production of solid waste materials.

### ***Collection, Storage, and Disposal***

- Prevent discharges from waste disposal containers to the ground, offsite or storm water drainage system or receiving water.
- Litter and debris shall be removed from drainage grates, trash racks, and ditch lines immediately.
- The contractor shall provide covered and watertight dumpsters of sufficient size and numbers to contain the solid waste generated on the construction site including waste generated by the public. Cover waste disposal containers at all times.
- Trash containers/dumpsters shall be provided in the Contractor's yard, field trailer areas, and at locations where workers congregate for lunch and break periods or where directed by the Engineer. Additional containers and more frequent pickup and removal are required during the demolition phase of construction.
- Trash containers/dumpsters shall be empty once every two weeks. Full trash containers/dumpsters shall be empty within two days of being full. The contents of the containers/dumpsters and all solid waste shall be disposed of outside the right-of-way in conformance with all applicable laws and regulations.
- Litter stored in containers shall be handled and disposed of by licensed disposal contractors.
- Solid waste disposal haulers and facilities shall be approved by the Engineer. The Contractor shall be responsible for signing any manifests for solid waste disposal.
- Solid waste containers shall be located at least 50 ft from drainage facilities and watercourses and shall not be located in areas susceptible to flooding or ponding.
- Waste container washout on the construction site is not allowed.
- Additional containers and more frequent pickup and removal are required during the demolition phase of construction.
- Segregate potentially hazardous waste from non-hazardous construction site waste.

## Maintenance and Inspection

- Liquid wastes (e.g., used oils, solvents, and paints) and chemicals (e.g., acids, pesticides, additives, curing compounds) and solid waste that is hazardous shall not be disposed of in containers designated for solid waste. See BMP WM-6, “Hazardous Waste Management” for proper disposal procedures.
- Salvage or recycle vegetation debris, packaging and/or surplus building materials when practical. Wood pallets, cardboard boxes, and construction scraps can be recycled.
- Inspect the project site for solid waste management daily and document weekly, and before and after every rainfall events. During extended rainfall events, inspect project site for solid waste management at least once every 24 hours.
- Inspect solid waste disposal facilities to identify any waste that should be handled and disposed of under WM-6 Hazardous Waste Management. Typically, inspect for used oily rags, used absorbent, used oil containers, and other wastes that require special handling and disposal.



(This page left intentionally blank)



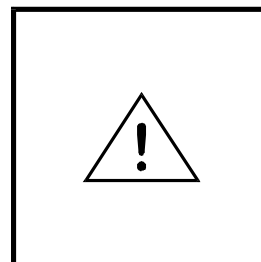
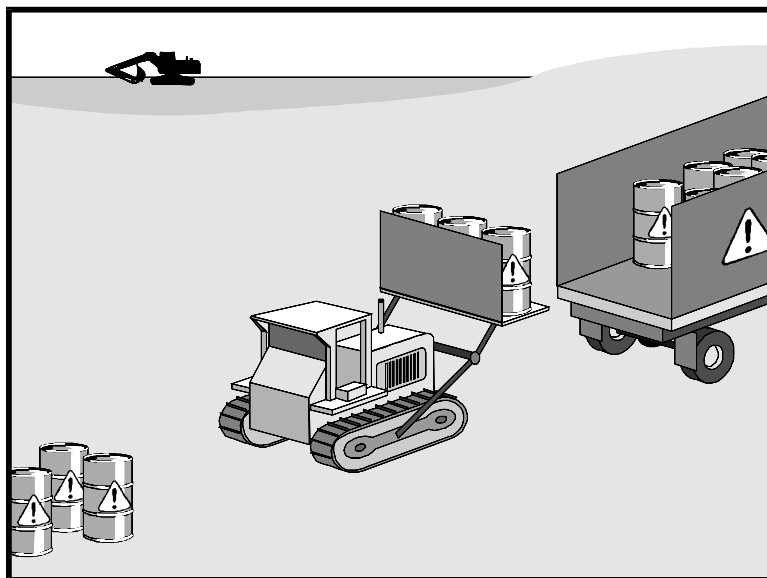

Standard Symbol

**BMP Objectives**

- Soil Stabilization
- Sediment Control
- Tracking Control
- Wind Erosion Control
- Non-Storm Water Management
- Materials and Waste Management

**Definition and Purpose** These are procedures and practices to minimize or eliminate the discharge of pollutants from contractor generated waste or waste illegally dumped on site by others, that is hazardous waste, or waste that is otherwise not allowed to be disposed of as solid waste, to the ground, storm drain systems or to watercourses.

- Appropriate Applications**
- This best management practice (BMP) applies to all construction sites. This applies to hazardous waste, non-hazardous waste, designated waste and any other waste that requires special disposal practices due to a potential threat to human health, the environment, or water quality, or as identified by the Engineer. It can be solid, liquid or gaseous waste that is regulated and requires special handling and disposal.
  - Hazardous waste management applies to median and shoulder soils of roadways that have been contaminated by aerially deposited lead (ADL). Refer to contract Special Provisions.
  - Hazardous waste management practices are implemented on construction sites that generate waste from but not limited to:
    - Petroleum Products,
    - Asphalt Products,
    - Concrete Curing Compounds,
    - Herbicides/Pesticides,
    - Acids/bases,
    - Paints/Stains,
    - Solvents,
    - Wood Preservatives,

- Any materials deemed a hazardous waste in California Code of Regulations, Title 23, Division 3, Chapter 15, Title 22 Division 4.5, or listed in 40 CFR Parts 110, 117, 261, or 302, or
- Any materials deemed designated waste or non-hazardous waste in California Code of Regulations, Title 27 Division 2, Subdivision 1.

- Limitations**
- This BMP does not relieve the Contractor from responsibility for compliance with federal, state, and local laws regarding storage, handling, transportation, and disposal of hazardous wastes.
  - This BMP does not cover waste addressed specifically by the contract Special Provisions.

## Standards and Specifications

### ***Education***

- Educate employees and subcontractors on proper hazardous waste storage and disposal procedures.
- Educate employees and subcontractors on safety procedures and potential dangers to humans and the environment from hazardous wastes.
- Educate employees and subcontractors in identification of hazardous and solid waste.
- Hold regular meetings to discuss and reinforce hazardous waste management procedures (incorporate into regular safety meetings).
- The Contractor's Qualified SWPPP Practitioner (QSP) or BMP manager for projects without SWPPPs shall oversee and enforce proper hazardous waste management procedures and practices.
- Make sure that hazardous waste is collected, removed, and disposed of only at authorized disposal areas.

### ***Storage Procedures***

- All hazardous wastes shall be stored in a secured area and in approved, sealed, and leak-proof containers with sealed lids constructed of a suitable material and shall be labeled as required by Title 22 CCR, Division 4.5 and 49 CFR Parts 172,173, 178, and 179.
- All hazardous waste shall be stored, transported, and disposed as required in Title 22 CCR, Division 4.5 and 49 CFR 261-263.
- Waste containers shall be stored in temporary containment facilities that shall comply with the following requirements:
  - Temporary containment facility shall provide a spill containment volume able to contain precipitation from a 24-hour, 25 year storm event, plus the greater of 10% of the aggregate volume of all containers or 100% of the capacity of the largest container within its boundary, whichever is greater.



- Temporary containment facility shall be impervious to the materials stored there for a minimum contact time of 72 hours.
- Temporary containment facilities shall be covered and maintained free of accumulated rainwater and spills. In the event of spills or leaks accumulated rainwater and spills shall be immediately placed into drums after each rainfall. These liquids shall be handled as a hazardous waste unless testing determines them to be non-hazardous. Non-hazardous liquids shall be sent to an approved disposal site.
- Sufficient separation shall be provided between stored containers to allow for spill cleanup and emergency response access.
- Incompatible materials, such as chlorine and ammonia, shall not be stored in the same temporary containment facility.
- Temporary containment facilities shall be covered at all times. Covered facilities may include use of plastic tarps for small facilities or constructed roofs with overhangs. A storage facility having a solid cover and sides is preferred to a temporary tarp. Storage facilities shall be equipped with adequate ventilation.
- Drums shall not be overfilled and wastes shall not be mixed.
- Containers of dry waste shall be stored on pallets.
- Paint brushes and equipment for water and oil based paints shall be cleaned within a contained area and shall not be allowed to contaminate site soils, watercourses or drainage systems. Waste paints, thinners, solvents, residues, and sludges that cannot be recycled or reused shall be disposed of as hazardous waste. When thoroughly dry, latex paint and paint cans, used brushes, rags, absorbent materials, and drop cloths shall be disposed of as solid waste.
- Ensure that hazardous waste collection containers and spill kits are available at all hazardous waste storage areas.
- Designate hazardous waste storage areas on site away from storm drains or watercourses and away from moving vehicles and equipment to prevent accidental spills. All hazardous wastes shall be protected from traffic and equipment.
- Minimize production or generation of hazardous materials and hazardous waste on the construction site.
- Use containment berms in fueling and maintenance areas and where the potential for spills is high.
- Segregate potentially hazardous waste from non-hazardous construction site debris.

- Keep liquid or semi-liquid hazardous waste in appropriate containers (closed drums or similar) and under cover.
- Clearly label all hazardous waste containers with the waste being stored and the date of accumulation.
- Clean up spills of waste immediately.
- Do not mix different types wastes. For example, do not mix solids and liquids and do not mix hazardous and non-hazardous, nor designated and non-hazardous.

### ***Disposal Procedures***

- These disposal procedures apply to waste disposal unless specifically stated otherwise in the contract Special Provisions.
- If directed by the Engineer, the Contractor shall collect an appropriate number of samples of waste generated and shall have the sample analyzed by a Department of Health Services (DHS) certified laboratory in order to meet waste profiling requirements of the disposal facility.
- The Contractor shall complete all required waste profile forms. The “Generator” of the hazardous waste shall be identified by the Engineer. If the spill/leak of hazardous waste is caused by the Contractor or Contractor’s operations, the Contractor shall be identified as the “Generator” of the hazardous waste.
- A copy of a completed and typed draft Hazardous Waste Manifest for the transportation of hazardous waste, including the correct EPA ID Number, shall be submitted to the Engineer for approval prior to transporting the hazardous waste off-site. The Engineer shall provide the EPA ID Number. If the Contractor is identified as the Generator, then the Contractor shall obtain the EPA ID Number. Hazardous waste shall not be transported off-site unless the Hazardous Waste Manifest has been signed by the Generator.
- A copy of a completed and typed draft Non-Hazardous Waste Manifest for the transportation of non-hazardous waste shall be submitted to the Engineer for approval prior to transporting the non-hazardous waste off-site. Non-Hazardous waste shall not be transported off-site unless the Non-Hazardous Waste Manifest has been signed by the Generator.
- Waste shall be transported by a licensed hazardous waste transporter to an authorized and licensed disposal facility or recycling facility.
- Hazardous waste as defined by California Code of Regulations, Title 22 CCR, Division 4.5 and Title 23, Division 3, Chapter 15 or as determined by the Engineer shall not be stored on site unless covered by the contract Special Provisions.

## Maintenance and Inspection

- Hazardous waste, non-hazardous waste, designated waste and other waste that presents a potential threat to human health, the environment or water quality shall be disposed in accordance with all applicable laws and regulations including but not limited to California Code of Regulations, Title 22 Division 4.5, Title 23, Division 3, Chapter 3, and Title 27, Division 2, Subdivision 1.
- Make sure that toxic liquid wastes (e.g., used oils, solvents, and paints), chemicals (e.g., acids, pesticides, additives, curing compounds), and any other wastes that have special handling and disposal requirements under California Code of Regulations, Title 22 Division 4.5, Title 23, Division 3, Chapter 3, and Title 27, Division 2, Subdivision 1 are not disposed of in dumpsters designated for solid waste or construction debris.
- Dispose of rainwater accumulated in secondary containment as hazardous waste.
- The Contractor's Site-Specific Health and Safety Officer (SHSO) or Safety Office (based on contract Special Provisions) shall monitor on-site hazardous waste storage and disposal procedures.
- Inspect the project site for non-hazardous and hazardous waste weekly, and before and after every rainfall events. During extended rainfall events, inspect project site for non-hazardous and hazardous waste at least once every 24 hours.
- Waste storage areas shall be kept clean, well organized, and equipped with ample clean-up supplies as appropriate for the materials being stored.
- Storage areas shall be inspected in conformance with the contract Special Provisions and the SWPPP.
- Perimeter controls, containment structures, covers, and liners shall be repaired or replaced as needed to maintain proper function.

(This page left intentionally blank)

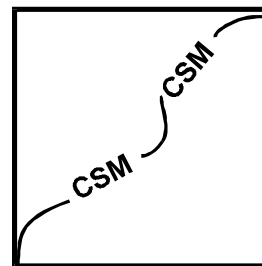
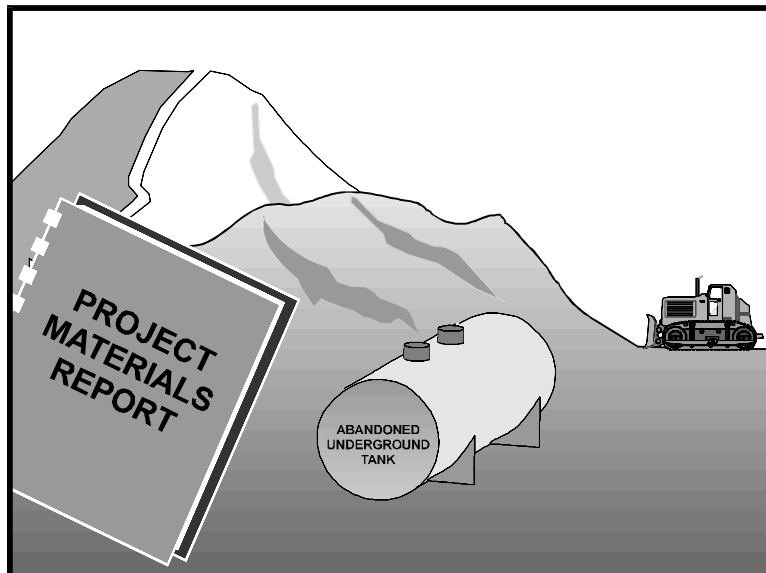

Standard Symbol

- BMP Objectives**
- Soil Stabilization
  - Sediment Control
  - Tracking Control
  - Wind Erosion Control
  - Non-Storm Water Management
  - Materials and Waste Management

**Definition and Purpose** These are procedures and practices to minimize or eliminate the discharges of pollutants to the drainage system or to watercourses from contaminated soil.

**Appropriate Applications**

- Contaminated soil management is implemented on construction projects in highly urbanized or industrial areas where soil contamination may have occurred due to spills, illicit discharges, and leaks from underground oil pipelines and storage tanks.

**Limitations**

- The procedures and practices presented in this best management practice (BMP) are general. The contractor shall identify appropriate practices and procedures for the specific contaminants known to exist or discovered on site.

**Standards and Specifications**

- Contaminated soils are often identified during project planning and development with known locations identified in the contract Special Provisions.

- If contaminated soils are encountered on the project site and are not identified in the contract Special Provisions. The Engineer shall solely characterize the extent, volume, and type of contaminated soil.

- All soil sampling will be conducted by the Engineer.

**Education**

- The Contractor shall comply with the Agency-approved Site-Specific Health and Safety Plan (refer to contract Special Provisions).

- Prior to performing any excavation work at the locations containing material classified as hazardous, employees and subcontractors shall complete a safety training program which meets 29 CFR 1910.120 and 8 CCR 5192 covering the potential hazards as identified.

- Educate employees and subcontractors in identification of contaminated soil.
  - Detected or undetected spills and leaks.
  - Acid or alkaline solutions from exposed soil or rock formations high in acid or alkaline forming elements.
  - Look for contaminated soil as evidenced by discoloration, odors, differences in soil properties, abandoned underground tanks or pipes, or buried debris.

### ***Handling Procedures for Contaminated Soils***

- To minimize on-site storage, contaminated soil shall be disposed of properly in accordance with all applicable regulations. All hazardous waste storage will comply with the requirements in Title 22, CCR, Sections 6626.250 to 66265.260.
- Contaminated soils or hazardous material shall not be stockpiled on the project site.
- Contaminated material and hazardous material on exteriors of transport vehicles shall be removed and placed either into the current transport vehicle or the excavation prior to the vehicle leaving the exclusion zone.
- Procure all permits and licenses, pay all charges and fees, and give all notices necessary and incident to the due and lawful prosecution of the work, including registration for transporting vehicles carrying the contaminated material and the hazardous material.
- Collect water from decontamination procedures and treat and/or dispose of it at an appropriate disposal site.
- Collect non-reusable protective equipment, once used by any personnel, and dispose of at an appropriate disposal site.
- Install temporary security fence to surround and secure the exclusion zone. Remove fencing when no longer needed.
- Excavation, transport, and disposal of contaminated material and hazardous material/waste shall be in accordance with the rules and regulations of the following agencies (the specifications of these agencies supersede the procedures outlined in this BMP):
  - United States Department of Transportation (USDOT).
  - United States Environmental Protection Agency (USEPA).
  - California Environmental Protection Agency (CAL-EPA).
  - California Division of Occupation Safety and Health Administration (CAL-OSHA).
  - Local regulatory agencies.



## ***Procedures for Underground Storage Tank Removals***

- Prior to commencing tank removal operations, obtain the required underground storage tank removal permits and approval from the federal, state, and local agencies, which have jurisdiction over such work.
- Arrange to have tested, as directed by the Engineer, any liquid or sludge found in the underground tank prior to its removal to determine if it contains hazardous substances.
- Following the tank removal, take soil samples beneath the excavated tank and perform analysis as required by the local agency representative(s).
- The underground storage tank, any liquid and/or sludge found within the tank, and all contaminated substances and hazardous substances removed during the tank removal shall be transported to disposal facilities permitted to accept such waste.

## ***Water Control***

- Take all necessary precautions and preventive measures to prevent the flow of water, including ground water, from mixing with hazardous substances or underground storage tank excavations. Such preventative measures may consist of, but are not limited to: berms, cofferdams, grout curtains, freeze walls, and seal course concrete or any combination thereof.
- If water does enter an excavation and becomes contaminated, such water, when necessary to proceed with the work, shall be transported off-site and disposed at a recycling or disposal facility approved by the Engineer.

## **Maintenance and Inspection**

- The Contractor's Site-Specific Health and Safety Officer (SHSO) or Safety Office (based on contract Special Provisions) shall monitor contaminated soil excavation and disposal procedures.
- Inspect the areas of known contaminated soil weekly, and before and after every rainfall events. During extended rainfall events, inspect areas of known contaminated soil at least once every 24 hours.
- Confirm that areas of known contaminated soil are secure and not being tracked or impacting water quality.

(This page left intentionally blank)

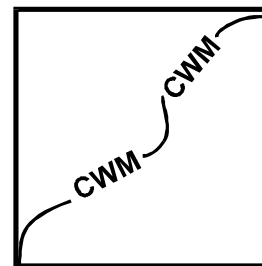
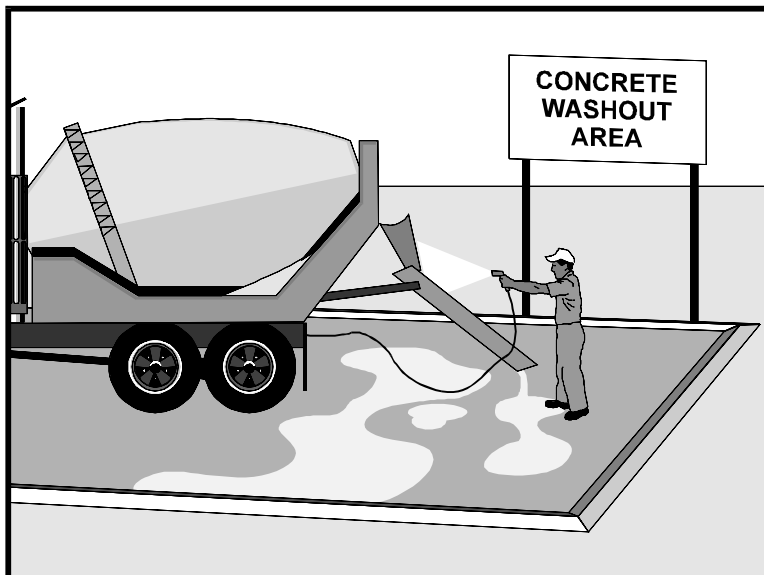

Standard Symbol

<b>BMP Objectives</b>	
<input type="radio"/>	Soil Stabilization
<input type="radio"/>	Sediment Control
<input type="radio"/>	Tracking Control
<input type="radio"/>	Wind Erosion Control
<input checked="" type="radio"/>	Non-Storm Water Management
<input checked="" type="radio"/>	Materials and Waste Management

**Definition and Purpose** These are procedures and practices that are designed to minimize or eliminate the discharge of concrete waste and similar materials to the ground, storm drain systems or watercourses.

- Appropriate Applications**
- Concrete waste management procedures and practices are implemented on construction projects where concrete is used as a construction material or where concrete dust and debris result from demolition activities.
  - Where slurries containing Portland cement concrete (PCC) or asphalt concrete (AC) are generated, such as from sawcutting, coring, grinding, grooving, and hydro-concrete demolition.
  - Where concrete trucks and equipment are washed on site, when approved by the Engineer. Refer to NS-8, "Vehicle and Equipment Cleaning."
  - Where grout and mortar-mixing stations are used.

**Limitations** ■ None identified.

- Standards and Specifications**
- Concrete washout areas and other washout areas shall not discharge or leak onto the underlying soil or to the surrounding areas.
  - Watertight concrete washout bins are recommended.

### **Education**

- Educate all employees, subcontractors, and suppliers on the concrete waste management requirements described herein.
- The Contractor's Qualified SWPPP Practitioner (QSP) or BMP Manager (based on the contract Special Provisions) shall oversee and enforce concrete waste management procedures.

## ***Concrete Demolition Wastes***

- Stockpile concrete demolition wastes in accordance with BMP WM-3, “Stockpile Management.”
- Disposal of hardened PCC and AC waste outside the site to an appropriate facility (in accordance with WM-5) or as directed by Engineer if allowed to incorporate onsite.

## ***Concrete Slurry Waste Management and Disposal***

- PCC and AC waste shall not be allowed to discharge to the ground or enter storm drainage systems or watercourses.
- A sign shall be installed adjacent to each temporary concrete washout facility to inform concrete equipment operators to utilize the proper facilities as shown on Page 6.
- Residue from saw cutting, coring and grinding operations shall be picked up by means of a vacuum device. Residue shall not be allowed to flow across the pavement and shall not be left on the surface of the pavement. See also BMP NS-3, “Paving and Grinding Operations.”
- Vacuumed slurry residue shall be disposed of in accordance with BMP WM-5, “Solid Waste Management.” Slurry residue shall be disposed of immediately offsite or temporarily stored in a facility as described in “Onsite Temporary Concrete Washout Facility, Concrete Transit Truck Washout Procedures” below), or within an impermeable containment vessel or bin approved by the Engineer.

## ***Onsite Temporary Concrete Washout Facility, Concrete Transit Truck Washout Procedures***

- Temporary concrete washout facilities shall be located a minimum of 50 ft from storm drain inlets, open drainage facilities, and watercourses, unless determined infeasible by the Engineer. Each facility shall be located away from construction traffic or access areas to prevent disturbance or tracking.
- A sign shall be installed adjacent to each washout facility to inform concrete equipment operators to utilize the proper facilities. The sign shall be installed as shown on page 6.
- Temporary concrete washout facilities shall be constructed above or below grade, or placed in watertight bins or containers. Temporary concrete washout facilities shall be constructed and maintained in sufficient quantity and size to contain all liquid and concrete waste generated.
- Wash concrete from mixer chutes into approved concrete washout facility. Perform washout of concrete mixers, delivery trucks, and other delivery systems in designated areas only.

- Pump excess concrete in concrete pump bin back into concrete mixer truck.
- Concrete washout from concrete pumper bins can be washed into concrete pumper trucks and discharged into designated washout area or properly disposed offsite.
- Once concrete wastes are washed into the designated area and allowed to harden, the concrete shall be broken up, removed, and disposed of in conformance with applicable federal, state and local regulations (WM-5).
- Washout facilities will be covered 24 hours prior to a 50% or more chance of rain. If not covered prior to rain, washouts shall be covered during rain event. No water will be allowed to overflow from washout and any accumulated rain water will be handled and disposed of as washout water.

### ***Temporary Concrete Washout Facility Type “Above Grade”***

- Temporary concrete washout facility Type “Above Grade” shall be constructed as shown on Page 6 or 7, with a minimum length and minimum width of 10 ft, but with sufficient quantity and volume to contain all liquid and concrete waste generated by washout operations. .
- Straw bales, wood stakes, and sandbag materials shall conform to the provisions in BMP SC-9, "Straw Bale Barrier" and BMP SC-8, “Sandbag Barrier.”
- Plastic lining material shall be a minimum of 10-mil polyethylene sheeting and shall be free of holes, tears or other defects that compromise the impermeability of the material. Liner seams shall be installed in accordance with manufacturers’ recommendations. No seams in the plastic are allowed at the bottom of the washout.

### ***Temporary Concrete Washout Facility (Type Below Grade)***

- Temporary concrete washout facility Type “Below Grade” shall be constructed as shown on page 7, with a recommended minimum length and minimum width of 10 ft. The quantity and volume shall be sufficient to contain all liquid and concrete waste generated by washout operations. The length and width of a facility may be increased, at the Contractor’s expense, upon approval of the Engineer. Lath and flagging shall be commercial type.
- Plastic lining material shall be a minimum of 10-mil polyethylene sheeting and shall be free of holes, tears or other defects that compromise the impermeability of the material. Liner seams shall be installed in accordance with manufacturers’ recommendations. No seams in the plastic material are allowed at the bottom of the washout.
- The soil base shall be prepared free of rocks or other debris that may cause tears or holes in the plastic lining material.

## ***Removal of Temporary Concrete Washout Facilities***

### **Maintenance and Inspection**

- When temporary concrete washout facilities are no longer required for the work and as washouts are filled, as determined by the Engineer, the hardened concrete shall be removed and disposed of in conformance with applicable federal, state and local regulations. Disposal of PCC dried residues, slurries or liquid waste shall be disposed of in conformance with all applicable laws and regulations. Materials used to construct temporary concrete washout facilities shall become the property of the Contractor, shall be removed from the site of the work, and shall be disposed of in conformance with all applicable laws and regulations.
- Holes, depressions or other ground disturbance caused by the removal of the temporary concrete washout facilities shall be backfilled and repaired.
- Inspect temporary concrete washout facilities weekly, and before and after every rainfall events. During extended rainfall events, inspect temporary concrete washout facilities at least once every 24 hours.
- Temporary concrete washout facilities shall be maintained to provide adequate holding capacity with a minimum freeboard of 4 inches for above grade facilities and 12 inches for below grade facilities. Maintaining temporary concrete washout facilities shall include removing and disposing of hardened concrete and returning the facilities to a functional condition. Hardened concrete materials shall be removed and disposed of in conformance with applicable federal, state and local regulations.
- Existing facilities must be cleaned, or new facilities must be constructed and ready for use once the washout is 75% full.
- Temporary concrete washout facilities shall be inspected for damage (i.e. tears in polyethylene liner, missing sandbags, etc.). Damaged facilities shall be repaired immediately.

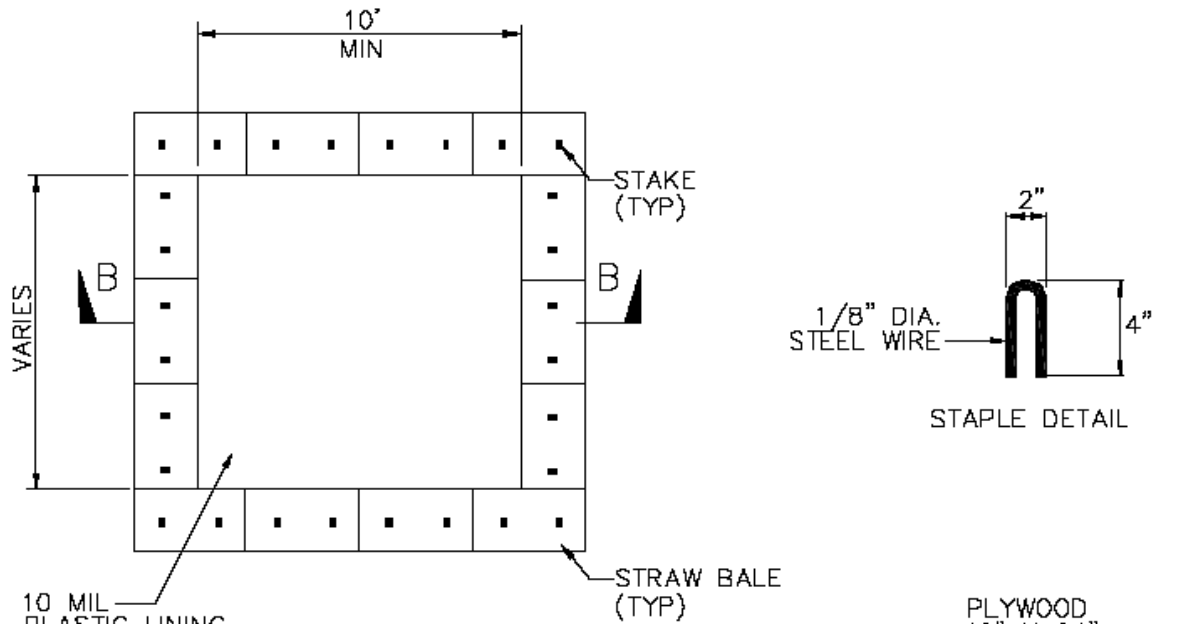

**PLAN**  
NOT TO SCALE  
TYPE "ABOVE GRADE"  
WITH STRAW BALES

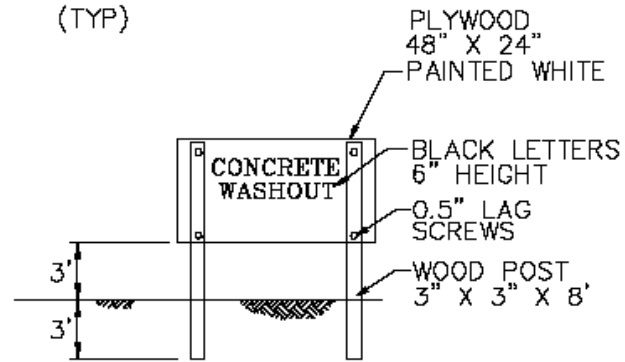
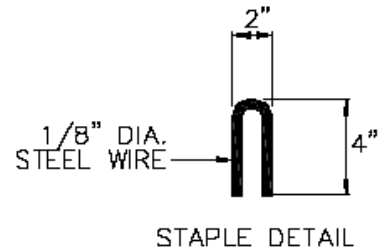

**CONCRETE WASHOUT SIGN DETAIL**  
(OR EQUIVALENT)

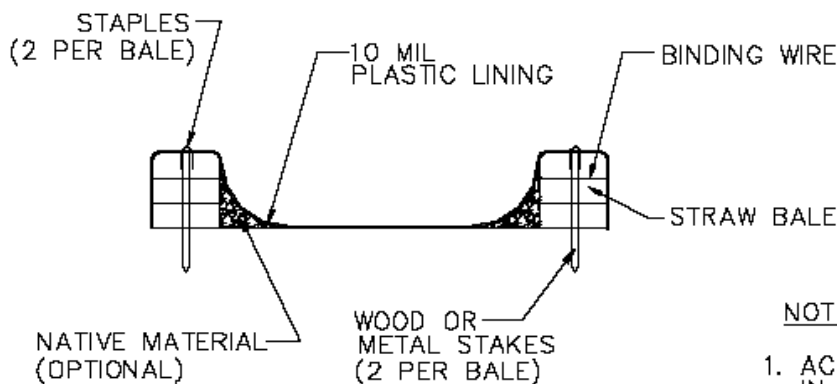

**SECTION B-B**  
NOT TO SCALE

NOTES

1. ACTUAL LAYOUT DETERMINED IN FIELD.
2. THE CONCRETE WASHOUT SIGN SHALL BE INSTALLED WITHIN 30 FT. OF THE TEMPORARY CONCRETE WASHOUT FACILITY.

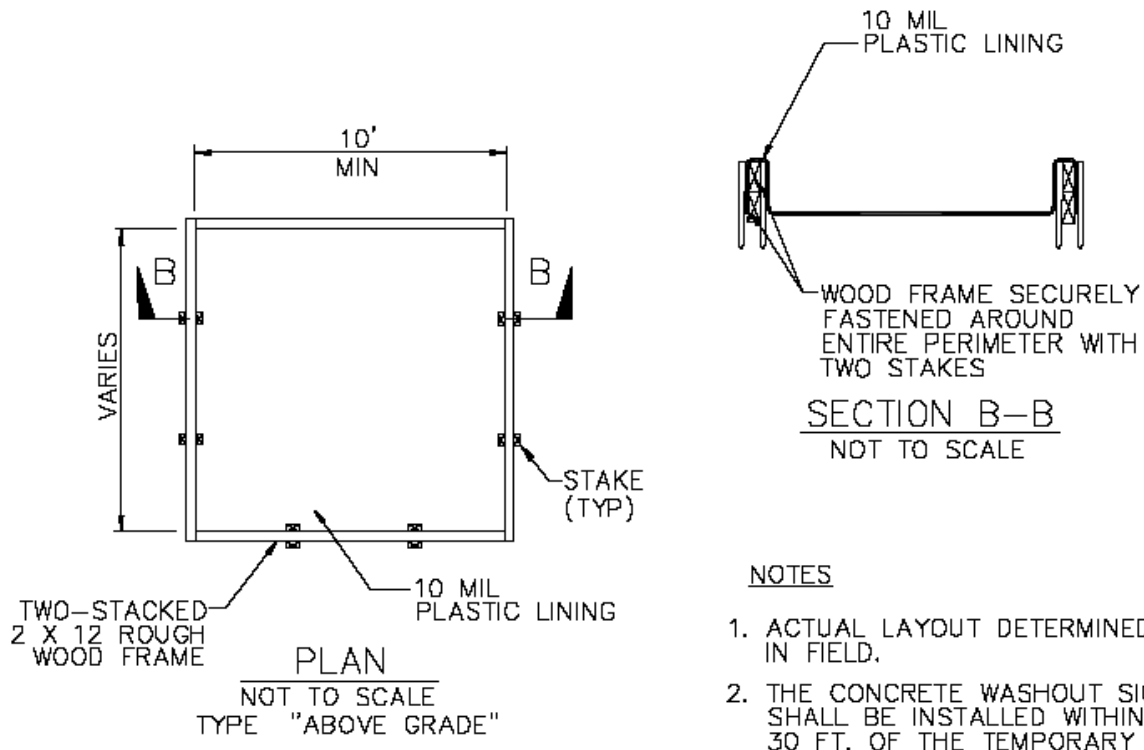
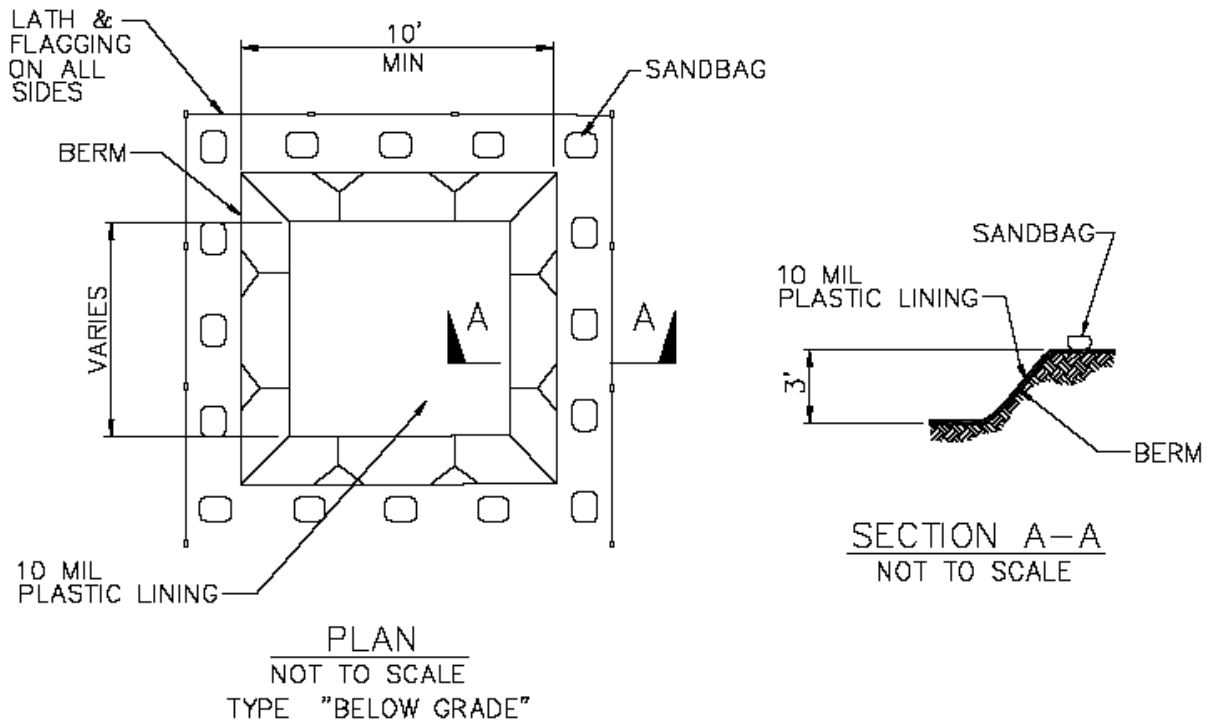

- NOTES**
1. ACTUAL LAYOUT DETERMINED IN FIELD.
  2. THE CONCRETE WASHOUT SIGN SHALL BE INSTALLED WITHIN 30 FT. OF THE TEMPORARY CONCRETE WASHOUT FACILITY.



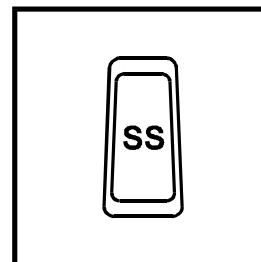
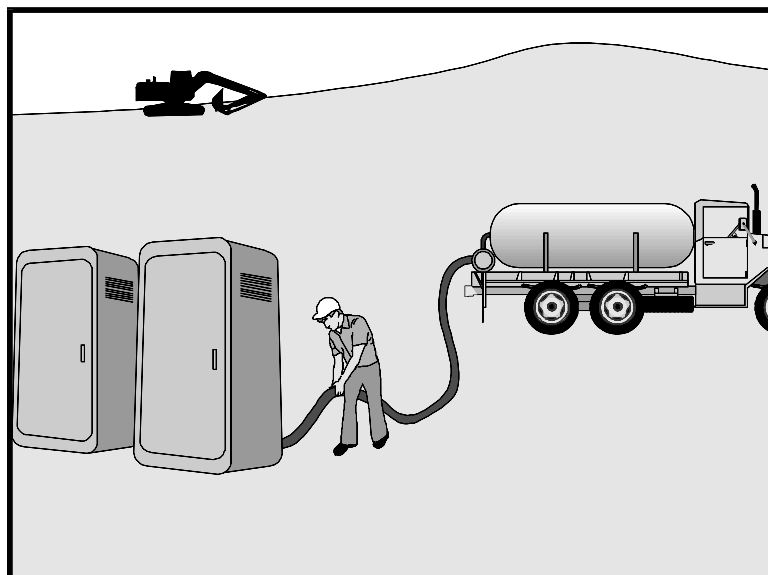

Standard Symbol

### BMP Objectives

- Soil Stabilization
- Sediment Control
- Tracking Control
- Wind Erosion Control
- Non-Storm Water Management
- Materials and Waste Management

**Definition and Purpose** Procedures and practices to minimize or eliminate the discharge of construction site sanitary/septic waste materials to the storm drain system or to watercourses.

**Appropriate Applications** Sanitary/septic waste management practices are implemented on all construction sites that use temporary or portable sanitary/septic waste systems.

**Limitations** ■ None identified.

### Standards and Specifications

#### **Education**

- Educate employees, subcontractors, and suppliers on sanitary/septic waste storage and disposal procedures.
- Educate employees, subcontractors, and suppliers of potential dangers to humans and the environment from sanitary/septic wastes.
- Hold regular meetings to discuss and reinforce disposal procedures (incorporate into regular safety meetings).

#### **Storage and Disposal Procedures**

- Ensure the containment of sanitation facilities (e.g., portable toilets) to prevent discharges of pollutants to the ground surface, storm water drainage system or receiving water.
- Clean or replace sanitation facilities and inspect them regularly for leaks and spills.
- Temporary sanitary facilities shall be located away from drainage facilities, watercourses, and from traffic circulation. When subjected to high winds or risk, temporary sanitary facilities shall be secured to prevent overturning.

- Wastewater shall not be discharged or buried on the construction site.
- Sanitary and septic systems that discharge directly into sanitary sewer systems, where permissible, shall comply with the local health agency, city, county, and sewer district requirements.
- Properly connect temporary sanitary facilities that discharge to the sanitary sewer system to avoid illicit discharges.
- Ensure that sanitary/septic facilities are maintained in good working order by a licensed service.
- Use only reputable, licensed sanitary/septic waste haulers.
- Clean up spills and leaks immediately. Spills and leaks shall not be covered or buried onsite. Contaminated soil shall be disposed of properly in accordance with permits, laws and regulations.
- Inspect sanitary and septic waste facilities weekly, and before and after every rainfall events. During extended rainfall events, inspect sanitary and septic waste facilities at least once every 24 hours.

## Maintenance and Inspection



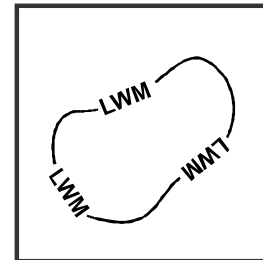
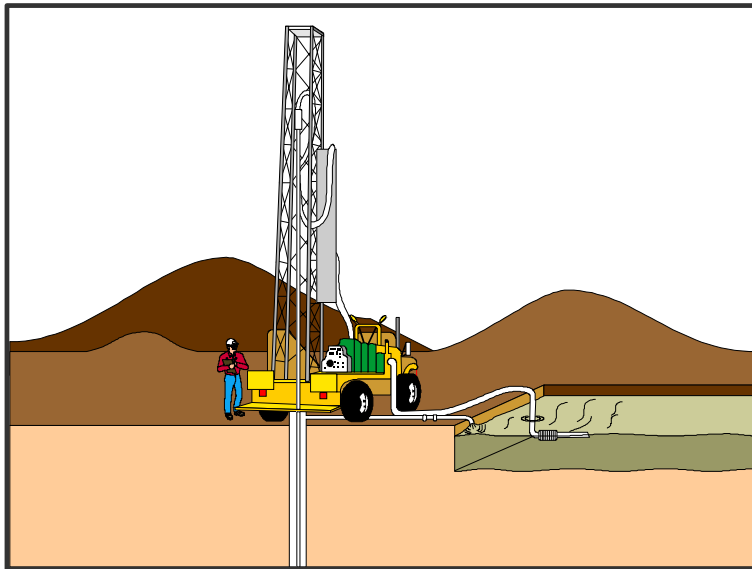

Standard Symbol

### BMP Objectives

- Soil Stabilization
- Sediment Control
- Tracking Control
- Wind Erosion Control
- Non-Storm Water Management
- Materials and Waste Management

**Definition and Purpose** Procedures and practices to prevent discharge of pollutants to the ground, storm drain system or to watercourses as a result of the creation, collection, and disposal of non-hazardous liquid wastes.

**Appropriate Applications** Liquid waste management is applicable to construction sites that generate any non-hazardous byproducts, residuals, or wastes not limited to the following:

- Drilling slurries and drilling fluids.
- Grease-free and oil-free wastewater and rinse water.
- Dredgings.
- Other non-storm water liquid discharges not permitted by separate permits.

**Limitations** ■ Disposal of some liquid wastes may be subject to requirements of other permits secured by the Agency (e.g., National Pollutant Discharge Elimination System [NPDES] permits, Army Corps of Engineers permits, RWQCB Water Quality Certifications, Coastal Commission permits, etc.).

- Does not apply to groundwater dewatering operations (refer to contract Special Provisions)
- Does not apply to dewatering operations (see BMP NS-2, “Dewatering Operations”), solid waste management (see BMP WM-5, “Solid Waste Management”), hazardous wastes (see BMP WM-6, “Hazardous Waste Management”), or concrete slurry residue (see BMP WM-8, “Concrete Waste Management”).
- Does not apply to approved non-storm water discharges permitted by any NPDES permit secured by the Agency. Typical permitted non-storm water discharges can include: fire hydrant flushing, irrigation of vegetative erosion control measures, pipe flushing and testing, water to control dust,

uncontaminated ground water from dewatering fire hydrant flushing, irrigation of vegetative erosion control measures, pipe flushing and testing, or water to control dust.

## Standards and Specifications

### **General Practices**

- Instruct employees and subcontractors how to safely differentiate between non-hazardous liquid waste and potential or known hazardous liquid waste. Educate employees and subcontractors on liquid waste generating activities, and liquid waste storage and disposal procedures. Hold regular meetings to discuss and reinforce disposal procedures (incorporate into regular safety meetings).
- Instruct employees, subcontractors, and suppliers that it is unacceptable for any liquid waste to discharge to the ground, or enter any storm drainage structure, waterway, or receiving water.
- Verify with the Engineer which non-storm water discharges are permitted. Some listed discharges may be prohibited if the Agency determines the discharge to be a source of pollutants.
- Apply the NS-8, “Vehicle and Equipment Cleaning” BMP for managing wash water and rinse water from vehicle and equipment cleaning operations.

### **Containment of Liquid Wastes**

- Drilling residue and drilling fluids shall not be allowed to discharge to the ground, or enter storm drains and watercourses and shall be disposed of in conformance with all applicable laws and regulations.
- Liquid wastes generated as part of an operational procedure, such as water-laden dredged material and drilling mud, shall be contained and not allowed to discharge to the ground or to flow into drainage channels or receiving waters prior to treatment and meeting water quality requirements.
- Contain liquid wastes in a controlled area, such as a sediment basin, watertight roll-off bin, or portable tank.
- Containment devices must be structurally sound and leak free.
- Containment devices must be of sufficient quantity or volume to completely contain the liquid wastes generated.
- Take precautions to avoid spills or accidental releases of contained liquid wastes. Apply the education measures and spill response procedures outlined in BMP WM-4, “Spill Prevention and Control.”
- Do not locate containment areas or devices where accidental release of the contained liquid can threaten health or safety, or discharge to water bodies, channels, or storm drains.

- Contain and properly dispose off-site all liquid wastes running off a surface such as wash water and rinse water from cleaning walls or pavement.
- Do not allow liquid wastes to flow or discharge uncontrolled to the ground, storm drain system or watercourse. Use temporary dikes or berms to intercept flows and direct them to a containment area.
- Use a sediment trap (see BMP SC-3, “Sediment Trap”) for capturing and treating the liquid waste stream, or capture in a containment device and allow sediment to settle.

### ***Disposal of Liquid Wastes***

- All liquid waste must be disposed of offsite. If liquid waste is allowed to be discharged to the storm drain system in accordance with permits, laws and regulations, the discharge shall be approved by the Engineer,
- Dispose of liquid wastes as required in the contract Special Provisions or per the Water Quality Reports, NPDES permits, Environmental Impact Reports, 401 Water Quality Certifications or 404 permits, local agency discharge permits, etc., or as specified in the contract Special Provisions.
- Liquid wastes, such as from dredged material, may require testing and certification whether it is hazardous or not before a disposal method can be determined. Sampling is the responsibility of the Contractor unless specified in the contract Special Provisions.
- For disposal of hazardous waste, see BMP WM-6, “Hazardous Waste Management.”
- If necessary, further treat liquid wastes prior to disposal. Treatment may include, though is not limited to, sedimentation, filtration, and chemical neutralization.

### **Maintenance and Inspection**

- Inspect all liquid waste management facilities weekly, and before and after every rainfall events. During extended rainfall events, inspect liquid waste management facilities at least once every 24 hours.
- Inspect containment areas and capturing devices frequently for damage, and repair as needed. Remove deposited solids in containment areas and capturing devices as needed, and at the completion of the task. Dispose of any solids as described in BMP WM-5, “Solid Waste Management.”



(This page left intentionally blank)

# Appendix A

## Abbreviations, Acronyms, and Definition of Terms

### Abbreviations

ac	acre	L <sub>a</sub>	apron length
°C	Degrees Celsius	lb	pound
cfs	cubic feet per second	lf	linear feet
cy	cubic yards	m	meter
dia	diameter	mils	thousandths of an inch
d <sub>o</sub>	outer diameter	min	minimum
e.g.	for example	max	maximum
eq.	equation	mm	millimeter
etc.	et cetera	nts	not to scale
°F	Degrees Fahrenheit	oz	ounce
ft	feet	psi	pounds per square inch
ft <sup>3</sup>	cubic feet	R	radius
g	gram	s	second
gal	gallon	sec <sup>-1</sup>	per second
gpm	gallons per minute	typ	typical
hr	hour	UV	ultraviolet
i.e.	such as	yd	yard
in	inches	y <sup>2</sup>	square yards
		y <sup>3</sup>	cubic yards

### Acronyms

AC	Asphalt Concrete	AST	aboveground storage tank
ABS	Acrylonitrile Butadiene Styrene	ASTM	American Society of Testing Materials
ADL	Aerially Deposited Lead	BAT	Best Available Technology
AQMD	Air Quality Management District	BCT	Best Conventional Technology
APP	Accumulated Precipitation Procedure	BMP	Best Management Practice
		BFM	bonded fiber matrix
		BOD	biological oxygen demand



CAL-EPA	California Environmental Protection Agency	RWQCB	California Regional Water Quality Control Board
CAL-OSHA	California Occupational Safety and Health Administration	SCS	Soil Conservation Service
CASQA	California Stormwater Quality Association	SSP	Standard Special Provisions
CCR	California Code of Regulations	SWMP	Storm Water Management Plan
CCS	Cellular confinement system	SWPPP	Storm Water Pollution Prevention Plan
CMP	Corrugated Metal Pipe	SWRCB	California State Water Resources Control Board
CFR	Code of Federal Regulations	TSS	total suspended solids
DHS	California Department of Health Services	V:H	Vertical versus Horizontal
DSA	Disturbed Soil Area	USDA	United States Department of Agriculture
EC	erosion control	USDOT	United States Department of Transportation
ECU	Environmental Compliance Unit	US EPA	United States Environmental Protection Agency
ESA	Environmentally Sensitive Area	USLE	Universal Soil Loss Equation
FEMA	Federal Emergency Management Agency	WDID	Waste Discharge Identification
Haz Mat	hazardous material	WDR	Waste Discharge Requirement
HDPE	high density polyethylene	WPCD	water pollution control drawing
L:W	Length versus Width		
MS4	Municipal Separate Storm Sewer System		
MSDS	Material Safety Data Sheet		
MUSLE	Modified Universal Soil Loss Equation		
OSHA	Occupational Safety and Health Administration		
PCC	Portland Cement Concrete		
PLS	pure live seed		
PVC	Polyvinyl Chloride		
QSP	Qualified SWPPP Practitioner		
RECP	rolled erosion control product		





## Definition of Terms

**Active Areas of Construction:** All areas subject to land surface disturbance activities related to the project including, but not limited to, the project site, project staging areas, immediate access areas and storage areas. All previously active areas are still considered active areas until final stabilization is complete. [The construction activity Phases are the Preliminary Phase, Grading and Land Development Phase, Streets and Utilities Phase, and the Vertical Construction Phase.]

**Antecedent Moisture:** Amount of moisture present in soil prior to the application of a soil stabilization product.

**Best Management Practice (BMP):** BMPs are scheduling of activities, prohibitions of practices, maintenance procedures, and other management practices to prevent or reduce the discharge of pollutants. BMPs also include treatment requirements, operating procedures, and practices to control site runoff, spillage or leaks, sludge or waste disposal, or drainage from raw material storage. Any program, technology, process, siting criteria, operating method, measure, or device that controls, prevents, removes, or reduces pollution.

**Construction Activity:** Includes clearing, grading, or excavation and contractor activities that result in soil disturbance.

**Construction Site:** The area involved in a construction project as a whole including but not limited to the project site, storage areas, access roads, staging areas, drainage areas.

**Contamination:** An impairment of the quality of the waters of the state by waste to a degree that creates a hazard to the public health through poisoning or through the spread of disease including any equivalent effect resulting from the disposal of waste, whether or not waters of the state are affected.

**Contractor:** Party responsible for carrying out the contract per plans and specifications. The contract Special Provisions contain storm water protection requirements the contractor must address.

**Degradability:** Method by which the chemical components of a soil stabilization product are degraded over time.

**Discharge:** Any release, spill, leak, pump, flow, escape, dumping, or disposal of any liquid, semi-solid or solid substance.

**Disturbed Areas:** Areas that have been purposefully cleared, grubbed, excavated, or graded by the contractor; ground surface that has been disrupted by construction activities, including construction access/roads, producing significant areas of exposed soil and soil piles. Staging and storage sites are considered as part of the total disturbed land area, whether located on or off the project site.

**Drying Time:** Time it takes for a soil stabilization product to dry or cure for it to become erosion control effective.



**Engineer:** Agency representative on a construction project. The Engineer may be the inspector or engineer representing the Agency on site.

**Environmental Protection Agency (EPA):** Federal Agency that issues the regulations to control pollutants in storm water runoff discharges (The Clean Water Act and NPDES permit requirements).

**Erosion:** The process, by which soil particles are detached and transported by the actions of wind, water, or gravity.

**Erosion Control Effectiveness:** The ability of a particular product to reduce soil erosion relative to the amount of erosion measured for bare soil. Percentage of erosion that would be reduced as compared to an untreated or control condition.

**Exempt Construction Activities:** Activities exempt from the Construction General Permit, including routine maintenance to maintain original line and grade, hydraulic capacity, or original purpose of the facility; and emergency construction activities required to protect public health and safety. Local permits may not exempt these activities.

**Existing vegetation:** Any vegetated area that has not already been cleared and grubbed.

**Fair Weather Prediction:** When there is no precipitation in the forecast between the current calendar day and the next working day. The National Weather Service NOAA Weather Radio forecast shall be used. The contractor may propose an alternative forecast for use if approved by the Resident Engineer.

**Feasible:** Economically achievable or cost-effective measures which reflect a reasonable degree of pollutant reduction achievable through the application of available nonpoint pollution control practices, technologies, processes, site criteria, operating methods, or other alternatives.

**General Permit:** The General Permit for Storm Water Discharges Associated with Construction Activity (Order No. 99-08-DWQ, NPDES Permit CAS000002) issued by the State Water Resources Control Board.

**Good Housekeeping:** A common practice related to the storage, use, or cleanup of materials, performed in a manner that minimizes the discharge of pollutants.

**Local permit:** See MS4 Permit.

**Longevity:** The time the soil erosion product maintains its erosion control effectiveness.

**Mode of Application:** Type of labor or equipment that is required to install the product or technique.

**MS4 Permit:** Regional Water Quality Control Board (RWQCB) – Los Angeles Region, adopted Order No. 01-182, NPDES Permit No. CAS004001, Waste Discharge Requirements for Municipal Storm Water and Urban Runoff Discharge within the County of Los Angeles, and Incorporated Cities Therein. This is commonly referred to as MS4 permit or local NPDES permit.



**National Pollutant Discharge Elimination System (NPDES) Permit:** A permit issued pursuant to the Clean Water Act that requires the discharge of pollutants to waters of the United States from storm water be controlled.

**Native:** Living or growing naturally in a particular region. Compatibility and competitiveness of selected plant materials with the environment.

**Non-active Construction Area:** Any area not considered to be an active construction area. Active construction areas become non-active construction areas whenever construction activities are expected to be discontinued for a period of 14 days or longer.

**Non-Storm Water Discharges:** Discharges that do not originate from precipitation events. They can include, but are not limited to, discharges of process water, air conditioner

condensate, non-contact cooling water, vehicle wash water, water truck water, sanitary wastes, concrete washout water, paint wash water, irrigation water, or pipe testing water.

**Permit:** The Construction General Permit or local MS4 NPDES permit, whichever or both are applicable to the construction project.

**Pollution:** The man-made or man-induced alteration of the chemical, physical, biological, and radiological integrity of water. An alteration of the quality of the water of the state by waste to a degree, which unreasonably affects either the waters for beneficial uses or facilities that serve these beneficial uses.

**Qualified SWPPP Practitioner (QSP):** Individual assigned responsibility for non-storm water and storm water visual observations, sampling and analysis, and responsibility to ensure full compliance with the contract Special Provisions and implementation of all elements of the SWPPP.

**Receiving Waters:** All surface water bodies within the County of Los Angeles.

**Regional Water Quality Control Board (RWQCB):** California agencies that implement and enforce Clean Water Act Section 402(p) NPDES permit requirements, and are issuers and administrators of these permits as delegated by EPA. There are nine regional boards working with the State Water Resources Control Board.

**Residual Impact:** The impact that a particular practice might have on construction activities once they are resumed on the area that was temporarily stabilized.

**Runoff Control BMPs:**

Measures used to slow and convey concentrated flow, dissipate velocity to prevent or minimize erosion and sediment discharges.

**Runoff Effect:** The effect that a particular soil stabilization product has on the production of storm water runoff. Runoff from an area protected by a particular product may be compared to the amount of runoff measured for bare soil.



**Run-on:** Discharges that originate offsite and flow onto the property of a separate project site.

**Run-on Control BMPs** - Measures used to divert run-on from offsite and runoff within the project site.

**Sediment:** Solid particulate matter, both mineral and organic, that is in suspension, is being transported, or has been moved from its site of origin by air, water, gravity, or ice and has come to rest on the earth's surface either above or below sea level.

**Sediment Control BMPs:** Practices that trap soil particles after they have been eroded by rain, flowing water, or wind. They include those practices that intercept and slow or detain the flow of storm water to allow sediment to settle and be trapped (e.g., silt fence, sediment basin, fiber rolls, etc.).

**Statewide Permit:** The National Pollutant Discharge Elimination System (NPDES) Permit, Statewide Storm Water Permit and Waster Discharge Requirements (WDRs) for the State of California Department of Transportation (Caltrans). Order No. 99-06-DWQ, NPDES No. CAS000003.

**State Water Resources Control Board (SWRCB):** California agency that implements and enforces Clean Water Act Section 402(p) NPDES permit requirements, is issuer and administrator of these permits as delegated by EPA. Works with the nine Regional Water Quality Control Boards.

**Storm Drain System:** Streets, gutters, inlets, conduits, natural or artificial drains, channels and watercourses, or other facilities that are owned, operated, maintained and used for the purpose of collecting, storing, transporting, or disposing of storm water.

**Storm Water:** Rainfall runoff, snow melt runoff, and surface runoff and drainage. It excludes infiltration and runoff from agricultural land.

**Storm Water Pollution Prevention Plan (SWPPP):** A plan required by the Permit that includes site map(s), an identification of construction/contractor activities that could cause pollutants in the storm water, and a description of measures or practices to control these pollutants. It must be prepared and approved in accordance with the contract special provisions and the LACDPW SWPPP Preparation Manual before construction begins.

**Temporary Construction Site BMPs:** Construction Site BMPs that are required only temporarily to address a short-term storm water contamination threat. For example, silt fences are located near the base of newly graded slopes that have a substantial area of exposed soil. Then, during rainfall, the silt fences filter and collect sediment from runoff flowing off the slope.

**Waste Discharge Identification Number (WDID):** The unique project number issued by the SWRCB upon receipt of the notice of intent (NOI).



# Appendix B

## Best Management Practices (BMP) Checklist

### General

- The BMP Checklist is available as a separate Excel file.
- Use this BMP Checklist for documenting all inspections. This BMP Checklist meets the Construction General Permit requirements for BMP inspections, storm event inspections, and non-storm water inspections (quarterly inspections).
- In order to properly fill out the BMP Checklist, these instructions must be followed. The BMP Checklist does not provide instruction on how to conduct the inspection and fill out the BMP Checklist. BMP design, implementation, and maintenance for the BMPs numbered and named on the BMP Checklist are detailed in the BMP Fact Sheets attached to Sections 3 through 8 of this BMP Manual.
- For SWPPP projects, the BMP Checklist shall be completed and signed by the Contractor's Qualified SWPPP Practitioner (QSP).
- Evaluate BMPs for adequacy and proper maintenance and whether additional BMPs are required in accordance with the contract Special Provisions and the Construction General Permit (Order No. 2009-0009-DWQ).
- All paved areas that provide access to the project site shall be inspected daily. The question, "Are all paved roads that provide access to the project inspected daily for tracking of sediment and other debris?" shall be answered.
- If the answer is "no" to any of the questions listed in Columns B, C, or D of the BMP Checklist, describe the corrective action(s) to be taken and implementation dates of when corrective actions are completed. Should more space be needed to describe corrective actions, identify the corrective action numerically and use additional sheets as necessary.
- The inspection type is documented to ensure and document that inspections are conducted with the required frequency. Check either "Weekly," "Pre-storm," "Post-storm," "During" or "Other." If "other" is checked, describe what type of inspection in the space provided. For example, if an inspection is conducted more frequently than once per week, the "Other" box should be checked and the inspector shall fill in "additional weekly" for the inspection type. Another example would be a consultant or oversight inspection or audit.

### Project Information

- The Project Name and Project ID Number shall be obtained from the front cover of the contract Special Provisions.
- The PCA number is an internal LACDPW billing number not necessary for the Contractor to fill in. The Office Engineer and Area Supervisor and signature are not necessary for the Contractor to fill in.
- If the BMP Checklist is used for a catch basin cleanout contract, referred to specific BMPs that may apply: SS-1, SS-7, SS-10, NS-6, WM-2, WM-4, WM-5, WM-6.



### **Inspector's name, title, and signature**

- For SWPPP projects, the inspector shall be Contractor's Qualified SWPPP Practitioner (QSP). The QSP name, title and signature are required. For projects that do not require a SWPPP, the inspector is the Contractor staff responsible for the BMPs.

### **SWPPP Projects**

- Whether the project requires a SWPPP is determined by Section 7-8.6 of the Contract Special Provisions. SWPPP projects are required to answer the question in Column "A" whether each BMP is included in the SWPPP. Projects that do not require a SWPPP are not required to answer the question in Column "A."
- Whether SWPPP revisions are necessary shall be based on the entire inspection and review of the SWPPP.
- The inspector shall review the SWPPP prior to an inspection in order to determine whether a SWPPP amendment is necessary.
- If the SWPPP adequately addresses installed BMPs and BMPs required for the project, and if the SWPPP matches the site, answer "no" to indicate that amendments to the SWPPP are NOT necessary.
- If the SWPPP does not match the actual construction site conditions or if corrective actions need to be made on the site that do not match the current SWPPP, answer "yes" to indicate that SWPPP amendments are necessary. If "yes" is checked, include SWPPP amendments as part of the corrective actions for the associated BMPs in the BMP Checklist Section 1 thru 6.
  - For example, if during an inspection a drain inlet is identified that was not shown on the project SWPPP, the question regarding whether the SWPPP revisions are necessary should be answered "yes." Then, under Section 2, SC-10 Storm Drain Inlet Protection, not only should any deficiencies, corrective actions and implementation dates for the BMP inspected be noted, but an additional deficiency, corrective action, and implementation date should be noted to amend the SWPPP to include the additional drain inlet location.
  - For another example, if the Contractor implements an additional BMP, approved by the Engineer, such as a fiber roll to break up slope lengths, and fiber rolls were not previously selected, included and described in the SWPPP, the corrective actions under SC-5 Fiber Rolls shall include a revision to the SWPPP to add fiber rolls.

### **Inspection date, time, and date the inspection report was written**

- The inspection report shall be completed the same day that the inspection was conducted. In order to document that the inspection was completed the same day, both the inspection date and report date are required.
- The report number is a consecutive number from the first inspection conducted on the project.



**Stage of construction, activities completed, and approximate area of the site exposed.**  
**(SWPPP Projects Only)**

- The area of construction exposed shall be approximated in acres. Exposed areas include but are not limited to:
  - Clearing of the land both for access (i.e. access roads) as well as preparing the site for construction,
  - Construction of access roads and existing unpaved roads,
  - excavation and grading of the site,
  - equipment staging, maintenance, and construction easement areas if they occur on top of a soil surface,
  - material and/or soil staging or stockpiles if atop a soil surface (not if atop an impervious surface such as concrete or asphalt),
  - area of asphalt or concrete pavement removal if it is removed entirely to the soil surface,
  - area related to demolition and removal of existing structures if the work is to the soil surface,
  - concrete truck clean-out or other construction activity areas if on top of a soil surface
- The stage of construction shall be documented by checking one or more of the boxes on the BMP Checklist for utilities, grading/excavating/drilling, paving/general construction, vertical, or final landscaping/stabilization.
- The activities completed shall be filled in. This information is project-specific and shall be updated for each inspection as construction progresses. For example, if sawcutting operations were completed and the project was working on utilities, write “sawcutting” as a completed activity. If paving operations were completed and the project was in landscaping, write “paving” as a completed activity. If the project had completed a portion of paving but was still conducting paving, write a percentage of paving as a completed activity (e.g., “40% paving”). There may be more than one activity completed. For example, if the excavation, backfill, and utility work were completed and the project was being paved, write “excavation, backfill and utility work” as completed activities.

**Weather Information (SWPPP Projects Only)**

- If it is raining or drizzling during the inspection answer “yes” to was precipitation present during inspection. Otherwise, answer “no.”
- The beginning time of the storm event shall be documented when the rain event starts during working hours. If the rain event begins outside work hours, include an estimate of the start time. For example, if it started raining after leaving the site at 3:00 p.m. and before arriving at 7:00 a.m., the beginning must be estimated.
- The elapsed time since the last rain event shall be obtained by reviewing the previous rain event BMP Checklists and counting the days in between events.
- Rainfall/Rain gauge information shall be monitored daily during a rain event. The



inches of rain that has fallen shall be obtained from the Los Angeles County Department of Public Works, Water Resources Division, Hydrology Precipitation Map. The rain gauge for the past 24 hours shall be obtained from the website. Select the closest rain gauge station to the project site location at [http://ladpw.org/wrd/precip/alert\\_rain/](http://ladpw.org/wrd/precip/alert_rain/) and click on the 24-hour tab at the top of the page. Record the rain in inches and the name of the selected rain gauge station on the BMP Checklist. The rain gauge shall be monitored at the same time each day.

- Estimate the time of the duration of the rain event for the day the inspection was conducted.

### **Odors, sheens, turbidity, floating or suspended material or discoloration**

- Inspect water discharges for any odors, sheens, turbidity, floating or suspended material or discoloration on the surface. Answer “yes” or “no” to whether there are any odors, sheens, turbidity, floating or suspended materials or discoloration noticed during the inspection. If there is no water discharge noticed, answer not applicable “N/A.” If “yes” is the answer identify the source and describe in the space provided.
  - For example, if a sheen is noticed on the surface of the discharge, look upgradient to find and identify the location of the oil/grease/fuel that may have been the source of the sheen and document the findings. The source may have been a leaking vehicle or equipment. The corrective action shall be documented under the BMP Checklist section that addresses vehicles and equipment (See Section 5, NS-8, NS-9, and NS-10)

### **Description of any BMPs evaluated and any deficiencies noted as well as locations.**

- Answer whether each BMP is deployed on site, whether the BMPs are adequately designed and implemented, and whether the BMPs are maintained and effective.
- Locations, deficiencies, corrective actions and implementation dates shall be noted in the space allotted or additional sheets shall be attached. The locations may be referenced to the SWPPP water pollution control drawings (WPCDs) or called out specifically.
  - For example, if the Storm Drain Inlet Protection BMPs are implemented on all drain inlets as shown on the WPCDs, reference to the WPCDs would be adequate.
- If BMPs need maintenance, the locations of each BMP deficiency (e.g., BMP that requires maintenance) shall be identified.
  - For example, “the gravel bag barrier along South St. between Broad Ave. and Park Ave. has broken bags that require replacement.”

### **Corrective actions required and the associated implementation dates.**

- The corrective actions may include implementation of BMPs, maintenance, repair or replacement.
  - For example, the stockpile BMPs under WM-3 may have plastic covers on stockpiles that are no actively being used that have been displaced and need to be replaced. The corrective action shall require a cover and berm for





stockpiles not actively being used. In addition, once the corrective actions have been implemented, the implementation date shall be entered.

- Corrective actions identified on the BMP Checklist shall be implemented by the end of the day of the inspection. If the corrective actions are not completed the same day, enforcement action will be taken. If 2 days can be allowed to complete a corrective action, a Notice of BMP Noncompliance form shall be completed and issued to the Contractor. If 2 days cannot be allowed, the Engineer may implement other enforcement actions or begin monetary penalties immediately.
- The corrective action for SWPPP amendment may require more time than “by the end of day.” In case a corrective action requires more time than the end of the day, the inspector must track the implementation and document that the SWPPP was amended to complete the BMP Checklist. SWPPP amendments must be completed in accordance with the contract Special Provisions Section 7-8.6.3.7.
- The BMP Checklist must indicate implementation dates of when corrective actions are completed.

**Photographs taken during the inspection, if any.**

- Photographs if taken during the inspection shall be documented at the end of the inspection form and attached. If more space is needed, attach additional sheets.



(This page left intentionally blank)



LOS ANGELES COUNTY DEPARTMENT OF PUBLIC WORKS  
CONSTRUCTION DIVISION

BEST MANAGEMENT PRACTICES (BMP) CHECKLIST  
INSTRUCTIONS

**PURPOSE:** To verify the Contractor's effective implementation and maintenance of Best Management Practices (BMPs), and compliance with the project's Storm Water Pollution Prevention Plan (SWPPP).

**PROCEDURE:** The LACDPW Staff shall thoroughly evaluate each project site and complete all sections of the form. The detailed instructions for filling out the BMP Checklist included in the BMP Manual and Staff Guide must be followed. The BMP Checklist must be signed by the LACDPW Staff inspector and the Area Supervisor.

The LACDPW Staff shall indicate on the checklist, which BMPs are identified in the Contractor's County certified SWPPP with the actual BMPs being deployed on the project. The LACDPW Staff shall indicate whether the BMPs are adequately designed and implemented, maintained and effective. The location, deficiency, corrective action and implementation date must be provided under the comments for any BMP not adequately designed, implemented or maintained and effective.

When one or more of the BMPs have not been effectively designed, implemented or maintained, the LACDPW Staff shall:

1. Verbally discuss the problem with the Contractor's Qualified SWPPP Practitioner (QSP).
2. If the problem is not resolved by the end of the same working day, the LACDPW Staff shall complete a Notice of BMP Noncompliance form which directs the Contractor to take immediate action to implement or maintain the BMP on the project and/or to make appropriate amendments to the project SWPPP. See Notice of BMP Noncompliance form for further instructions if not corrected by end of day.

**FREQUENCY:** Weekly and before, during and after each storm.

**DISTRIBUTION:** Original report shall be forwarded to the Office Engineer with each week's project records. A copy shall be retained in the field project files and a copy shall be given to the Contractor.

(This page left intentionally blank)



LOS ANGELES COUNTY DEPARTMENT OF PUBLIC WORKS

BEST MANAGEMENT PRACTICES (BMP) CHECKLIST

Project Name: \_\_\_\_\_ PCA No.: \_\_\_\_\_ Report No: \_\_\_\_\_  
 Contractors Name: \_\_\_\_\_ Project ID No.: \_\_\_\_\_ Inspection Time: \_\_\_\_\_  
 Inspector: \_\_\_\_\_ Title: \_\_\_\_\_ Inspection Date: \_\_\_\_\_  
 Signature: \_\_\_\_\_ Office Engineer: \_\_\_\_\_ Report Date: \_\_\_\_\_

Area Supervisor: \_\_\_\_\_  
 Signature: \_\_\_\_\_  
 Approximate area of construction exposed (acres): \_\_\_\_\_  
 Are all paved roads that provide access to the project inspected daily for tracking of sediment and other debris?  Yes  No  
 Inspection Type:  Weekly  Pre-Storm  Post-Storm  During  Other \_\_\_\_\_  
 Stage of construction:  Utilities  Grading/excavation/drilling  Paving/general construction  Vertical  Final landscaping/stabilization  
 Construction activities completed: \_\_\_\_\_

Does this project require a SWPPP?  Yes  No  
 If yes, complete Columns A, B, C, and D. If no, complete Columns B, C, and D.  
 Are SWPPP amendments necessary?  Yes  No  N/A

**Weather Information: (SWPPP Projects ONLY)**  
 Was precipitation present during inspection?  Yes  No Rainfall/Rain Gauge (in.) \_\_\_\_\_  
 Beginning time of storm event: \_\_\_\_\_ Rain Station: \_\_\_\_\_  
 Elapsed time since last rain event: \_\_\_\_\_ Duration of event: \_\_\_\_\_

Are there any odors, sheens, turbidity, floating or suspended materials, discoloration on any water discharges?  Yes  No  N/A  
 If yes, describe the source: \_\_\_\_\_

Catch Basin Cleanout Contract?  Yes  No If yes, see only: SS-1, SS-7, SS-10, NS-6, WM-2, WM-4, WM-5, WM-6

**1. Temporary Soil Stabilization Practices**

A. Included in SWPPP?		BMP Description	B. Deployed on Site?		C. Adequately designed/implemented?			D. Maintained/effective?			Location/Deficiencies/Corrective Actions/Implementation Dates
Yes	No		Yes	No	Yes	No	N/A	Yes	No	N/A	
<input type="checkbox"/>	<input type="checkbox"/>	SS-1	Scheduling	<input type="checkbox"/>	<input type="checkbox"/>	<input type="checkbox"/>	<input type="checkbox"/>	<input type="checkbox"/>	<input type="checkbox"/>	<input type="checkbox"/>	
<input type="checkbox"/>	<input type="checkbox"/>	SS-2	Preserve Existing Vegetation	<input type="checkbox"/>	<input type="checkbox"/>	<input type="checkbox"/>	<input type="checkbox"/>	<input type="checkbox"/>	<input type="checkbox"/>	<input type="checkbox"/>	
<input type="checkbox"/>	<input type="checkbox"/>	SS-3	Hydraulic Mulch	<input type="checkbox"/>	<input type="checkbox"/>	<input type="checkbox"/>	<input type="checkbox"/>	<input type="checkbox"/>	<input type="checkbox"/>	<input type="checkbox"/>	
<input type="checkbox"/>	<input type="checkbox"/>	SS-4	Hydroseeding	<input type="checkbox"/>	<input type="checkbox"/>	<input type="checkbox"/>	<input type="checkbox"/>	<input type="checkbox"/>	<input type="checkbox"/>	<input type="checkbox"/>	
<input type="checkbox"/>	<input type="checkbox"/>	SS-5	Soil Binders	<input type="checkbox"/>	<input type="checkbox"/>	<input type="checkbox"/>	<input type="checkbox"/>	<input type="checkbox"/>	<input type="checkbox"/>	<input type="checkbox"/>	
<input type="checkbox"/>	<input type="checkbox"/>	SS-6	Straw Mulch	<input type="checkbox"/>	<input type="checkbox"/>	<input type="checkbox"/>	<input type="checkbox"/>	<input type="checkbox"/>	<input type="checkbox"/>	<input type="checkbox"/>	
<input type="checkbox"/>	<input type="checkbox"/>	SS-7	Geotextiles/Plastic/EC Blankets/Mats	<input type="checkbox"/>	<input type="checkbox"/>	<input type="checkbox"/>	<input type="checkbox"/>	<input type="checkbox"/>	<input type="checkbox"/>	<input type="checkbox"/>	
<input type="checkbox"/>	<input type="checkbox"/>	SS-8	Wood Mulching	<input type="checkbox"/>	<input type="checkbox"/>	<input type="checkbox"/>	<input type="checkbox"/>	<input type="checkbox"/>	<input type="checkbox"/>	<input type="checkbox"/>	
<input type="checkbox"/>	<input type="checkbox"/>	SS-9	Earth dikes/drainage swales and	<input type="checkbox"/>	<input type="checkbox"/>	<input type="checkbox"/>	<input type="checkbox"/>	<input type="checkbox"/>	<input type="checkbox"/>	<input type="checkbox"/>	
<input type="checkbox"/>	<input type="checkbox"/>	SS-10	Outlet Protection/Velocity Dissipation	<input type="checkbox"/>	<input type="checkbox"/>	<input type="checkbox"/>	<input type="checkbox"/>	<input type="checkbox"/>	<input type="checkbox"/>	<input type="checkbox"/>	
<input type="checkbox"/>	<input type="checkbox"/>	SS-11	Slope Drains	<input type="checkbox"/>	<input type="checkbox"/>	<input type="checkbox"/>	<input type="checkbox"/>	<input type="checkbox"/>	<input type="checkbox"/>	<input type="checkbox"/>	
<input type="checkbox"/>	<input type="checkbox"/>	SS-12	Streambank Stabilization	<input type="checkbox"/>	<input type="checkbox"/>	<input type="checkbox"/>	<input type="checkbox"/>	<input type="checkbox"/>	<input type="checkbox"/>	<input type="checkbox"/>	

**2. Temporary Sediment Control Practices**

A. Included in SWPPP?		BMP Description	B. Deployed on Site?		C. Adequately designed/implemented?			D. Maintained/effective?			Location/Deficiencies/Corrective Actions/Implementation Dates
Yes	No		Yes	No	Yes	No	N/A	Yes	No	N/A	
<input type="checkbox"/>	<input type="checkbox"/>	SC-1	Silt Fence	<input type="checkbox"/>	<input type="checkbox"/>	<input type="checkbox"/>	<input type="checkbox"/>	<input type="checkbox"/>	<input type="checkbox"/>	<input type="checkbox"/>	
<input type="checkbox"/>	<input type="checkbox"/>	SC-2	Desilting Basin	<input type="checkbox"/>	<input type="checkbox"/>	<input type="checkbox"/>	<input type="checkbox"/>	<input type="checkbox"/>	<input type="checkbox"/>	<input type="checkbox"/>	
<input type="checkbox"/>	<input type="checkbox"/>	SC-3	Sediment Trap	<input type="checkbox"/>	<input type="checkbox"/>	<input type="checkbox"/>	<input type="checkbox"/>	<input type="checkbox"/>	<input type="checkbox"/>	<input type="checkbox"/>	
<input type="checkbox"/>	<input type="checkbox"/>	SC-4	Check Dam	<input type="checkbox"/>	<input type="checkbox"/>	<input type="checkbox"/>	<input type="checkbox"/>	<input type="checkbox"/>	<input type="checkbox"/>	<input type="checkbox"/>	
<input type="checkbox"/>	<input type="checkbox"/>	SC-5	Fiber Rolls	<input type="checkbox"/>	<input type="checkbox"/>	<input type="checkbox"/>	<input type="checkbox"/>	<input type="checkbox"/>	<input type="checkbox"/>	<input type="checkbox"/>	
<input type="checkbox"/>	<input type="checkbox"/>	SC-6	Gravel Bag Berm	<input type="checkbox"/>	<input type="checkbox"/>	<input type="checkbox"/>	<input type="checkbox"/>	<input type="checkbox"/>	<input type="checkbox"/>	<input type="checkbox"/>	
<input type="checkbox"/>	<input type="checkbox"/>	SC-7	Street Sweeping and Vacuuming	<input type="checkbox"/>	<input type="checkbox"/>	<input type="checkbox"/>	<input type="checkbox"/>	<input type="checkbox"/>	<input type="checkbox"/>	<input type="checkbox"/>	
<input type="checkbox"/>	<input type="checkbox"/>	SC-8	Sandbag Barrier	<input type="checkbox"/>	<input type="checkbox"/>	<input type="checkbox"/>	<input type="checkbox"/>	<input type="checkbox"/>	<input type="checkbox"/>	<input type="checkbox"/>	
<input type="checkbox"/>	<input type="checkbox"/>	SC-9	Straw Bale Barrier	<input type="checkbox"/>	<input type="checkbox"/>	<input type="checkbox"/>	<input type="checkbox"/>	<input type="checkbox"/>	<input type="checkbox"/>	<input type="checkbox"/>	
<input type="checkbox"/>	<input type="checkbox"/>	SC-10	Storm Drain Inlet Protection	<input type="checkbox"/>	<input type="checkbox"/>	<input type="checkbox"/>	<input type="checkbox"/>	<input type="checkbox"/>	<input type="checkbox"/>	<input type="checkbox"/>	

**3. Wind Erosion Control Practices**

A. Included in SWPPP?		BMP Description	B. Deployed on Site?		C. Adequately designed/implemented?			D. Maintained/effective?			Location/Deficiencies/Corrective Actions/Implementation Dates
Yes	No		Yes	No	Yes	No	N/A	Yes	No	N/A	
<input type="checkbox"/>	<input type="checkbox"/>	WE-1	Wind Erosion Control	<input type="checkbox"/>	<input type="checkbox"/>	<input type="checkbox"/>	<input type="checkbox"/>	<input type="checkbox"/>	<input type="checkbox"/>	<input type="checkbox"/>	

**4. Tracking Control Practices**

A. Included in SWPPP?		BMP Description	B. Deployed on Site?		C. Adequately designed/implemented?			D. Maintained/effective?			Location/Deficiencies/Corrective Actions/Implementation Dates
Yes	No		Yes	No	Yes	No	N/A	Yes	No	N/A	
<input type="checkbox"/>	<input type="checkbox"/>	TC-1	Stabilized Construction Entrance/Exit	<input type="checkbox"/>	<input type="checkbox"/>	<input type="checkbox"/>	<input type="checkbox"/>	<input type="checkbox"/>	<input type="checkbox"/>	<input type="checkbox"/>	
<input type="checkbox"/>	<input type="checkbox"/>	TC-2	Stabilized Construction Roadway	<input type="checkbox"/>	<input type="checkbox"/>	<input type="checkbox"/>	<input type="checkbox"/>	<input type="checkbox"/>	<input type="checkbox"/>	<input type="checkbox"/>	
<input type="checkbox"/>	<input type="checkbox"/>	TC-3	Entrance/Outlet Tire Wash	<input type="checkbox"/>	<input type="checkbox"/>	<input type="checkbox"/>	<input type="checkbox"/>	<input type="checkbox"/>	<input type="checkbox"/>	<input type="checkbox"/>	

**5. Non-Storm Water Management**

A. Included in SWPPP?		BMP Description	B. Deployed on Site?		C. Adequately designed/implemented?			D. Maintained/effective?			Location/Deficiencies/Corrective Actions/Implementation Dates
Yes	No		Yes	No	Yes	No	N/A	Yes	No	N/A	
<input type="checkbox"/>	<input type="checkbox"/>	NS-1	Water Conservation Practices	<input type="checkbox"/>	<input type="checkbox"/>	<input type="checkbox"/>	<input type="checkbox"/>	<input type="checkbox"/>	<input type="checkbox"/>	<input type="checkbox"/>	
<input type="checkbox"/>	<input type="checkbox"/>	NS-2	Dewatering Operations	<input type="checkbox"/>	<input type="checkbox"/>	<input type="checkbox"/>	<input type="checkbox"/>	<input type="checkbox"/>	<input type="checkbox"/>	<input type="checkbox"/>	
<input type="checkbox"/>	<input type="checkbox"/>	NS-3	Paving and Grading Operations	<input type="checkbox"/>	<input type="checkbox"/>	<input type="checkbox"/>	<input type="checkbox"/>	<input type="checkbox"/>	<input type="checkbox"/>	<input type="checkbox"/>	
<input type="checkbox"/>	<input type="checkbox"/>	NS-4	Temporary Stream Crossing	<input type="checkbox"/>	<input type="checkbox"/>	<input type="checkbox"/>	<input type="checkbox"/>	<input type="checkbox"/>	<input type="checkbox"/>	<input type="checkbox"/>	
<input type="checkbox"/>	<input type="checkbox"/>	NS-5	Clear Water Diversion	<input type="checkbox"/>	<input type="checkbox"/>	<input type="checkbox"/>	<input type="checkbox"/>	<input type="checkbox"/>	<input type="checkbox"/>	<input type="checkbox"/>	
<input type="checkbox"/>	<input type="checkbox"/>	NS-6	Illicit Connection/ Illegal Discharge	<input type="checkbox"/>	<input type="checkbox"/>	<input type="checkbox"/>	<input type="checkbox"/>	<input type="checkbox"/>	<input type="checkbox"/>	<input type="checkbox"/>	
<input type="checkbox"/>	<input type="checkbox"/>	NS-7	Potable Water/ Irrigation	<input type="checkbox"/>	<input type="checkbox"/>	<input type="checkbox"/>	<input type="checkbox"/>	<input type="checkbox"/>	<input type="checkbox"/>	<input type="checkbox"/>	
<input type="checkbox"/>	<input type="checkbox"/>	NS-8	Vehicle and Equipment Cleaning	<input type="checkbox"/>	<input type="checkbox"/>	<input type="checkbox"/>	<input type="checkbox"/>	<input type="checkbox"/>	<input type="checkbox"/>	<input type="checkbox"/>	
<input type="checkbox"/>	<input type="checkbox"/>	NS-9	Vehicle and Equipment Fueling	<input type="checkbox"/>	<input type="checkbox"/>	<input type="checkbox"/>	<input type="checkbox"/>	<input type="checkbox"/>	<input type="checkbox"/>	<input type="checkbox"/>	
<input type="checkbox"/>	<input type="checkbox"/>	NS-10	Vehicle and Equipment Maintenance	<input type="checkbox"/>	<input type="checkbox"/>	<input type="checkbox"/>	<input type="checkbox"/>	<input type="checkbox"/>	<input type="checkbox"/>	<input type="checkbox"/>	
<input type="checkbox"/>	<input type="checkbox"/>	NS-11	Pile Driving Operations	<input type="checkbox"/>	<input type="checkbox"/>	<input type="checkbox"/>	<input type="checkbox"/>	<input type="checkbox"/>	<input type="checkbox"/>	<input type="checkbox"/>	
<input type="checkbox"/>	<input type="checkbox"/>	NS-12	Concrete Curing	<input type="checkbox"/>	<input type="checkbox"/>	<input type="checkbox"/>	<input type="checkbox"/>	<input type="checkbox"/>	<input type="checkbox"/>	<input type="checkbox"/>	
<input type="checkbox"/>	<input type="checkbox"/>	NS-13	Material/Equipment Use Over Water	<input type="checkbox"/>	<input type="checkbox"/>	<input type="checkbox"/>	<input type="checkbox"/>	<input type="checkbox"/>	<input type="checkbox"/>	<input type="checkbox"/>	
<input type="checkbox"/>	<input type="checkbox"/>	NS-14	Concrete Finishing	<input type="checkbox"/>	<input type="checkbox"/>	<input type="checkbox"/>	<input type="checkbox"/>	<input type="checkbox"/>	<input type="checkbox"/>	<input type="checkbox"/>	
<input type="checkbox"/>	<input type="checkbox"/>	NS-15	Demo/Removal Over Water	<input type="checkbox"/>	<input type="checkbox"/>	<input type="checkbox"/>	<input type="checkbox"/>	<input type="checkbox"/>	<input type="checkbox"/>	<input type="checkbox"/>	
<input type="checkbox"/>	<input type="checkbox"/>	NS-16	Temporary Batch Plants	<input type="checkbox"/>	<input type="checkbox"/>	<input type="checkbox"/>	<input type="checkbox"/>	<input type="checkbox"/>	<input type="checkbox"/>	<input type="checkbox"/>	

**6. Waste Management and Materials Pollution**

A. Included in SWPPP?		BMP Description	B. Deployed on Site?		C. Adequately designed/implemented?			D. Maintained/effective?			Location/Deficiencies/Corrective Actions/Implementation Dates
Yes	No		Yes	No	Yes	No	N/A	Yes	No	N/A	
<input type="checkbox"/>	<input type="checkbox"/>	WM-1	Material Delivery and Storage	<input type="checkbox"/>	<input type="checkbox"/>	<input type="checkbox"/>	<input type="checkbox"/>	<input type="checkbox"/>	<input type="checkbox"/>	<input type="checkbox"/>	
<input type="checkbox"/>	<input type="checkbox"/>	WM-2	Material Use	<input type="checkbox"/>	<input type="checkbox"/>	<input type="checkbox"/>	<input type="checkbox"/>	<input type="checkbox"/>	<input type="checkbox"/>	<input type="checkbox"/>	
<input type="checkbox"/>	<input type="checkbox"/>	WM-3	Stockpile Management	<input type="checkbox"/>	<input type="checkbox"/>	<input type="checkbox"/>	<input type="checkbox"/>	<input type="checkbox"/>	<input type="checkbox"/>	<input type="checkbox"/>	
<input type="checkbox"/>	<input type="checkbox"/>	WM-4	Spill Prevention and Control	<input type="checkbox"/>	<input type="checkbox"/>	<input type="checkbox"/>	<input type="checkbox"/>	<input type="checkbox"/>	<input type="checkbox"/>	<input type="checkbox"/>	
<input type="checkbox"/>	<input type="checkbox"/>	WM-5	Solid Waste Management	<input type="checkbox"/>	<input type="checkbox"/>	<input type="checkbox"/>	<input type="checkbox"/>	<input type="checkbox"/>	<input type="checkbox"/>	<input type="checkbox"/>	
<input type="checkbox"/>	<input type="checkbox"/>	WM-6	Hazardous Waste Management	<input type="checkbox"/>	<input type="checkbox"/>	<input type="checkbox"/>	<input type="checkbox"/>	<input type="checkbox"/>	<input type="checkbox"/>	<input type="checkbox"/>	
<input type="checkbox"/>	<input type="checkbox"/>	WM-7	Contaminated Soil Management	<input type="checkbox"/>	<input type="checkbox"/>	<input type="checkbox"/>	<input type="checkbox"/>	<input type="checkbox"/>	<input type="checkbox"/>	<input type="checkbox"/>	
<input type="checkbox"/>	<input type="checkbox"/>	WM-8	Concrete Waste Management	<input type="checkbox"/>	<input type="checkbox"/>	<input type="checkbox"/>	<input type="checkbox"/>	<input type="checkbox"/>	<input type="checkbox"/>	<input type="checkbox"/>	
<input type="checkbox"/>	<input type="checkbox"/>	WM-9	Sanitary/Septic Waste Management	<input type="checkbox"/>	<input type="checkbox"/>	<input type="checkbox"/>	<input type="checkbox"/>	<input type="checkbox"/>	<input type="checkbox"/>	<input type="checkbox"/>	
<input type="checkbox"/>	<input type="checkbox"/>	WM-10	Liquid Waste Management	<input type="checkbox"/>	<input type="checkbox"/>	<input type="checkbox"/>	<input type="checkbox"/>	<input type="checkbox"/>	<input type="checkbox"/>	<input type="checkbox"/>	

Describe and attach any photos taken during the inspection, if any:

- 1 \_\_\_\_\_
- 2 \_\_\_\_\_
- 3 \_\_\_\_\_
- 4 \_\_\_\_\_
- 5 \_\_\_\_\_

# Appendix C

## Notice of BMP Noncompliance Form



(Blank Page)





## LOS ANGELES COUNTY DEPARTMENT OF PUBLIC WORKS

### NOTICE OF BMP NONCOMPLIANCE FORM INSTRUCTIONS

- PURPOSE:** To document and monitor a Contractor's non compliance with the proper implementation, effectiveness and maintenance of Best Management Practices (BMPs) on all construction projects.
- PROCEDURE:** When the Contractor has failed to complete the recommended corrective action(s) identified on Construction Site BMP Inspection Checklist, the Inspector shall:
- 1.) Complete this form, including: identify the date of noncompliance, describe the BMP, indicate the location and recommended corrective action(s), and the required completion date for the action(s) (within 2 working days).
  - 2.) The form shall be signed by the Area Supervisor and then a copy shall be given to the Contractor.
  - 3.) Once the recommended corrective actions are completed, the Inspector shall complete and date the corrective actions that were completed.
  - 4.) If the corrective action is not complete by the specified date, the Inspector shall check the "Contractual Sanctions Recommended" column and the Inspector shall immediately notify the ECU.
  - 5.) Contractual Sanctions shall be implemented on a daily basis until the recommended corrective action is completed to the satisfaction of the Inspector and the ECU.
  - 6.) All completed forms shall be reviewed and signed by the Area Supervisor prior to forwarding them to the main office.
- FREQUENCY:** As needed when recommended corrective actions are not completed by required date.
- DISTRIBUTION:**
- 1.) Original form shall be forwarded to the Office Engineer with each week's project records.
  - 2.) The office Engineer shall forward a copy to the ECU.
  - 3.) Copy to be retained by the inspector in the project files.



**LOS ANGELES COUNTY DEPARTMENT OF PUBLIC WORKS**

**NOTICE OF  
BMP NONCOMPLIANCE FORM**

Project Name: _____	PCA No.: _____
Contractor's Name: _____	Project ID No.: _____
LACDPW Staff name: _____	Contractor Rep.: _____
Area Supervisor Approval: _____	Inspection Date/Time: _____
Office Engineer: _____	BMP Checklist Report No: _____

<b>PART 1 Notice of BMP Noncompliance</b>						
No.	BMP Description	Location (Station, Intersection, etc.)	Recommended Corrective Actions (within 2 working days)	Corrections to be Complete By (Date)	Corrective Actions Completed (Date)	Contractual Sanctions Recommended?
1.						<input type="checkbox"/> Yes <input type="checkbox"/> No
2.						<input type="checkbox"/> Yes <input type="checkbox"/> No
3.						<input type="checkbox"/> Yes <input type="checkbox"/> No
4.						<input type="checkbox"/> Yes <input type="checkbox"/> No

**PART 2 (Fill out only when contractual sanctions are recommended) Contractual and Legal Sanctions**

You are advised that failure to comply with or late response to fully implement any of the above required corrective actions for BMP Noncompliance will result in WITHHOLDING OF CONSTRUCTION PROGRESS PAYMENTS of \$1,000.00 per day for each noncompliance described above pursuant to Section 7-8.6 of the contract specifications. Such noncompliance may also be subject to Los Angeles County Code - Section 12.80.630 punishable by a fine of not more than \$1,000 or by imprisonment in the county jail for a period of not to exceed six months, or by both such fine and imprisonment. In addition, any noncompliance may also be subject to the Regional Water Quality Control Board assessment of fines up to \$10,000 per day for each noncompliance and \$10 per gallon of water discharged pursuant to Section 13385 and 13387 of the Porter-Cologne Act.

LACDPW Staff Name: _____	Recipient Name: _____
Title: _____	Title: _____
Telephone No: _____	Telephone No: _____
LACDPW Staff Signature/Date: _____	Signature/Date: _____
Area Supervisor Signature/Date: _____	(Note: Signing this document is not an admission of guilt.)

(See Reverse Side for Instructions)